

## Designed Smart

- Stainless and galvanized steel equipment stands available from 18" to 72" sizes, designed to hold individual or multiple units of Champion Cookline.
- Stainless steel top shelf is designed with a 1 3/4" lip to prevent equipment from sliding off back, front and sides.
- Equipment stands are designed to raise the Champion Cookline to the most convenient cooking heights.
- One inch "bullet feet" are adjustable and convertible to optional casters.
- All tables shipped "knocked down" and are easily assembled.

## Built Solid

### Built to Last

- Heavy duty 16 gauge 304 series stainless steel top
- Heavy duty galvanized steel pipe legs for strength and durability (1 5/8" diameter)
- 5" rubber casters have 200 lbs weight per caster strength (800 lbs per table)

### Reliability backed by APW Wyott's Warranty

- Certified by the following agencies:

**HEAVY-DUTY COOKLINE STAND**

## APW Wyott Design Features

- 304 Series stainless steel top shelf
- Heavy duty galvanized steel legs and bottom shelf
- Bottom shelf is adjustable
- Adjustable legs
- 1 3/4" lip around full perimeter

## Options

- 5" Hard rubber caster Kits (#22800)



See reverse side for product specifications.

Rev. 1/23/2006

PRODUCT:

QUANTITY:

ITEM #:

**PRODUCT SPECIFICATIONS**

**Construction:**

Stainless steel top shelf, galvanized steel bottom shelf, galvanized steel legs.

**Overall Dimensions:**

Model	L	D	H	Weight
SSS-18L	18"	30"	24"	40 lbs
SSS-18C	18"	30"	24"	42 lbs
SSS-24L	24"	30"	24"	48 lbs
SSS-24C	24"	30"	24"	50 lbs
SSS-36L	36"	30"	24"	57 lbs
SSS-36C	36"	30"	24"	59 lbs
SSS-48L	48"	30"	24"	69 lbs
SSS-48C	48"	30"	24"	71 lbs
SSS-60L	60"	30"	24"	78 lbs
SSS-60C	60"	30"	24"	80 lbs
SSS-72L	72"	30"	24"	87 lbs
SSS-72C	72"	30"	24"	89 lbs

**Shipping:**

Freight Class: 70  
FOB Cheyenne, WY 82007

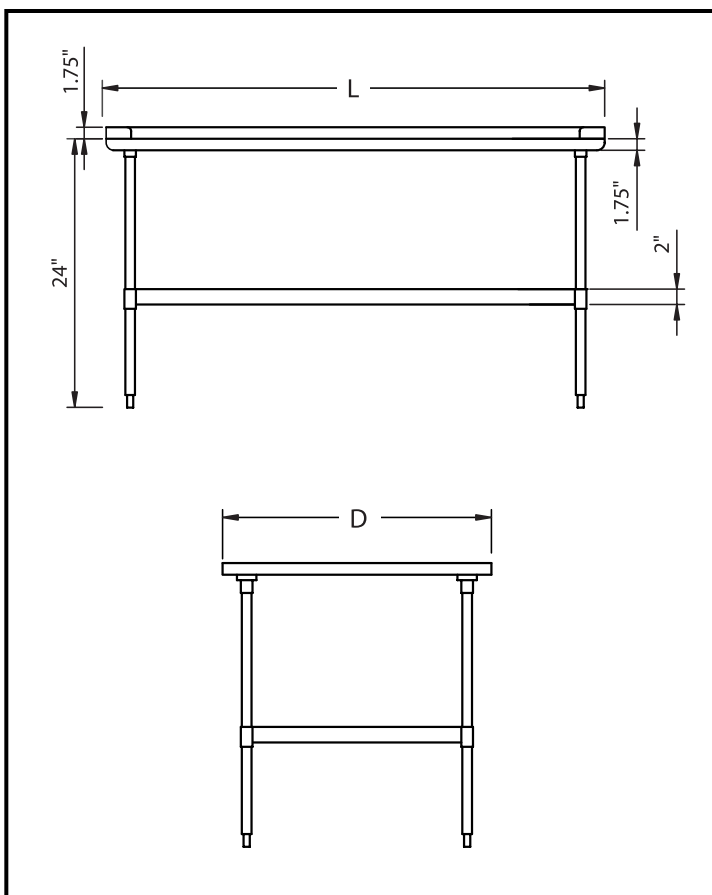

**Consultant Specifications**

Equipment stands are constructed of stainless steel and galvanized steel. Stainless steel top shelf will have 1 3/4" lip around all of the perimeter. Galvanized legs should be 1 7/8" radius. Galvanized bottom shelf will be adjustable. "Bullet legs" will be adjustable. Units are NSF listed.

\*APW Wyott reserves the right to modify specifications or discontinue models without incurring obligation.