

AMERICAN RANGE

Quality Commercial Cooking Equipment

www.americanrange.com

ARSP HEAVY DUTY STOCK POT RANGES

American Range ARSP-series stock pot ranges are design engineered to handle the heaviest loads. Heavy duty construction with stainless steel front and sides, they are both attractive and easy to clean. Heavy duty cast iron 3 ring burners rated at 90,000 BTU per hour, give instant high heat while the dual control valves for the inner and outer rings allow maximum flexibility to maintain desired heat settings. A full width drip tray catches spills and allows the lower cabinet to be used for additional storage. You will find that these rugged units will give many years of trouble free performance.



ARSP

STANDARD FEATURES

- Stainless steel front, and sides.
- Heavy gauge construction
- Cast iron 3-ring burner (90,000 BTU/hr.)
- Standing pilots for instant ignition.
- Dual control valves: One for inner and middle rings. Second for the outer ring.
- Die cast, chrome plated control knobs.
- Full width drip tray to catch spills.
- Lower cabinet storage cavity.

OPTIONS

- Double construction (two units in one cabinet).
- 23 Tip Jet burners rated at 125,000 BTU/hr.
- Under shelf in storage area.
- Swivel casters



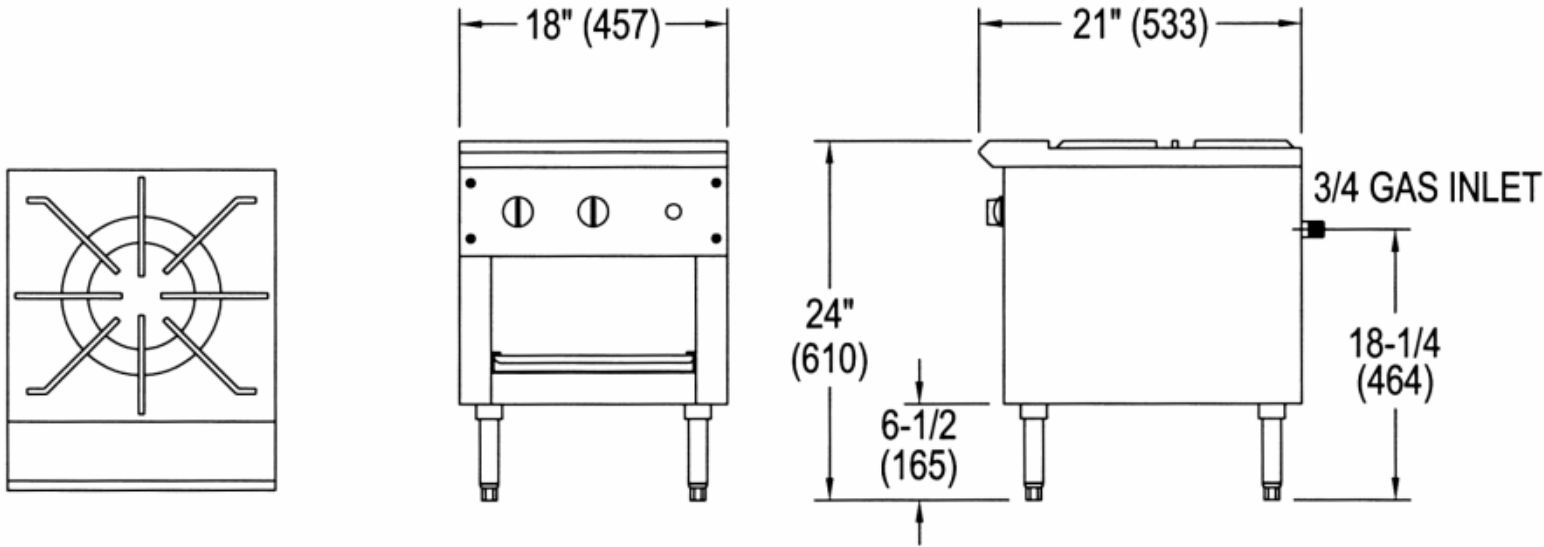

HEAVY DUTY STOCK POT RANGES

MODEL	WIDTH	DEPTH	HEIGHT	BURNERS	TOTAL BTU	KW	SHIP. WT. Lbs.	Kg.
ARSP-18	18"	21"	24"	3-ring	90,000	26.37	130	58
ARSP-18-2	18"	42"	24"	3-ring	180,000	52.75	220	100
ARSP-J	18"	21"	24"	jet	125,000	36.63	110	50
ARSP-J-2	18"	42"	24"	2 jet	250,000	73.25	186	85

STANDARD FEATURES

- Stainless steel front and sides.
- Heavy gauge chassis.
- Heavy duty cast iron top grate.
- Cast iron 3-ring burner (90,000 BTU/hr).
- S/S standing pilots for instant ignition.
 - Dual control valves:
 - One for inner and middle rings.
 - Second for the outer ring.
- Durable die cast, chrome plated control knobs.
- Full width drip tray to catch spills.
- Lower cabinet storage cavity.
- AGA and CGA design certified, NSF Listed.
- One Year Limited Warranty, parts and labor.

OPTIONAL FEATURES

- Double Construction (two units in one cabinet).
- 20 Tip jet burners rated at 125,000 BTU/hr. Standard on ARSP-J
- Swivel casters, set of 4.

Gas: Manifold pressure is 5.0" W.C. for natural gas or 10.0" W.C. for propane gas. Specify type of gas and altitude if over 2000 feet. 3/4" NPT Gas inlet.

Clearances: For use in non combustible locations only, Clearance to non combustible construction 0" sides and back.

American Range Corporation is a quality manufacturer of commercial cooking equipment. Because of continuing product improvements these specifications are subject to change without prior notice.



Pizzaovens.com

1.877.FOR.OVEN
367.6836

Since 1999

