

AMERICAN RANGE

Quality Commercial Cooking Equipment

www.americanrange.com

ARTG

ARTG HEAVY DUTY THERMOSTATIC CONTROL GRIDDLE

American Range ARTG series thermostatic* griddles are design engineered to provide the ultimate in performance and durability. As with all of our heavy duty countertop equipment, they are built to the highest commercial standards to ensure years of trouble free service, featuring superior frame construction and stainless steel exterior for easy maintenance. Combine all of this and our affordable prices and you have the best value for your budget.



ARTG



STANDARD FEATURES

- Stainless Steel Front and Sides.
- Heavy gauge chassis.
- Compact design for counter top use.
- Heavy, highly polished steel griddle plate.
- Available in 3/4" (standard) or 1" (optional) thickness.
- 30,000 BTU/hr steel "U" burners.
- S/S non clog pilots for instant ignition for each burner.
- High quality thermostatic controls (every 2 burners) with a temperature range from 150 to 500 degrees F.
- Optional 4" legs or equipment stand available.
- AGA and CGA design certified, NSF listed.
- One year limited warranty, parts and labor.

*see our ARMG-series for manually controlled griddles.

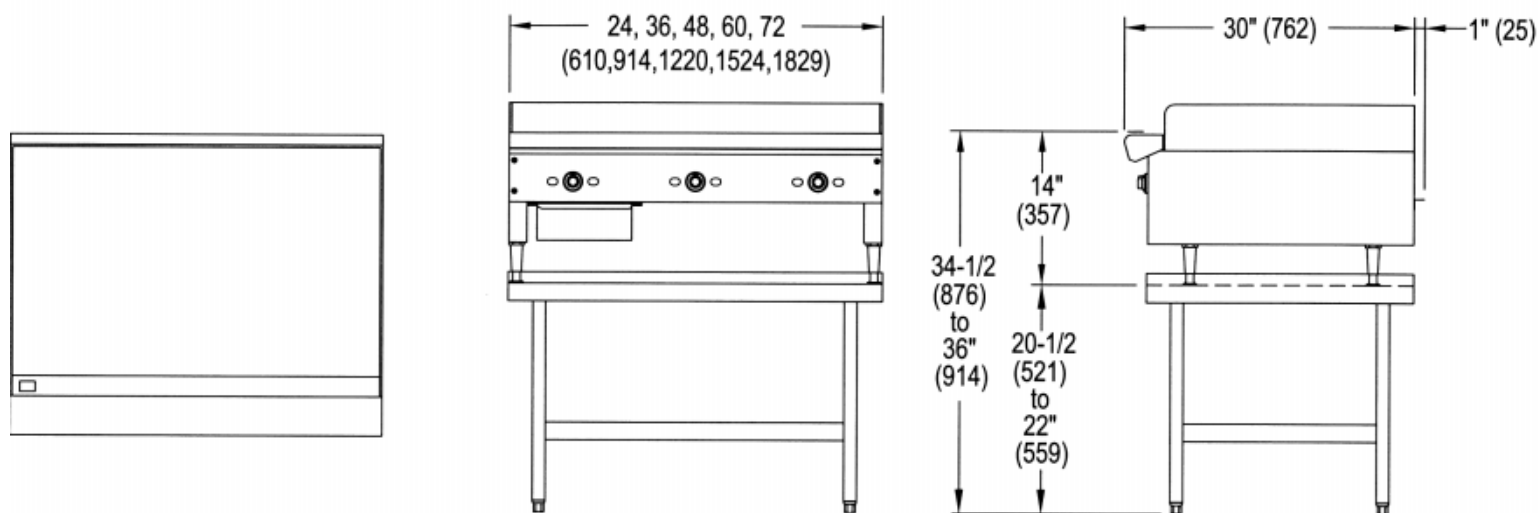

HEAVY DUTY THERMOSTATIC GRIDDLES: Highly polished 3/4" thick plates

MODEL	WIDTH	DEPTH	HEIGHT	BURNERS	# OF T'STATS	TOTAL BTU	KW	SHIP. WT. Lbs.	Kg.
ARTG-24	24"	30"	10"	2	1	60,000	17.58	203	92
ARTG-36	36"	30"	10"	3	2	90,000	26.37	310	140
ARTG-48	48"	30"	10"	4	2	120,000	35.16	365	165
ARTG-60	60"	30"	10"	5	3	150,000	43.96	421	191
ARTG-72	72"	30"	10"	6	3	180,000	52.75	498	225

HEAVY DUTY THERMOSTATIC GRIDDLES WITH: Highly polished 1" thick plates

MODEL	WIDTH	DEPTH	HEIGHT	BURNERS	# OF T'STATS	TOTAL BTU	KW	SHIP. WT. Lbs.	Kg.
ARTG-124	24"	30"	10"	2	1	60,000	17.58	325	147
ARTG-136	36"	30"	10"	3	2	90,000	26.37	435	197
ARTG-148	48"	30"	10"	4	2	120,000	35.16	635	288
ARTG-160	60"	30"	10"	5	3	150,000	43.96	755	342
ARTG-172	72"	30"	10"	6	3	180,000	52.75	895	406

STANDARD FEATURES

THERMOSTATICALLY CONTROLLED GRIDDLES

- Highly polished steel griddle plate, 3/4" (19) thick. (Optional 1" (25.4) thick plate available).
- "U" shape burners, 30,000 BTU/hr. for every 12" (305) of griddle surface.
- Thermostatic controls (for every two burners) with temperature range from 150° -500° F.
- AGA and CGA design certified. NSF listed.
- One year limited warranty, parts and labor.

OPTIONS

- 4" (102) legs adjustable.
- Equipment stand.
- Partial grooving.
- Open burner combinations.
- Saute and wok burner heads (open burner).
- S/S work ring (open burners).
- Easy cleaning, removable cast iron two piece burner heads, allow high gas output of 32,000 BTU, highest in the industry.

Gas: 5.0"W.C.Natural, 10.0"W.C.Propane. Specify type of gas and altitude if over 2000 feet. 3/4" NPT Gas inlet.

Clearances: From non-combustible walls, 0". When unit is placed next to combustible walls, clearances must exceed 12" (305) on sides, and 7" (179) from rear.

American Range Corporation is a quality manufacturer of commercial cooking equipment. Because of continuing product improvements these specifications are subject to change without prior notice.



Pizzaovens.com

1.877.FOR.OVEN
367.6836

Since 1999

