



Restaurant Equipment Worldwide
Toll Free: 877.FOR.OVEN
International: +1 859.885.1988



ANVIL

SLICER

START SERIES CHEESE SLICER • BELT DRIVEN • 12"

SLICER 12" START MANUAL



"Anvil's Start Heavy Duty Cheese slicer offers total quality, safety and hygiene. It is ideal for the cutting of cheese. It can be used continuously."

APPLICATION

- THIS SLICERS GAUGE PLATE, BLADE AND BLADE COVER ARE TEFLON COATED MAKING IT IDEAL FOR CUTTING CHEESE IN CONSISTANT SLICES WITH MINIMAL WASTE AND STRAIN ON THE MOTOR
- IT IS SUITABLE FOR MEDIUM SIZE OPERATIONS IN SUPERMARKETS, DELIS, SUB SHOPS ETC.
- IT CAN ALSO USED FOR CUTTING MEAT AND VEGETABLES IF REQUIRED
- SUITABLE FOR CONTINUOUS USE
- THIS SLICER IS NOT SUITED FOR RAW OR FROZEN MEAT

CONSTRUCTION

- BUILT OF TOP QUALITY ALUMINIUM
- SAFETY AND HYGIENE MEET THE NEEDS OF DEMANDING CUSTOMERS WORLDWIDE
- COMES STANDARD WITH BUILT-IN SHARPENERS AND FIRE PROOF BOTTOM PLATES
- GAUGE PLATE, BLADE AND BLADE COVER ARE TEFLON COATED

Anvil reserves the right, without notice, to make changes and revisions to product specifications, materials and design, which in our opinion, will provide better performance, durability and efficiency.



ALL ANVIL EQUIPMENT COMES WITH A ONE YEAR WARRANTY ON COMPONENTS AND DEFECTIVE WORKMANSHIP

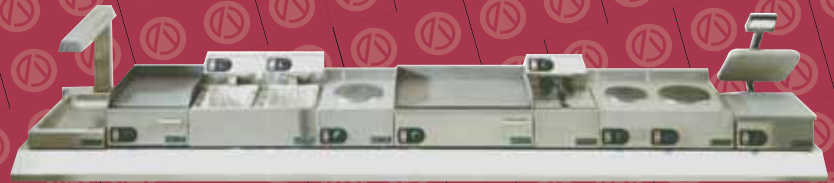

NOTE:

When viewing the appliance from the front in its usual operating position, the width (W) of the product is the total distance from left to right ; the depth (D) of the product is the total distance from front to back ; the height (H) is the total distance from the bottom of the product to the top

SLICER 12" START MANUAL MODELS: SLR7412

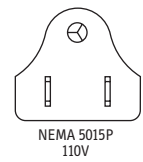
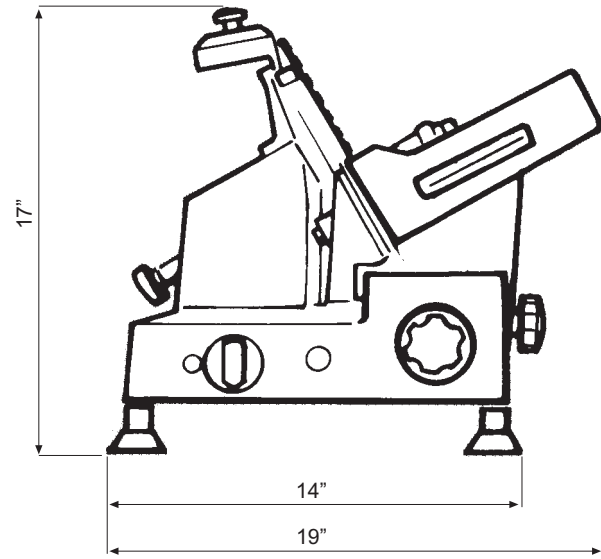
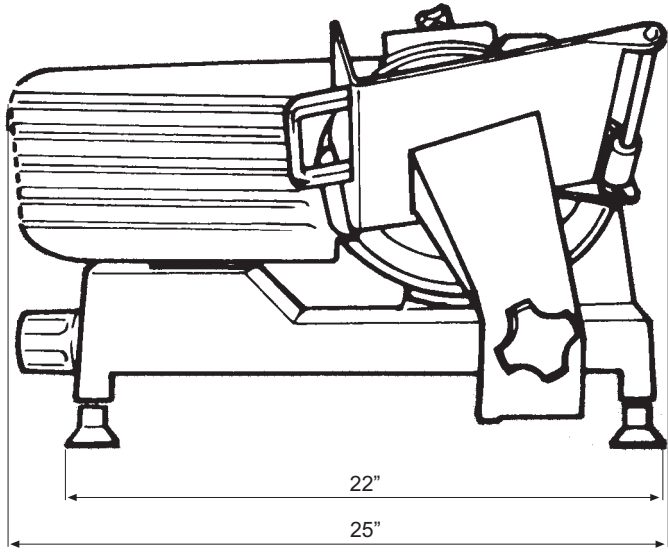

DESCRIPTION	SLICER START 12" TEFLON BLADE
MODELS	SLR7412
CUT CAPACITY (in)	12 ¹ / ₂ x 8 ¹ / ₂
MAX CUT THICKNESS (in)	7/8
BLADE DIAMETER (in)	12
VOLTAGE (V)	110
POWER (HP)	0.5
DIMENSIONS (in) (W x D x H)	19 x 25 x 17
BOX DIMNS (in) (W x D x H)	23 x 28 x 21

Note: Output performance figures quoted are dependant on various factors.

