



Pizzaovens.com

Your Complete Source
for buying the right equipment



ANVIL

MIXER ELECTRIC

PREMIER SERIES - GEAR TRANSMISSION - 30 QUART



MIXER ELECTRIC 30 QUART

"Anvil's 30 Quart Mixer is designed specifically for heavy duty mixing applications. The grease packed ball bearing and air cooled motor ensure quiet and efficient continuous operation."

APPLICATION

- IDEAL FOR CONVENIENCE STORES, BAKERIES AND SUPERMARKETS
- COMES STANDARD WITH MIXING BOWL, WIRE WHISK, DOUGH HOOK AND SPATULA. THESE ITEMS ARE ALSO AVAILABLE SEPERATELY

CONSTRUCTION

- HEAVY DUTY CONSTRUCTION
- POWERFUL 1HP AIR COOLED MOTOR
- 3 FIXED SPEEDS WITH EASY SPEED SHIFTING
- LONG-LIFE GEAR BOX DRIVEN BY COGGED BELT
- #12 HUB FOR A MEAT GRINDING ATTACHMENT OFFERS FLEXIBILITY BETWEEN GRINDING AND MIXING
- GREASE PACKED BALL BEARING
- COMES STANDARD 110V SINGLE PHASE
- COMES STANDARD WITH SAFETY GUARD

Anvil reserves the right, without notice, to make changes and revisions to product specifications, materials and design, which in our opinion, will provide better performance, durability and efficiency.



ALL ANVIL EQUIPMENT COMES WITH A ONE YEAR WARRANTY ON COMPONENTS AND DEFECTIVE WORKMANSHIP

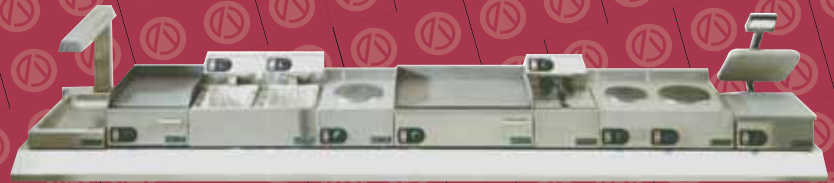

NOTE:

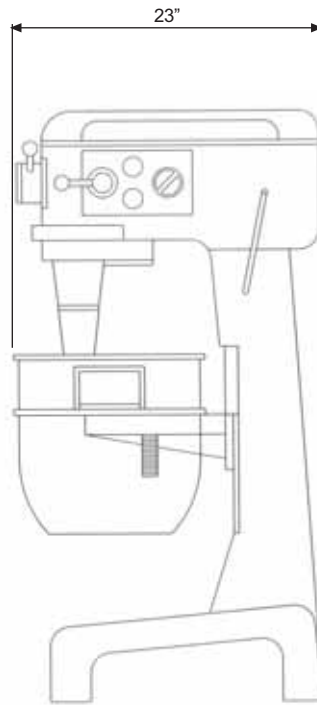
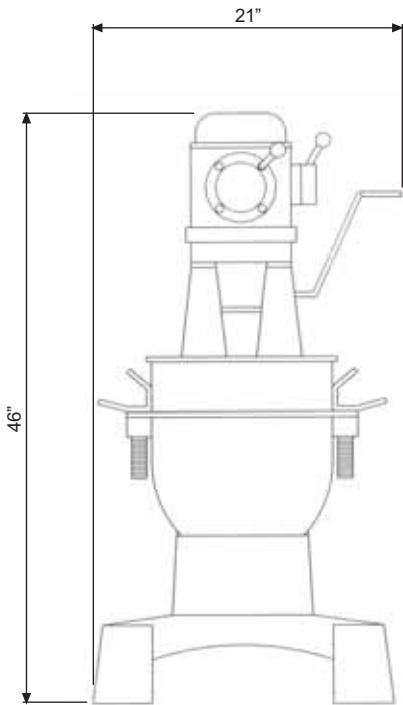

When viewing the appliance from the front in its usual operating position, the width (W) of the product is the total distance from left to right ; the depth (D) of the product is the total distance from front to back ; the height (H) is the total distance from the bottom of the product to the top

MIXER ELECTRIC
30 QUART **MODELS:**
MIX9130

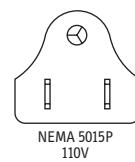

-  MIXING BOWL
XMIX3011
-  WIRE WHISK
XMIX3012
-  DOUGH HOOK
XMIX3013
-  SPATULA
XMIX3014



DESCRIPTION	MIXER 30Q	ACCESSORIES • CODE	ACCESSORIES • DESCR.
MODELS	MIX9130	XMIX3011	MIXING BOWL
POWER (HP)	1	XMIX3012	WIRE WHISK
VOLTAGE (V)	110V	XMIX3013	DOUGH HOOK
DIMENSIONS (in) (W x D x H)	21 x 23 x 46	XMIX3014	SPATULA
BOX DIMNS (in) (W x D x H)	24 x 27 x 51	MIX2016	MEAT GRINDER HEAD NO.12
SHIPPING WEIGHT (lbs)	330	MIX2015	GRATER HEAD NO.12
PLANETARY SPEED	95/190/350 rpm		
			

Note: Output performance figures quoted are dependant on various factors.

Manufactured by:
Scientific Engineering (Pty) Ltd
South Africa
Website: www.anvilworld.com

