



ANVIL

MIXER ELECTRIC

PREMIER SERIES - GEAR TRANSMISSION - 60 QUART



MIXER ELECTRIC 60 QUART

"Anvil's 60 Quart Mixers are designed specifically for heavy duty mixing applications. The grease packed ball bearing and air cooled motor ensure quiet and efficient continuous operation."

APPLICATION

- IDEAL FOR CONVENIENCE STORES, BAKERIES AND SUPERMARKETS
- COMES STANDARD WITH MIXING BOWL, WIRE WHISK, DOUGH HOOK AND SPATULA. THESE ITEMS ARE ALSO AVAILABLE SEPERATELY

CONSTRUCTION

- HEAVY DUTY CONSTRUCTION
- POWERFUL 3HP AIR COOLED MOTOR
- 3 FIXED SPEEDS WITH EASY SPEED SHIFTING
- LONG-LIFE GEAR BOX DRIVEN BY COGGED BELT
- #12 HUB FOR A MEAT GRINDING ATTACHMENT OFFERS FLEXIBILITY BETWEEN GRINDING AND MIXING
- GREASE PACKED BALL BEARING
- COMES STANDARD 220V SINGLE PHASE
- COMES STANDARD WITH SAFETY GUARD

NB: ALL ELECTRICAL CONNECTIONS SHOULD BE CARRIED OUT BY A QUALIFIED TECHNICIAN

Anvil reserves the right, without notice, to make changes and revisions to product specifications, materials and design, which in our opinion, will provide better performance, durability and efficiency.



ALL ANVIL EQUIPMENT COMES WITH A ONE YEAR WARRANTY ON COMPONENTS AND DEFECTIVE WORKMANSHIP

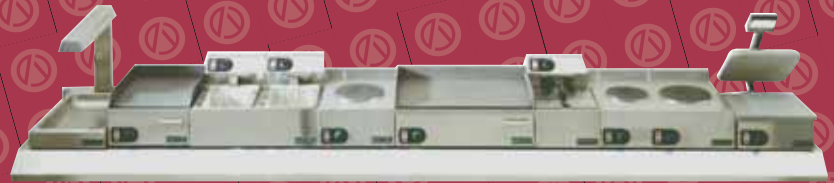

NOTE:

When viewing the appliance from the front in its usual operating position, the width (W) of the product is the total distance from left to right ; the depth (D) of the product is the total distance from front to back ; the height (H) is the total distance from the bottom of the product to the top

**MIXER ELECTRIC
60 QUART** **MODELS:
MIX9160**

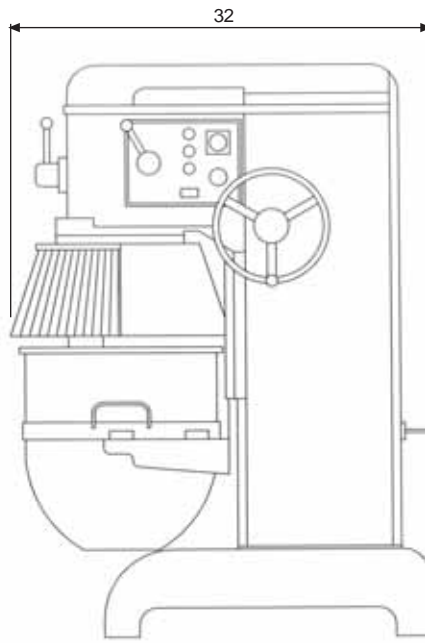
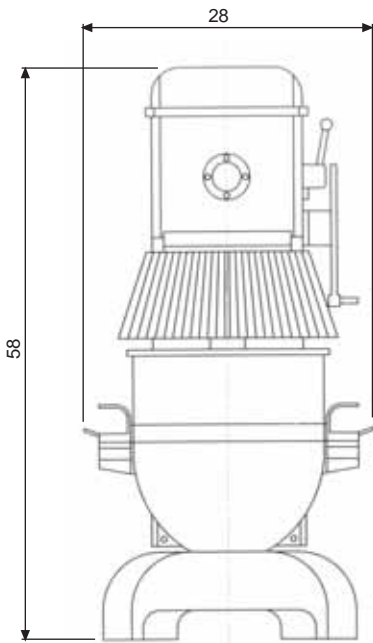

MIXING BOWL
XMIX6011



WIRE WHISK
XMIX6012



DOUGH HOOK
XMIX6013



SPATULA
XMIX6014

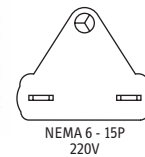

DESCRIPTION	MIXER 60Q	ACCESSORIES • CODE	ACCESSORIES • DESCR.
MODELS	MIX9160	XMIX6011	MIXING BOWL
POWER (HP)	3	XMIX6012	WIRE WHISK
VOLTAGE (V)	220V SINGLE PHASE	XMIX6013	DOUGH HOOK
DIMENSIONS (in) (W x D x H)	28 x 32 x 58	XMIX6014	SPATULA
BOX DIMNS (in) (W x D x H)	36 x 48 x 66	MIX2016	MEAT GRINDER HEAD NO.12
SHIPPING WEIGHT (lbs)	900	MIX2015	GRATER HEAD NO.12
PLANETARY SPEED	100/177/297/523 rpm		



Pizzaovens.com

For More Information

Call Us Toll Free 877 367 6836



MIX_ANVIL_USA_09