



BKI®

Fresh ideas in foodservice equipment



BKI's LPF-F Electric Pressure Fryer shown above

Agency Approvals:



Pressure Fryers

Model: LPF, LPF-F, LPF-FC

Large Volume Electric Pressure Fryer with optional Computer and Filter

Designed for simple, safe, economical operation, BKI's electric pressure fryers enhance fried food operations and increase food quality. Controlled low pressure-cooking delivers moist, tender fried food with a 30% longer holding capability. Patented "Quick-Connect" filtration system improves operations through a fail-safe alignment feature, while the built-in cold zone collects breading "fall-off" to extend shortening life for a substantial savings. Highest quality construction stands up to heavy use. Exceptional pricing makes the BKI electric pressure fryer the profitable, value choice for any retail or catering business.

Standard Features:

- 14 lbs. (6.4 kg) Product, 48 lbs. (21.8 kg) Oil Capacity (4 Head Chicken)
- Utilizes controlled low pressure
- Pressure regulated lid interlock system
- 3" Casters for easy mobility
- External Material (18 gauge, 304 Stainless Steel)

BKI North America
PO Box 80400
Simpsonville, SC 29680-0400 USA
Telephone: (864) 963-3471
Toll Free: (800) 927-6887

BKI Europe
Theale Technology Centre
Station Road • Theale
Reading • West Berkshire • RG7 4AA
Telephone: 0870 9904242 • Fax: 0870 9904243



Pressure Fryers (LPF, LPF-F, LPF-FC)

Equipment Dimensions:

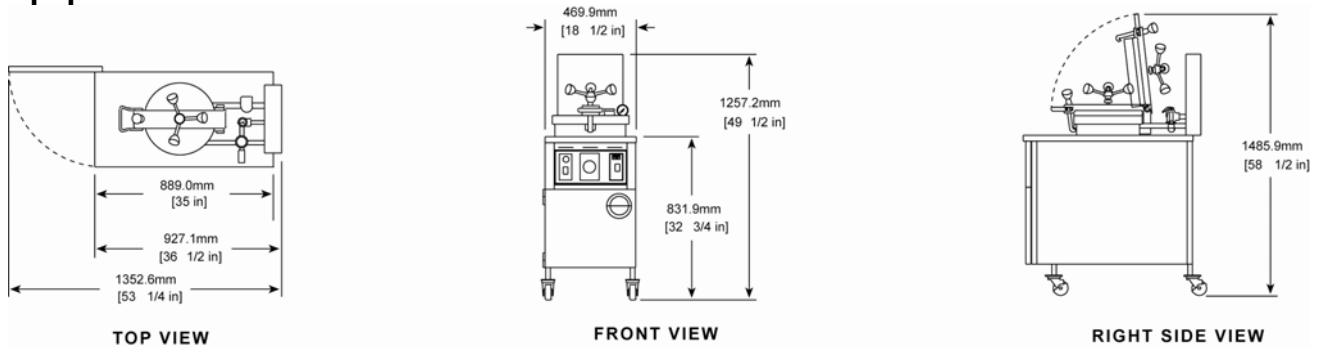

LPF is depicted above but the dimensions shown apply to all models.

Mechanical Specifications:

Dimension	Uncrated	Crated
Height	32.75" (831.9 mm)	58" (1475.8 mm)
Width	18.5" (469.9 mm)	27" (687 mm)
Depth	36.5" (927.1 mm)	42" (1068.7 mm)
Floor Space	4.7 sq. ft (.44 sq. m)	7.9 sq. ft (.73 sq. m)
Weight	300 lb. (136.1 kg)	320 lb. (145.2 kg)

Parameter	Value
Operating PSI	12 psi
Safety Release PSI	15 psi

Electrical Options:

Volts	Amps	Breaker	KW	Wires	Phase
208	37.5	45	13.5	3	3
220/380	17	25	11.3	4	3
240/415	19	30	13.5	4	3
208/60Hz	38/65	70/45	13.5	2/3	1/3
240/60Hz	57/33	65/40	13.5	2/3	1/3
220/50Hz	68.7	80	13.5	2	1
240/50Hz	19	30	13.5	4	3
240/60Hz	32.5	40	13.5	3	3

Accessories (Optional)

	LPF	LPF-F	LPF-FC
Filter Rinse Hose assembly (SB2332)	✓	✓	✓
Filter Vat Dolly (SB8658)		✓	✓
Breading Table (420205) & (420206)	✓	✓	✓
Landing Table with Dump Tray (310600)	✓	✓	✓
Tiered basket with lift handle (AN86205300)	✓	✓	✓
Layered Basket (B0117B)	✓	✓	✓
LPF Basket to be used with lift handle H0151 (B0111B)*	✓	✓	✓
White pot scrubber brush (B0049)*	✓	✓	✓
Long black brush (B0051)*	✓	✓	✓
Short black brush (B0052)*	✓	✓	✓
L-Tipped brush (B0063)*	✓	✓	✓
White drain brush (B0075)*	✓	✓	✓
Lift handle assembly (H0151)*	✓	✓	✓
13" insulating mitts (G0052)*	✓	✓	✓
cordset 7' (SB7655)	✓	✓	✓
Filter Paper (F10007)**		✓	✓

* - Included with each model

** - 5 included with LPF-F and LPF-FC

Model Features

	LPF	LPF-F	LPF-FC
Microprocessor controlled for enhanced cooking capabilities			✓
"Quick-Disconnect" filter system to ensure user safety and proper filter alignment		✓	✓



BKI North America
 PO Box 80400
 Simpsonville, SC 29680-0400 USA
 Telephone: (864) 963-3471
 Toll Free: (800) 927-6887

BKI Europe
 Theale Technology Centre
 Station Road • Theale
 Reading • West Berkshire • RG7 4AA
 Telephone: 0870 9904242 • Fax: 0870 9904243

