

PRESSURE REGULATOR:

Each oven shall be equipped with a gas pressure regulator. Pressure setting shall be 5" water column for natural gas and 10" water column for LP gas (11" in Canada). LP regulator not required in Canada.

BURNER:

Each oven shall be provided with a burner system located to provide even heat distribution throughout the oven compartment. The burner system shall be fully protected and serviceable from the front of the oven.

GAS PIPING:

All piping, connections, controls, etc., shall be located within the oven body and

shall be easily accessible through a covered and ventilated front panel.

STACKING:

When ovens are stacked they shall be stacked evenly with no wasted space in between the top and bottom unit.

WARRANTY:

Each oven shall be covered under limited Warranty, for parts and labor, for a period of one year. See warranty.

APPROVALS:

The unit shall bear the approvals of American Gas Association, Canadian Gas Association and National Sanitation Foundation.

Continuous product improvement is a policy of Bakers Pride Oven Co. Therefore specifications and design are subject to change without notice.

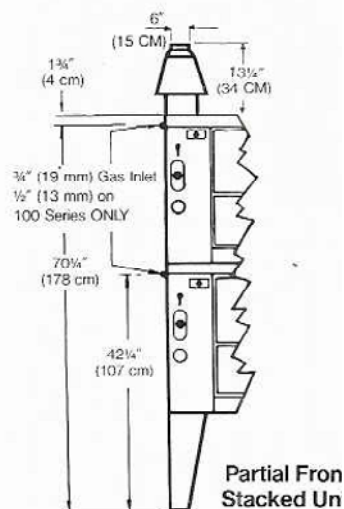
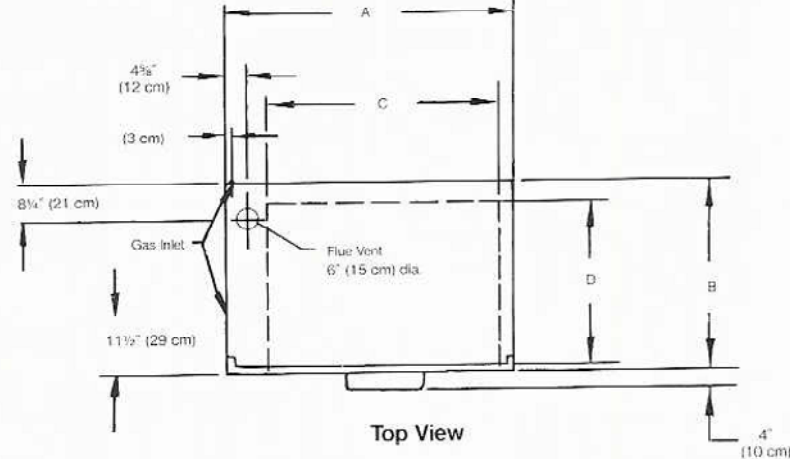
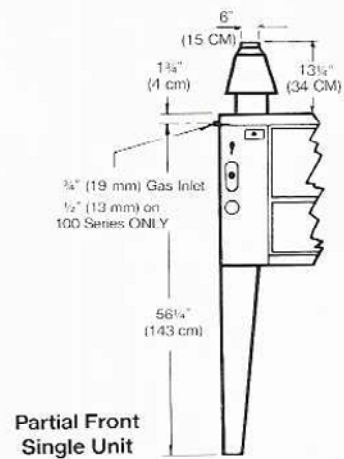
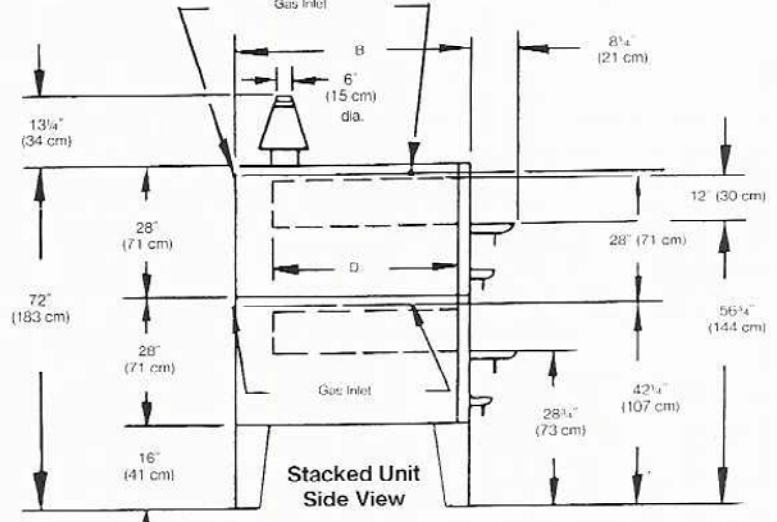
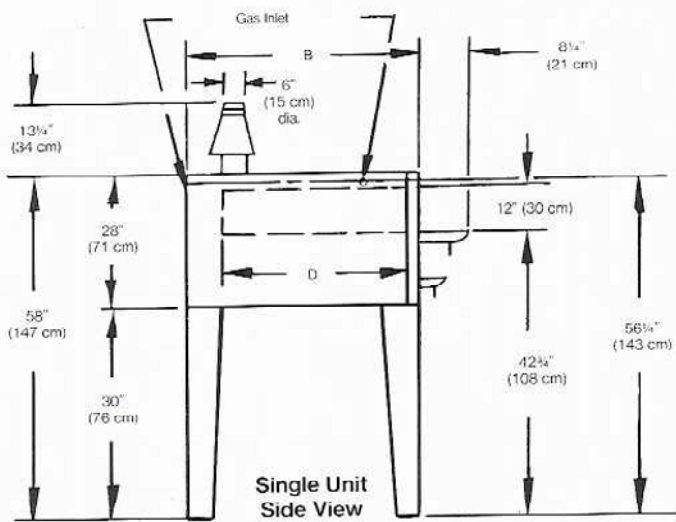

Model	A	B	C	D	# decks	BTU (kilogram calories)	Shipping Wt. (approx.)	Crate Size	Pizza Capacity
104P	48"	33"	36"	24 1/2"	1	48,000 (12,096 kgc)	890 Lbs. (404 kg)	44.0 Cu. Ft. (1.3 Cu. Met.)	(3) 16" (3) 41 cm
105P	(122 cm)	(84 cm)	(91 cm)	(62 cm)	2	96,000 (24,192 kgc)	1744 Lbs. (791 kg)	83.1 Cu. Ft. (2.4 Cu. Met.)	(6) 16" (6) 41 cm
204P	48"	43"	36"	34 1/2"	1	60,000 (15,120 kgc)	1029 Lbs. (467 kg)	54.9 Cu. Ft. (1.6 Cu. Met.)	(4) 16" (4) 41 cm
205P	(122 cm)	(109 cm)	(91 cm)	(88 cm)	2	120,000 (30,240 kgc)	2022 Lbs. (917 kg)	104.9 Cu. Ft. (3.0 Cu. Met.)	(8) 16" (8) 41 cm
304P	57"	43"	45"	34 1/2"	1	70,000 (17,640 kgc)	1185 Lbs. (538 kg)	63.4 Cu. Ft. (1.8 Cu. Met.)	(4) 16" (4) 41 cm
305P	(145 cm)	(109 cm)	(114 cm)	(88 cm)	2	140,000 (35,280 kgc)	2334 Lbs. (1059 kg)	121.9 Cu. Ft. (3.5 Cu. Met.)	(8) 16" (8) 41 cm
404P	66"	43"	54"	34 1/2"	1	80,000 (20,160 kgc)	1372 Lbs. (622 kg)	71.7 Co. Ft. (2.0 Cu. Met.)	(6) 16" (6) 41 cm
405P	(168 cm)	(109 cm)	(137 cm)	(88 cm)	2	160,000 (40,320 kgc)	2708 Lbs. (1228 kg)	138.5 Cu. Ft. (3.9 Cu. Met.)	(12) 16" (12) 41 cm