



SUPER DECK D SERIES GAS DECK OVENS



Model D-125
with optional casters

SPECIFICATIONS

BAKERS PRIDE Super Deck D Series gas Deck Ovens are designed for high volume pizza, baking and all-purpose operations.

Ovens may be stacked two high. Oven exteriors are all heavy-gauge, type 403 stainless steel and are fully insulated up to 5" (127mm) thick for cooler outer temperatures and consistent interior temperatures.

Interior oven frame is constructed of 1/4" (6mm) heavy-duty angle iron frame, completely welded to form a single, unitized section. The oven body and lining are then welded to the framework.

Oven interiors are manufactured of high-heat resistant 16-gauge aluminized steel. Doors are fully insulated, spring balanced with tubular steel handles and will remain open or closed until moved.

All models feature independent, operator-controlled top & bottom heat control dampers and micro slides for perfectly balanced results.

D Series features a 300°-650° F (149°-343°C) throttling thermostat, 10" (254mm) interior deck height with 1 1/2" (38mm) thick Cordierite hearth decks (steel decks optional) and are supported by a 1/4" (6mm) angle iron frame.

Combination gas control incorporates a manual gas valve, safety pilot and pressure regulator. Easily removable, slide-out, heavy-duty flame diverters distribute the burner flame uniformly in the burner chamber. A 3/4" (19mm) NPT gas connection is located on the left side and left rear of oven - operator/installer may choose.

Heavy-duty, 7-gauge hot rolled steel legs are standard and finished with durable Bakertone gray paint.

1 Year limited part and labor warranty standard.

Job _____ Item # _____

GAS DECK OVENS



- Model D-125 Single
- Model D-250 Double

STANDARD FEATURES

- D Series @ 125,000 BTUH per deck natural gas or 105,000 BTUH in LP gas
- 300°-650° F (149°-343°C) throttling thermostat
- Top & bottom heat control dampers & micro-slides
- Combination gas controls with valve, regulator & safety pilot
- Heavy-duty, slide-out flame diverters
- 10" (254mm) interior deck heights with 1 1/2" (38mm) thick Cordierite hearth decks
- All stainless steel exteriors
- Aluminized steel interiors
- Spring balanced, fully insulated doors
- Left side or rear gas connections
- 7-Gauge legs
- Fully insulated throughout
- 1 Year limited part and labor warranty

OPTIONS & ACCESSORIES

- Steel decks
- 150°-550° F (65°-288°C) bake thermostat
- 350°-700° F (149°-371°C) high-heat thermostat
- Set of 4 casters - two with locks
- Stainless steel leg covers
- Special height legs
- Automatic oven starter
- Draft flue for direct vent (not available on CE units)

CERTIFICATIONS



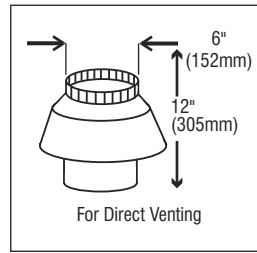
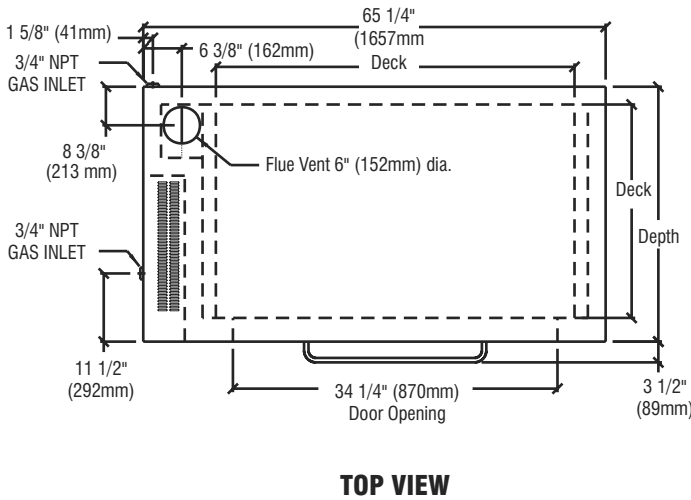
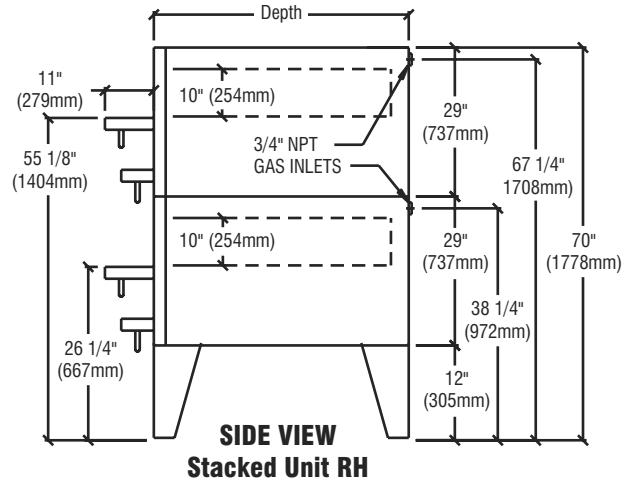
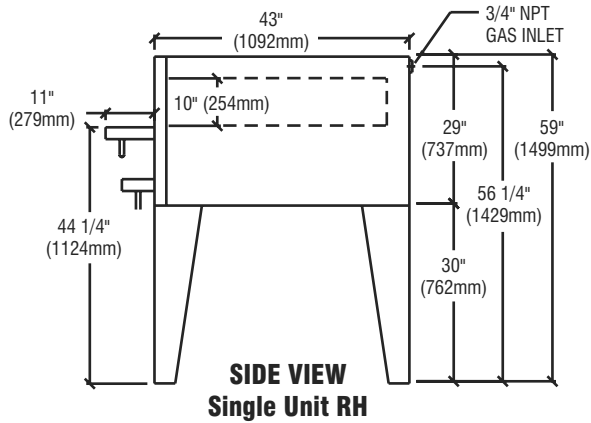

MUST BE SPECIFIED AT TIME OF ORDER

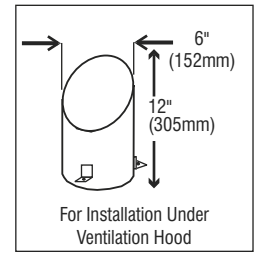

STANDARD

ALL DIMENSIONS NOMINAL

Model	Shipping Weight		Carton Dimensions				Crate Size			
	Lbs.	Kilos	Width Inches	Width mm	Depth Inches	Depth mm	Height Inches	Height mm	Cubic Feet	Cubic Meter
D-125	1385	626	31	787	53	1364	82	2083	88	2.5

Each oven ships separately
Hearth Decks and Legs ship in separate cartons

GAS SUPPLY				
Model	GAS TYPE	BTUR	KW	CONNECTION
D-125	natural	125,000	36.6	3/4"
D-250	natural	250,000	30.7	3/4"
D-125	LP	105,000	73.2	3/4"
D-250	LP	210,000	61.4	3/4"

CE certification not available in LP gas

Model	Deck Sizes		# Decks	Overall Dimensions					
	in.	mm		Width Inches	Width mm	Depth Inches	Depth mm	Height Inches	Height mm
D-125	48 x 36	1219 x 914	1	65 1/4	1657	43	1092	59	1499
D-250	48 x 36	1219 x 914	2	65 1/4	1657	43	1092	70	1778

	MINIMUM CLEARANCES			
	Noncombustible Construction		Combustible Construction	
	Inches	mm	Inches	mm
Right	0	0	1	25
Left	0	0	3	76
Rear	2	51	3	76



Pizzaovens.com

Your Complete Source for buying the right equipment