



HEARTHBAKE GP SERIES GAS COUNTER TOP OVENS

Job _____ Item # _____

GAS COUNTER TOP OVENS



Model GP-61

- Model GP-51 Single
- Model GP-52 Double
- Model GP-61 Single Model GP-61HP Single
- Model GP-62 Double Model GP-62HP Double

STANDARD FEATURES

- 40,000 BTUH per oven model GP-51 and 45,000 BTUH per oven model GP-61 - 60,000 BTUH available on GP-61HP
- Stackable for double production capacity
- Natural or propane gas
- Energy efficient ,modulating thermostat and combination gas control valve
- Unique heat flow system for optimum flexibility
- Standard 300° F (149°C) to 650° F (343°C) temperature range
- Two bake chambers per oven with 1" thick Cordierite ceramic hearth bake decks
- Two independent stainless steel, bottom hinged doors with field reversible handles for left or right hand operation
- 4" adjustable chrome plated legs
- All stainless steel exterior
- Stainless steel combustion chamber
- Aluminized steel bake chambers
- Slide-out flame diverter
- Front mounted, hinged control-valve access panel
- Heavy-duty industrial grade insulation in top, sides, back, bottom and doors

SPECIFICATIONS

Natural or LP gas heated counter top ovens. Standard specifications include two bake chambers each with 1" thick Cordierite ceramic hearth decks with independent bottom hinged doors, reversible side mounted handles, 40,000 to 60,000 BTUH per oven, 3/4" NPT (ISO7) rear gas connection, and unique heat flow system that optimizes top and bottom heat. Bottom deck is best for rapid baking while the upper deck is for slower baking.

Modulating thermostat saves energy and assures balanced heat. Standard thermostat has a temperature range up to 650° F (343°C) and is ideal for pizza while a no charge optional 550° F (287° C) thermostat is ideal for baking and roasting. A standard combination valve incorporates a manual gas valve, pilot safety and gas regulator.

The oven exterior is constructed of durable stainless steel. Model GP-51 measures 32 5/8" wide (829mm) and model GP-61 measures 41 5/8" wide (1,057mm). Both models measure 31 1/4" deep (794mm) by 25 1/8" high (638mm) and may be double stacked. 4" (102mm) adjustable chrome plated legs are standard.

The combustion chamber is constructed of 18 gauge type 304 stainless steel and features easily removable slide out flame diverter. The baking chamber is heavy gauge high heat aluminized steel. Interior bake chambers are 26 1/4" (667mm) deep and will each accommodate a full size sheet pan lengthwise. Bake chamber heights are 6" (152mm) on the lower deck and 5" (127mm) on the upper deck.

OPTIONS & ACCESSORIES

- 60,000 BTUH on GP-61 / 12,000 BTUH on GP-62
- Single door in lieu of double doors
- Removable upper deck on single door unit for 12" (308mm) bake and roast chamber height
- Bake and roast thermostat with 150 F (65 C) to 550 F (288 C) temperature range
- Automatic oven starter
- Draft hood for direct venting
- 16" (406mm) legs in stainless or Baker tone for stacked units
- 30" (762mm) legs in stainless or Baker tone for floor use
- Stainless steel under shelf for use with 30" (762mm) legs
- Heavy-duty caster set, two with locks, for use with 16" (406mm) or 30" (762mm) legs
- 48" (1219mm) quick-disconnect gas hose with or without restraining cable

CERTIFICATIONS



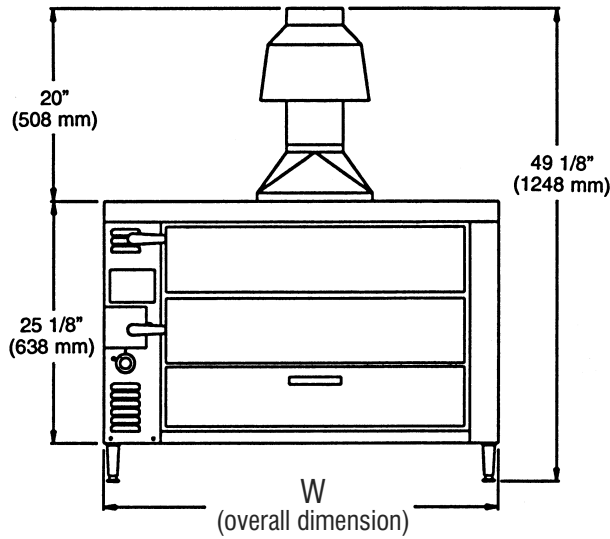

FRONT VIEW

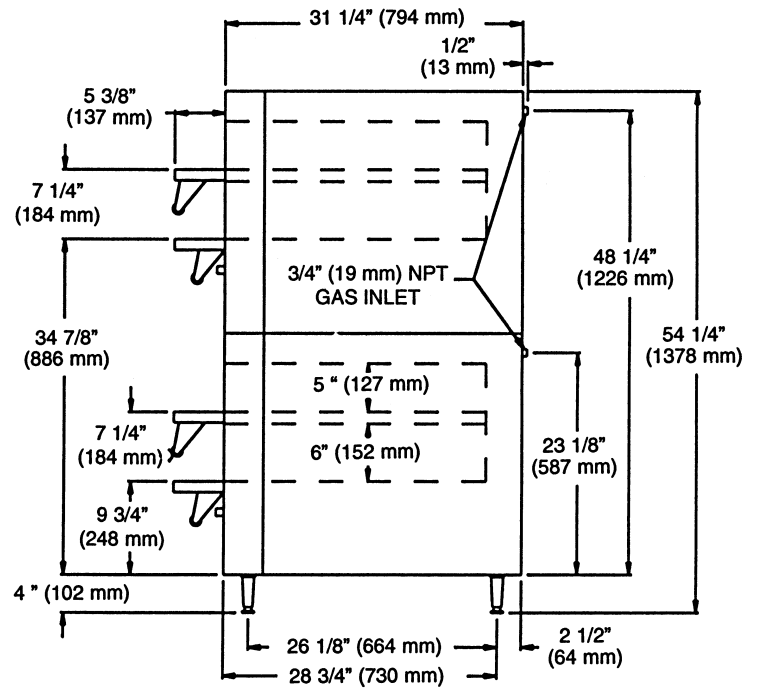

STACKED UNIT SIDE VIEW

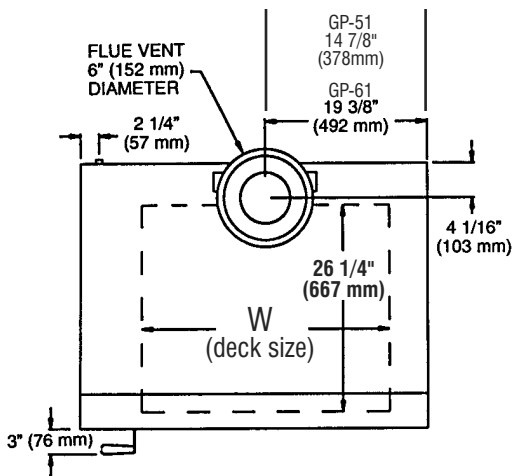

TOP VIEW

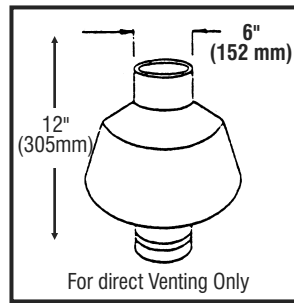

MUST BE SPECIFIED AT TIME OF ORDER

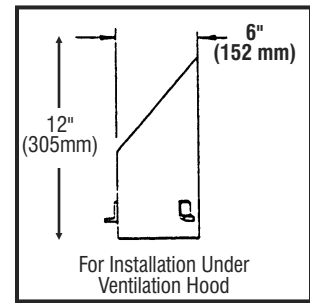

STANDARD

SHIPPING INFORMATION

Model	Shipping Weight		Carton Dimensions				Crate Size			
	Lbs.	Kilos	Width Inches	mm	Depth Inches	mm	Height Inches	mm	Cubic Feet	Cubic Meter
GP-51	405	205	52	1321	39	991	36	915	43.8	1.2
GP-52	shipped in two GP-51 cartons									
GP-61	525	483	52	1321	39	991	36	915	43.8	1.2
GP-62	shipped in two GP-61 cartons									

Shipping Class # 70

GAS SUPPLY — 3/4" NPT gas connection

Model	BTUH	KW
GP-51	40,000	11.72
GP-52	80,000	23.44
GP-61	45,000	13.19
GP-62	90,000	26.37
GP-61HP	60,000	17.58
GP-62HP	120,000	35.16

CE certification not available in LP gas. Each oven requires separate gas connection.

SPECIFICATIONS

Model	Deck Size		# of Decks	# Cooking Chambers	Overall Dimensions*					
	in.	mm			Width Inches	mm	Depth Inches	mm	Height* Inches	mm
GP-51	20 5/8x26 1/4	524x667	2	2	32 5/8	829	31 1/4	794	29 1/8	740
GP-52	20 5/8x26 1/4	524x667	4	4	32 5/8	829	31 1/4	794	54 1/4	1378
GP-61	29 5/8x26 1/4	752x667	2	2	41 5/8	1057	31 1/4	794	29 1/8	740
GP-62	29 5/8x26 1/4	752x667	4	4	41 5/8	1057	31 1/4	794	54 1/4	1378

NOTE: GP61 / 62 HP same dimensions as standard GP-61 / 62

*Height includes 4" (102 mm) standard legs

MINIMUM CLEARANCES

	Combustible Construction		Non-Combustible Construction	
	Inches	mm	Inches	mm
Right	2	51	2	51
Left	1	25	0	0
Rear	5	127	2	51

* From non-combustible construction

