



## COUNTER TOP ELECTRIC OVENS



Pizzaovens.com

1.877.FOR.OVEN  
367.6836

Since 1999

- Model PX-14
- Model PX-16



Model PX-16

### SPECIFICATIONS

The PX Series all purpose electric counter top ovens are designed for baking, warming and finishing and are ideal for applications ranging from par baked products to sushi.

Standard features include an all stainless steel exterior, slide-out, nickel-chrome plated wire baking rack with heat resistant handle, pull-out steel crumb tray and 3" (76mm) deck height.

Controls feature independently, operator controlled top and bottom heat for perfectly balanced baking results, a 284°-680°F (140°-360°C) and a 15 minute electric timer with continuous ring alarm and manual shut-off.

The exterior is fabricated of heavy gauge type 430 stainless steel with a #4 finish. Legs are black phenolic. The PX-14 measures 19 5/8" (240mm) wide by 16 1/2" (419mm) deep by 9 7/8" (251mm) high overall.

The PX-16 measures 24" (610mm) wide by 20 1/2" (521mm) deep by 9 7/16" (251mm) high overall.

The interiors are constructed of heat tolerant aluminized steel, welded to form a single unitized body. The entire oven is insulated with 1" (25.4mm) thick industrial grade felt. The PX-14 baking rack measures 13 1/4" (337mm) wide by 13 7/8" (352mm) deep while the PX-16 baking rack measures 17 5/8" (448mm) by 17 7/8" (454mm) deep.

Two independently controlled incloy-heating elements provide top and bottom heat with up to 1500 watts for the PX-14 and up to 1800 watts for the PX-16. Available in 120v or 208-240v, single phase. 6' Cord and plug provided in standard voltages. International voltages available. Ovens are stackable. 1-Year limited parts and labor warranty included.

### STANDARD FEATURES

- PX-14 @ 1500 watts
- PX-16 @ 1800 watts
- 284°-680°F (140°-360°C) Temperature range
- Electric 15 minute timer with continuous ring alarm and manual shut off
- Independent, operator controlled top and bottom heat
- 3" (76mm) Deck height
- Slide-out, heavy gauge, nickel-chrome plated wire baking rack with handle
- Pull out steel crumb tray
- All stainless steel exterior
- Black phenolic legs
- Unitized, welded, aluminized steel interior
- Fully insulated
- 6' (1830mm) Cord & plug
- Limited 1-Year parts and labor warranty

### OPTIONS & ACCESSORIES

### CERTIFICATIONS



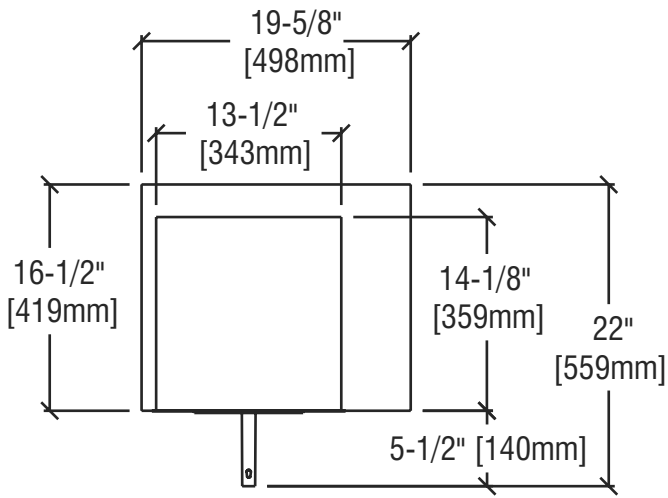

**TOP VIEW PX-14**

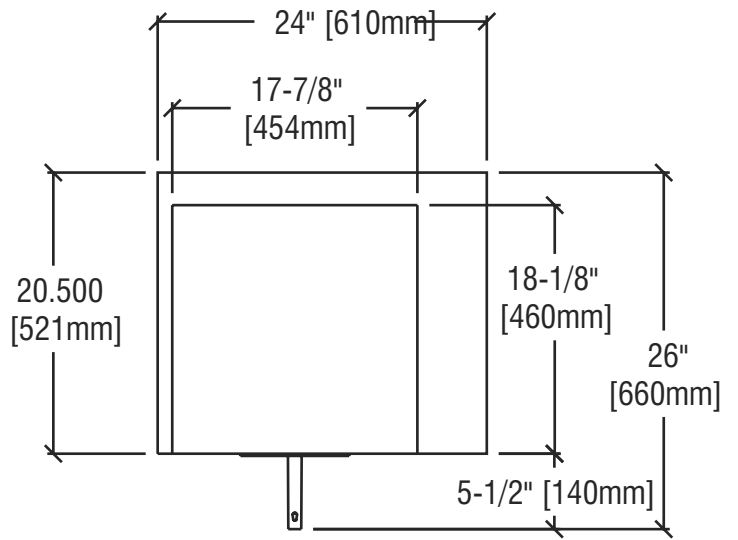

**TOP VIEW PX-16**

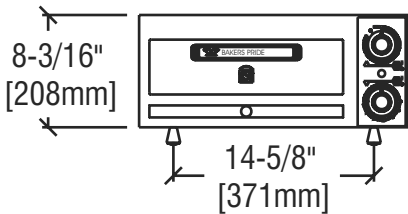

**FRONT VIEW PX-14**

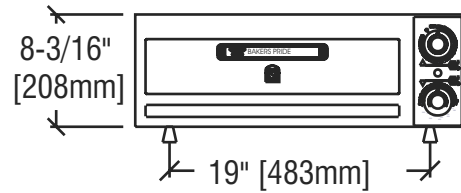

**FRONT VIEW PX-16**

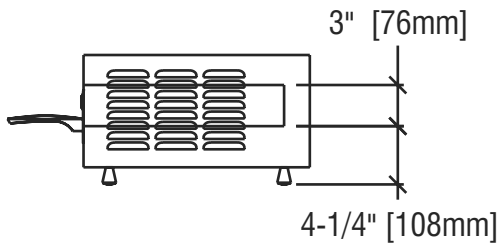

**RH SIDE VIEW PX-14**

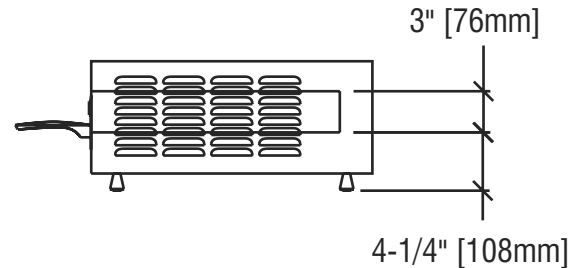

**RH SIDE VIEW PX-16**

ALL DIMENSIONS NOMINAL

Model	Shipping Weight		Carton Dimensions				Crate Size			
	Lbs.	Kilos	Width Inches	mm	Depth Inches	mm	Height Inches	mm	Cubic Feet	Cubic Meter
PX-14	49	22	24	610	22	559	12	305	3.7	.11
PX-16	69	31	30	762	26	660	12	305	5.4	.16

Under 500 lbs = Shipping Class # 70

Model	WATTS	VOLTAGE	PHASE	AMPS	Plug #			
					USA	Canada	UK	Europe
PX-14	1500	120	1	12.5	5-15P	5-20P	—	—
	1500	208-240	1	8.1	6-15P	6-15P	BS1363A	CEE7-VII
PX-16	1800	120	1	15.0	5-15P	5-15P	—	—
	1800	208-240	1	8.7	6-15P	6-15P	BS1363A	CEE7-VII

Each oven requires a separate electrical connection — 3 Phase and Export Voltages No Line Cord

Model	Rack Size		# Decks	# Cook Chambers	Overall Dimensions					
	Inches	mm			Width Inches	mm	Depth Inches	mm	Height* Inches	mm
PX-14	13 1/4x13 7/8	337x352	1	1	19 1/2	495	16 1/2	419	9 7/16	251
PX-16	17 5/8x17 5/8	448x454	1	1	24	610	20 1/2	521	9 7/8	251



5-15P



6-15P



5-20P



BS 1363 A



CEE 7-VII

**MINIMUM CLEARANCES**

	Non-Combustible Construction*		Combustible Construction**	
	Inches	mm	Inches	mm
Left Side	3	76	3	76
Right Side	3	76	3	76
Rear	3	76	3	76

\* In European Community Countries and North America. In NON-COMBUSTIBLE locations only.  
\*\* In European Community Countries only in COMBUSTIBLE locations. NOT for North America.



**Pizzaovens.com**

1.877.FOR.OVEN  
367.6836

Since 1999