



MODEL 966 Deck Oven



Project _____

Item No. _____

Quantity _____

Ovens consist of basic sections and are a complete and separate unit capable of operating alone or in combination.

All data is shown per oven section, unless otherwise indicated.

Refer to operator manual specification chart for listed model name.

966 - Single/Double

EXTERIOR CONSTRUCTION

- Full angle iron frame
- Stainless steel front, top, sides and back
- Counterbalanced doors with concealed hinges
- Heavy chrome plated tubular steel door handle
- 19" (483mm) black powder coated legs (for single units)
- 7" (178mm) black powder coated legs (for double units)
- Burner doors open easily for ignition, cleaning or adjustment, without removal of any fastenings
- Vitreous fiber insulation at top, back, sides, bottom and doors

INTERIOR CONSTRUCTION

- 42" x 32" x 16-1/4" (1067mm x 813mm x 1413mm) oven compartment interior
- Aluminized steel baking compartment liner
- Aluminized steel combustion chamber
- Steel deck supported by an angle iron frame
- 12 gauge (3.02mm) press-formed, reinforced and flanged aluminized steel deck

OPERATION

- Free-floating, easily removable duplex-tube burner
- Removable fixed orifices on main and pilot burner
- Main gas valve, temperature control valve and safety pilot valve fully within section body and are accessible through a covered and ventilated compartment in front.
- Air mixers with adjustable air shutters and locking device
- Liquid pressure thermostat with temperature control range of 200°F (93°C) to 500°F (288°C)

STANDARD FEATURES

- Steel oven deck
- Fahrenheit dial 200°F to 500°F
- Two year oven parts and one year labor warranty*
- Five year limited oven door warranty*

* For all international markets, contact your local distributor.



OPTIONS AND ACCESSORIES

(AT ADDITIONAL CHARGE)

- **Stainless steel legs**
 - 7" (178mm) stainless steel legs
 - 19" (483mm) stainless steel legs
- **Flexible gas hose with quick disconnect and restraining device:**
 - 36" (914 mm)
 - 48" (1219mm)
- Casters
- Stainless steel crown angle trim
- Vent kit
- Double connector for stacking
- Ultra Rokite shelves, 1-1/2" (38.1mm) thick (pizza type shelf)
- Steam jets

OPTIONS AND ACCESSORIES

(AT NO ADDITIONAL CHARGE)

- FDTH 300° to 650° temperature thermostat
- Centigrade dial, 100°C to 300°C





MODEL 966

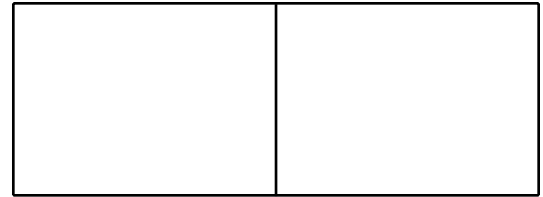

APPROVAL/STAMP

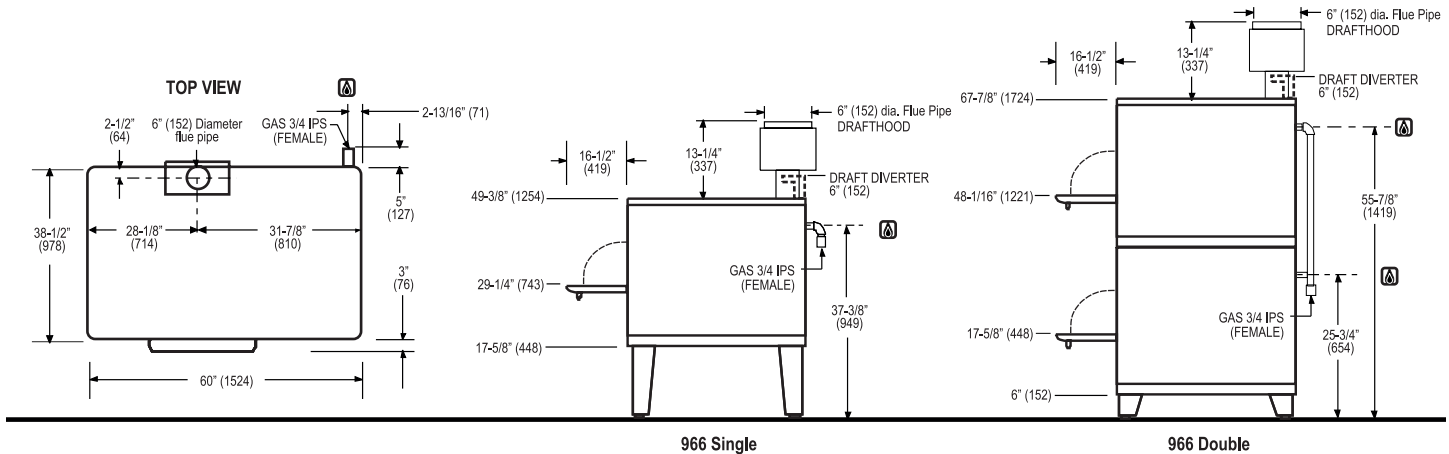

SHORT FORM SPECIFICATIONS

Provide Blodgett (single/double) deck oven, model 966. Construction shall be welded stainless steel front, top, back and sides, and shall be fully insulated on all sides. Oven shall be supported by formed adjustable legs. Door(s) shall be counterbalanced (no springs) with concealed hinges and chrome plated tubular steel handles. Separate burner door provided for ignition, cleaning and adjustment. Each baking compartment shall be 42" W x 16-1/4" H x 32" D and shall be lined with aluminized steel. Deck shall be 11 gauge press-formed, reinforced and flanged steel. Unit shall be gas heated by a free-floating, easily removable, duplex-type burner controlled by a liquid pressure thermostat with range of 200°F to 500°F. Each compartment provided with flue vent. Provide with two year limited parts and one year labor warranty. Provide with options and accessories as indicated.

DIMENSIONS:	Single	Double
Number of sections:	1	2
Number of controls:	1	2
Number of compartments:	1	2
Size of compartment:	(All) 42" (1067mm) W x 16-1/4" (413mm) H x 32" (813mm) D	
Area of each compartment:	9.34 sq. ft. (0.87m ²)	9.34 sq. ft. (0.87m ²)
Total area of oven:	9.34 sq. ft. (0.87m ²)	18.68sq. ft. (1.74m ²)
Clearance below oven:	17-5/8 (448mm)	6" (152mm)
Floor space:	(All) 60" (1524mm) W x 40" (1016mm) D	
Product clearance:	(All) 6" (152mm) from combustible and non-combustible construction	

GAS SUPPLY:
 3/4" IPS connection at rear of oven
 Manifold Pressure:
 • Natural – 5" W.C. • Propane – 10" W.C.
 Inlet Pressure:
 • Natural – 7.0" W.C. min. – 10.5" W.C. max.
 • Propane – 11.0" W.C. min. – 13.0" W.C. max.

MAXIMUM INPUT:
 Single 50,000 BTU/hr
 Double 100,000 BTU/hr.

MINIMUM ENTRY CLEARANCE:
 Uncrated 32-1/2" (826mm)
 Crated 36" (914mm)

SHIPPING INFORMATION:
Approx. Weight:
 Single: 630 lbs. (286kg)
 Double: 1190 lbs. (540kg)
Crate sizes:
 65" (1651mm) x 36" (914mm) x 46" (1168mm)

PAN CAPACITIES:	Single	Double
10" (254mm) pie tins:	12	24
18" x 26" (457mm x 660mm) bun pans:	2	4
9-1/2" x 5" (241mm x 127mm) bread pans:	24	48
9" x 7" (228mm x 178mm) roll pans:	16	32
19" x 4" (483mm x 102mm) pullman pans:	14	28
13" x 16-1/2" (330mm x 419mm) cup tins:	9	18
20" x 28" (508mm x 711mm) roast pans:	2	4
No. 200 pans (324mm x 527mm):	4	8
Bean pots #1:	35	70
#3:	20	40
#6:	12	24
25 lb. (11kg) Turkeys:	5	10

NOTE: The company reserves the right to make substitutions of components without prior notice

