



MT2136E/G

MODEL MT2136E/G Gas/Electric Conveyor Oven



Project _____

Item No. _____

Quantity _____

Blodgett conveyor oven with 21" (533mm) wide belt and 36" (914mm) baking zone length. Single, double or triple stack models are available. All data is shown per oven section, unless otherwise indicated.

EXTERIOR CONSTRUCTION

- Stainless steel front, top and sides
- Aluminized steel back and bottom
- 1-1/2" (38.1mm) Vitreous fiber insulation at bottom, back and top
- Ceramic fiber insulation at blower installation

INTERIOR CONSTRUCTION

- Aluminized steel nozzles and bottom surface
- Adjustable aluminized steel air flow plates at top
- 21" (533mm) stainless steel wire mesh conveyor belt
- Two single inlet blowers above the combustion area or heater for air circulation

OPERATION

- Heat transferred through forced convection (impingement)
- Open vented baking compartment
- Electronic spark ignition control system (gas model)
- Gas power type burner has mixer with adjustable shutter and sight window (gas model)
- Internal gas pressure regulator (gas model)
- Tubular resistance heat (electric model)
- Integral or remote microprocessor based controls with solid state 600°F (315.5°C) maximum thermostat and belt speed control with digital display
- Two blower motors (1/8 HP minimum) with thermal overload protectors
- Three blower area cooling fans

STANDARD FEATURES

- Computerized front mounted controls
- Belt direction: (must specify)
 - left to right right to left
- Product stops
- Oven start-up
- One year parts & labor warranty*

* For all international markets, contact your local distributor.



OPTIONS AND ACCESSORIES

(AT ADDITIONAL CHARGE)

- **Legs/casters:**
 - 17-1/4" (438mm) black legs with casters
 - 23-1/4" (591mm) black legs with casters
 - Triple stack base with casters
- **Shelf extension:**
 - 6" (152mm)
 - 12" (304mm)
- **Conveyor belt configurations:**
 - Twin belt-two 10" (254mm) wide belts
 - Split belt - one 8" (203mm) and one 12" (305mm) belt
- **Flexible gas hose with quick disconnect and restraining device:**
 - 36" (914mm)
 - 48" (1219mm)

Note: Two 48" (1219mm) and one 36" (914mm) hose on triple model

- 10' (3.0M) cord with receptacle (gas model only)
- Side loading glass door and handle
- Stacking rails
- Stainless steel interior (available with remote control ovens only)
- One year additional extended warranty

OPTIONS AND ACCESSORIES

(AT NO ADDITIONAL CHARGE)

- Remote computerized controls



Pizzaovens.com

1.877.FOR.OVEN
367.6836

Since 1999



MODEL MT2136E/G

APPROVAL/STAMP

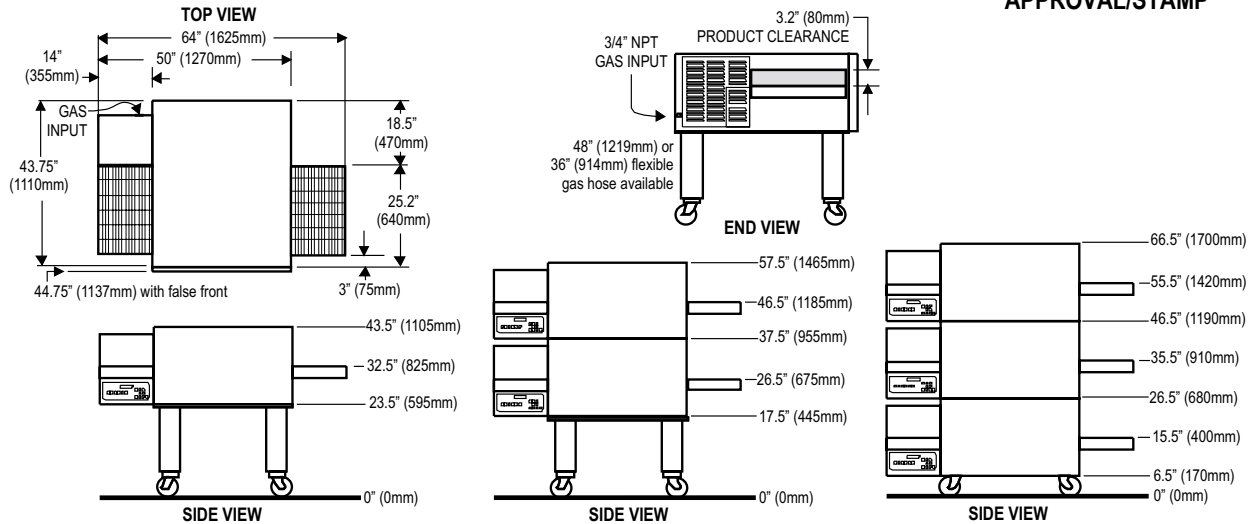

SHORT FORM SPECIFICATIONS
 Provide Blodgett conveyor model MT2136E/G conveyor oven. Unit shall be (gas fired/electrically heated) and shall cook by means of forced, heated air impingement. Unit shall be (single/double/triple) deck supported by (specify stand type from options list). Each deck shall be fully independent, of stainless steel construction, and fully insulated on all sides. Provide with (electronic spark ignition gas fired/electrically heated) baking compartment with two blowers to evenly distribute heat across baking zone. Conveyor belt shall be 21" (535mm) wide and constructed of stainless steel wire mesh; baking zone length shall be 36" (915mm). (Front mounted/remote) control panel shall be solid state with 600°F (315.5°C) maximum thermostat and digital display of adjustable belt speed. Provide start-up inspection service by a factory authorized service agent. Provide options and accessories as indicated.

DIMENSIONS:

| | |
|----------------------------|------------------------------------|
| Floor space | 43.75" (1110mm) W x 64" (1625mm) L |
| Product clearance | 3.2" (80mm) |
| Combustible wall clearance | 0" (0mm) gas and electric |
| Belt width | |
| Standard belt | 21" (535mm) |
| Option twin belt | 10" (255mm) each |
| Split belt | One 8" (203mm) and one 12" (305mm) |
| Baking zone length | 36" (915mm) |

GAS SUPPLY:

3/4" NPT

MAXIMUM INPUT:

| | MT2136G | MT2136E |
|--------|----------------|---------|
| Single | 55,000 BTU/hr | 16 KW |
| Double | 110,000 BTU/hr | 32 KW |
| Triple | 165,000 BTU/hr | 48 KW |

Minimum Gas Pressure: 4.5" W.C. for natural gas
 11.0" W.C. for propane gas
Maximum Gas Pressure: 10.5" W.C. for natural gas
 13" W.C. for propane gas

MINIMUM ENTRY CLEARANCE:

Uncrated 27" (686mm)
 Crated 20" (508mm)

SHIPPING INFORMATION:

| Approx. Weight: | Crated | Uncrated |
|-----------------|--------------------|--------------------|
| Single | 600 lbs. (271 kg) | 460 lbs. (209 kg) |
| Double | 1200 lbs. (543 kg) | 920 lbs. (418 kg) |
| Triple | 1800 lbs. (814 kg) | 1340 lbs. (609 kg) |

*Add: 37 lbs. (17kg) - triple casters; 70 lbs. (32kg) - 17-1/4" legs; 87 lbs. (39kg) - 23-1/4" legs

Crate sizes:

27" (686mm) x 49-1/2" (1257mm) x 72" (1829mm)
 Printed in U.S.A.

POWER SUPPLY (must have dedicated ground)

| MT2136E | V.A.C. | Hz | Phase | K.W. | Amperes | | | |
|-----------------|--------|----|-------|------|---------|----|----|----|
| | | | | | L1 | L2 | L3 | L4 |
| DOMESTIC | | | | | | | | |
| 208 | | 60 | 1 | 16 | 76 | 76 | - | - |
| 240 | | 60 | 1 | 16 | 66 | 66 | - | - |
| 208 | | 60 | 3 | 16 | 44 | 44 | 44 | - |
| 240 | | 60 | 3 | 16 | 38 | 38 | 38 | - |

INTERNATIONAL

| | | | | | | | | |
|---------|--|----|----|----|----|----|----|---|
| 220 | | 50 | 1 | 16 | 73 | 73 | - | - |
| 240 | | 50 | 1 | 16 | 66 | 66 | - | - |
| 220/380 | | 50 | 3N | 16 | 24 | 24 | 24 | - |
| 240/415 | | 50 | 3N | 16 | 23 | 23 | 23 | - |

CE MODEL

| | | | | | | | | |
|---------|--|----|----|----|----|----|----|---|
| 230/400 | | 50 | 3N | 16 | 22 | 22 | 22 | - |
|---------|--|----|----|----|----|----|----|---|

This oven contains a mercury relay. DO NOT put mercury relay in trash. Relay must be recycled or disposed of as hazardous waste.

MT2136G

DOMESTIC

3-wire (incl. neutral and ground) 5 amp. 120/208-240 VAC, 1 phase, 60 Hz.

INTERNATIONAL

3-wire with ground, 4 amp. 220/240 VAC, 1 phase, 50 Hz

CE MODEL

230VAC, 50 Hz, 5 amp., 2 wire with ground

NOTE: The company reserves the right to make substitutions of components without prior notice

BLODGETT OVEN COMPANY

www.blodgettcorp.com

50 Lakeside Avenue, Burlington, VT 05402

Toll Free: (800) 331-5842 • Phone: (802) 860-3700 • Fax: (802) 864-0183

NOTE: FOR COMMERCIAL USE ONLY

P/N M9990 Rev F (6/01)