



MT3855G

MODEL MT3855G Gas Conveyor Oven

Buy this Oven at <http://Pizzaovens.com>



Shown with optional false front

Project _____

Item No. _____

Quantity _____

Blodgett conveyor oven with 38" (965mm) wide belt and 55" (1397mm) baking zone length. Single, double or triple stack models are available. All data is shown per oven section, unless otherwise indicated.

EXTERIOR CONSTRUCTION

- Stainless steel front, top and sides
- Aluminized steel back and bottom
- Side loading glass door and stainless steel handle
- 2" (51mm) Vitreous fiber insulation at top, back and sides
- 1" (25mm) Ceramic fiber insulation top, bottom, front, back and sides

INTERIOR CONSTRUCTION

- Aluminized steel nozzles and bottom surface
- Aluminized steel air flow plates at top
- 38" (965mm) stainless steel wire mesh conveyor belt
- Three single inlet blowers above the combustion area for air circulation

OPERATION

- Heat transferred through forced convection (impingement)
- Open vented baking compartment
- Electronic spark ignition control system
- Gas power type burner has mixer with adjustable shutter and sight window
- Internal gas pressure regulator
- Remote microprocessor based controls with solid state 600°F (315.5°C) maximum thermostat and belt speed control with digital display
- Three blower motors (1/3 HP minimum) with thermal overload protectors
- Centrifugal cooling fan

STANDARD FEATURES

- Computerized remote control
- Folding conveyor
- Belt direction: (must specify)
 - left to right right to left
- Product stops
- Oven start-up
- One year parts & labor warranty*

* For all international markets, contact your local distributor.

OPTIONS AND ACCESSORIES

(AT ADDITIONAL CHARGE)

- **Legs/casters:**
 - 17-1/4" (438mm) black legs with casters
 - 23-1/4" (591mm) black legs with casters
 - Triple stack base with casters
- **Shelf extension:**
 - 6" (152mm)
 - 10" (254mm)
- **Conveyor belt configurations:**
 - Twin belt - two 19" (483mm) belts
 - Split belt - one 8" (203mm) and one 29" (737mm) belt
- **Flexible gas hose with quick disconnect and restraining device:**
 - 36" (914mm)
 - 48" (1219mm)

Note: Two 48" (1219mm) and one 36" (914mm) hose on triple model
- 10' (3.0M) cord with receptacle
- Stacking rail
- One year additional extended warranty*



The Australian Gas Association



Pizzaovens.com

1.877.FOR.OVEN
367.6836

Since 1999



MODEL MT3855G



APPROVAL/STAMP

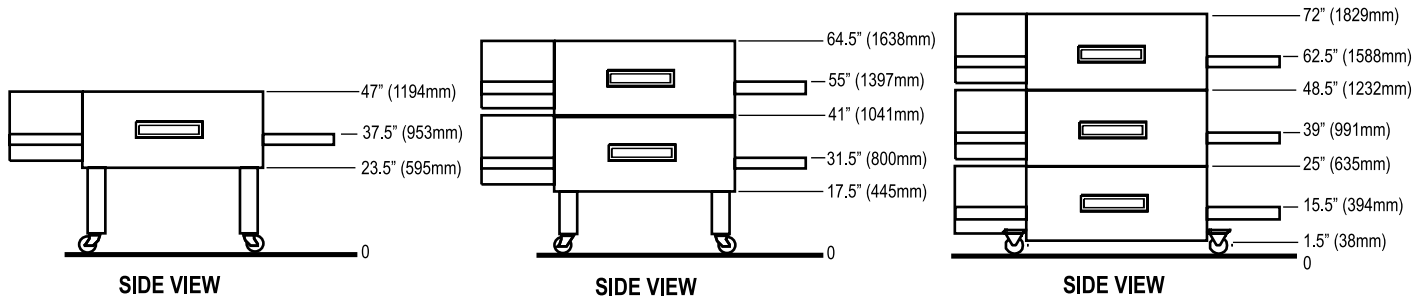
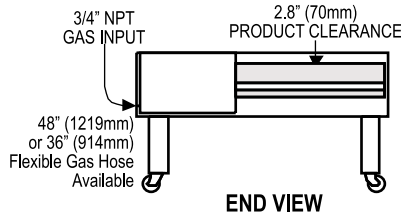
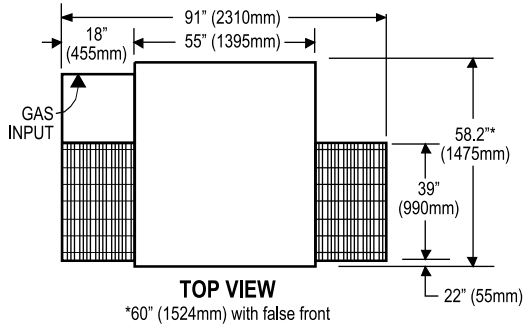

SHORT FORM SPECIFICATIONS

Provide Blodgett Conveyor Oven model MT3855G conveyor oven. Unit shall be gas fired and shall cook by means of forced, heated air (impingement). Unit shall be (single/double/triple) deck supported by (specify stand type from options list). Each deck shall be fully independent, of stainless steel construction, and fully insulated on all sides. Provide with electronic spark ignition gas fired baking compartment with three blowers to evenly distribute heat across baking zone. Conveyor belt shall be 38" (965mm) wide and constructed of stainless steel wire mesh; baking zone length shall be 55" (1395mm). Unit shall be provided with glass side loading door. Remote control panel shall be solid state with 600°F (315.5°C) maximum thermostat and digital display of adjustable belt speed. Provide start-up inspection service by a factory authorized service agent. Provide options and accessories as indicated.

DIMENSIONS:

Floor space	58.2" (1475mm) W x 91" (2310mm) L
Product clearance	2.75" (70mm)
Combustible wall clearance	0" (0mm)
Belt width	
Standard belt	38" (965mm)
Twin belt	Two 18-1/2" (470mm)
Split belt	One 8" (203mm) and one 29" (737mm)
Baking zone length	55" (1395mm)

GAS SUPPLY: (specify)

	Natural	Propane
Single	3/4" NPT	3/4" NPT
Double stack	1" NPT	1" NPT
Triple stack	1-1/4" NPT	1" NPT

MAXIMUM INPUT:

Single	150,000 BTU/hr
Double	300,000 BTU/hr
Triple	450,000 BTU/hr

Minimum Gas Pressure: 4.5" W.C. for natural gas
11.0" W.C. for propane gas

Maximum Gas Pressure: 10.5" W.C. for natural gas
13" W.C. for propane gas

POWER SUPPLY:

Domestic Model:

120/208-240 VAC, 1 Phase, 60 Hz., 9 amp, 3 wire with Ground

Export Model:

240 VAC, 1 phase, 50 Hz., 7 amp, 2 wire with Ground

MINIMUM ENTRY CLEARANCE:

Uncrated	24" (610mm)
Crated	30" (762mm)

SHIPPING INFORMATION:

Approx. Weight: Crated

	Crated	Uncrated
Single	1200 lbs. (545 kg)	1060 lbs. (482 kg)
Double	2400 lbs. (1091 kg)	2012 lbs. (915 kg)
Triple	3600 lbs. (1636 kg)	2968 lbs. (1349 kg)

Crate sizes:

29-1/2" (749mm) x 72" (1829mm) x 93" (2362mm)

NOTE: The company reserves the right to make substitutions of components without prior notice