

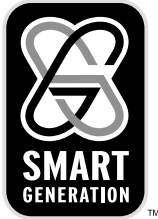

# MODEL SG3240E/G Electric/Gas Conveyor Oven



Project \_\_\_\_\_ Buy this Oven at <http://Pizzaovens.com>  
Item No. \_\_\_\_\_  
Quantity \_\_\_\_\_

SG3240E/G

Blodgett conveyor oven with 32" (813mm) wide belt and 40" (1016mm) baking zone length. Single, double or triple stack models. Base units available for stacking with existing oven.

All data is shown per oven section, unless otherwise indicated.

### EXTERIOR CONSTRUCTION

- Stainless steel front, top and sides
- Aluminized steel back and bottom
- Full drop down easily removable side door
- Foil faced ceramic fiber insulation

### INTERIOR CONSTRUCTION

- Aluminized steel nozzles and bottom surface
- Adjustable aluminized steel air flow plate at top
- 32" (813mm) stainless steel wire mesh conveyor belt
- Two single inlet blowers above the combustion/element area for air circulation

### OPERATION

- Heat transferred through forced directed hot air convection
- Open vented baking compartment
- Electronic spark ignition control system (gas model)
- Gas power type burner has mixer with adjustable shutter and sight window (gas model)
- Internal gas pressure regulator (gas model)
- Tubular resistance elements (electric model)
- Integral or remote microprocessor based controls with solid state 600°F (315°C) maximum thermostat and belt speed control with backlit LCD display
- Two circulation blower motors with thermal overload protectors
- 1-30 minute bake time

### STANDARD FEATURES

- Front mounted computerized control options: *(must specify)*
  - manual       menu (4 program keys, stores time/temp settings)
- Self diagnostics, monitors and alerts operator of warning or fault conditions
- Belt direction: *(must specify)*
  - left to right       right to left
- Large side loading door with window and stainless steel handle
- Product stop
- Cord set and plug (NEMA L6-15P) domestic gas ovens only
- Non-folding removable conveyor belt assembly
- Oven start-up\*
- One year parts & labor warranty\*

\* For all international markets, contact your local distributor.



### OPTIONS AND ACCESSORIES (AT ADDITIONAL CHARGE)

- **Legs/casters:**
  - 17-1/4" (438mm) black legs with casters
  - 23-1/4" (591mm) black legs with casters
  - Triple stack base with casters
- **Shelf extension:**
  - 10" (254mm)
  - 15" (381mm)
  - 20" (508mm)
- **Remote control:**
  - 10' (3.0M) cable
  - 50' (15.24M) cable
- **Flexible gas hose with quick disconnect and restraining device:**
  - 36" (914mm)
  - 48" (1219mm)

Note: Two 48" (1219mm) and one 36" (914mm) hose on triple model

- Twin belt - two 15-3/4" (400mm) wide belts
- Stainless steel interior (available with remote control ovens only)
- Foldable conveyor belt support assembly
- One year additional extended warranty\*



**Pizzaovens.com**

1.877.FOR.OVEN  
367.6836

Since 1999

# MODEL SG3240E/G

APPROVAL/STAMP

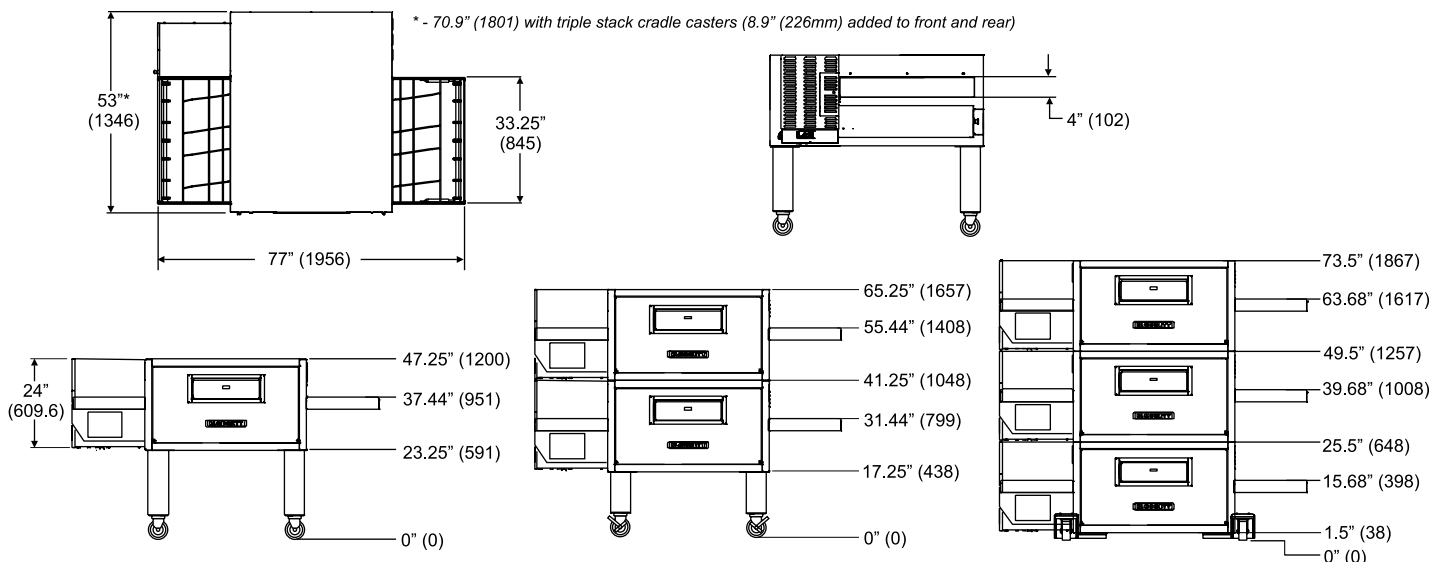

## SHORT FORM SPECIFICATIONS

Provide Blodgett conveyor model SG3240(G/E) conveyor oven. Unit shall be (gas fired/electrically heated) and shall cook by means of forced, heated air. Unit shall be (single/double/triple) deck supported by (specify leg height from options list). Each deck shall be fully independent, of stainless steel construction, and fully insulated on all sides. Provide with (electronic spark ignition gas fired/electrically heated) baking compartment with two blowers to evenly distribute heat across baking zone. Conveyor belt shall be 32" (813mm) wide and constructed of stainless steel wire mesh; baking zone length shall be 40" (1016mm). Unit shall be provided with drop down front door. (Front mounted/remote) control panel shall be solid state with 600°F (315.5°C) maximum thermostat and LCD display of 1-30 minutes adjustable belt speed. Provide start-up inspection service by a factory authorized service agent. Provide options and accessories as indicated.

## DIMENSIONS:

<b>Floor space</b>	53" (1346mm) W x 77" (1956mm) L
<b>Product clearance</b>	4" (102mm)
<b>Combustible wall clearance</b>	0" (0mm)
<b>Belt width</b>	
Standard belt	32" (813mm)
Optional twin belt	15-3/4" (400mm) each
<b>Baking zone length</b>	40" (1016mm)

## MAXIMUM HEAT INPUT:

	<b>SG3240G</b>	<b>SG3240E</b>
Single	110,000 BTU/hr (32.2KW) (116MJ/hr)	27 KW
Double	220,000 BTU/hr (64.4KW) (232MJ/hr)	54 KW
Triple	330,000 BTU/hr (96.6KW) (348MJ/hr)	81 KW

## GAS SUPPLY: (specify)

	<b>Natural</b>	<b>Propane</b>
Single	3/4" NPT	3/4" NPT
Double stack	1" NPT	3/4" NPT
Triple stack	1" NPT	1" NPT

**Minimum Gas Pressure:** 4.5" W.C. for natural gas  
11.0" W.C. for propane gas

**Maximum Gas Pressure:** 10.5" W.C. for natural gas  
13" W.C. for propane gas

**NOTE:** The company reserves the right to make substitutions of components without prior notice

## POWER SUPPLY (must have dedicated ground)

### SG3240E:

V.A.C.	Hz	Phase	K.W.H.	Amperes			
				L1	L2	L3	N

### DOMESTIC

208	50/60	3	28	78	78	78	-
240	50/60	3	28	68	68	68	-

### INTERNATIONAL

230/400	50/60	3N	28	41	39	39	3
240/415	50/60	3N	28	39	38	38	3

This oven contains a mercury relay. DO NOT put mercury relay in trash. Relay must be recycled or disposed of as hazardous waste.

**SG3240G:** 2-wire plus ground, 5 amp. 208-240 VAC, 1 phase, 50/60 Hz.

## MINIMUM ENTRY CLEARANCE:

Uncrated	25" (635mm)
Crated	31" (788mm)

## SHIPPING INFORMATION:

Approx. Weight:	Crated	Uncrated
Single	850 lbs. (385 kg)	750 lbs. (340 kg)
Double	1700 lbs. (770 kg)	1500 lbs. (680 kg)
Triple	2550 lbs. (1160 kg)	2250 lbs. (1020 kg)

## Crate size:

29-1/2" (750mm) x 72" (1830mm) x 93-1/2" (2375mm)