



Pizzaovens.com

1.877.FOR.OVEN  
367.6836

Since 1999

Base Models: F3218, F3430, F3218B, F318B

# 48" Wide Ranges



## Standard Features & Benefits

**OVENS:** Large oven measures 31.5" w x 22" d x 14" h for superior baking characteristics and results. Small ovens measure 19.5" w x 22" d x 14" h. Heavy insulation for fuel efficiency. Easy cleaning porcelain and aluminized linings with one nickel plated rack. 3 rack positions with 2.5" between rack positions. Large ovens feature long life, 30,000 BTU cast iron "H" pattern oven burner. Small oven is rated at 25,000 BTU. Special "V" shaped baffle directs heat for excellent air circulation.

**COOK TOPS:** 24,000 BTU "star" pattern top burners offer a more efficient burn pattern for small to large pots. Full width crumb trays catch all spillage. Top grates are 12" x 12" cast iron with spillover bowl that also reflects heat for added efficiency. Designed for easy movement of pots across top sections. Wide, stainless steel bull nose landing across the front is a functional work area for service plates and work utensils and also serves as control protection.

**CONSTRUCTION:** Easy cleaning, corrosion resistant stainless steel finish, welded with angle iron and aluminized inner framing. Sturdy 6" heavy duty stainless pipe legs with adjustable feet. Double wall construction with heavy insulation for cooler operation. Installation clearances for non-combustible surfaces are 0" on sides and 0" in the rear, combustible surface clearances are 2" and 2".

**CONTROLS:** Includes 500° thermostat, 100% safety shut off, automatic standing pilot and brass top burner valves. Pressure regulators are set at the factory for the gas specified. Optimal pressures are 4" WC for natural gas and 10" WC for propane. Manifold size is 3/4" NPT. All controls are tested and confirmed in good working order. Calibration and adjustments are the responsibility of the installer.

## Optional Features

**GRIDDLE PLATES:** Available in 12" width increments. 3/4" thick to hold heat from long life, 20,000 BTU cast iron "H" pattern burners. Plates also feature a front "cold zone" grease trough and large capacity grease catch. Thermostats, safety pilots, chrome and thicker plates are also available. Cheesemelter-broiler griddles feature one "H" burner with stainless steel mesh radiants, 18" x 18" broiler rack and a rear drain.

**RADIANT CHAR-BROILERS:** 25,000 BTU cast iron "H" pattern burners. Cast iron top grate sections fit into 12" width increments. A cast-in trough on each blade channels grease into the front cold zone grease trough reducing flare up. Each section is reversible for sloped or level cooking. Stainless steel splash guards on 3 sides graduating up to 4" high. Grease slot is 3.5" x 1" and feeds into a large, removable grease drawer. Char-broilers are approved for use in non-combustible locations only.

**HOT TOPS:** Available in 12" width increments in lieu of open top burners. 3/4" thick to hold heat from long life, even heating 20,000 BTU cast iron "H" pattern burners.

**ACCESSORIES & OPTIONS:** Casters, extra racks, pizza decks, FD oven thermostats, oven spark pilots, chrome griddle plates, 1" thick griddle plates, griddle thermostats, safety pilot griddles, lift off griddles, grill scrapers, cleaning supplies, hose and quick disconnects, control protection bars, storage base in lieu of oven and low backs are some of the standard options and accessories available.



**48" WIDE SERIES MEASUREMENTS**

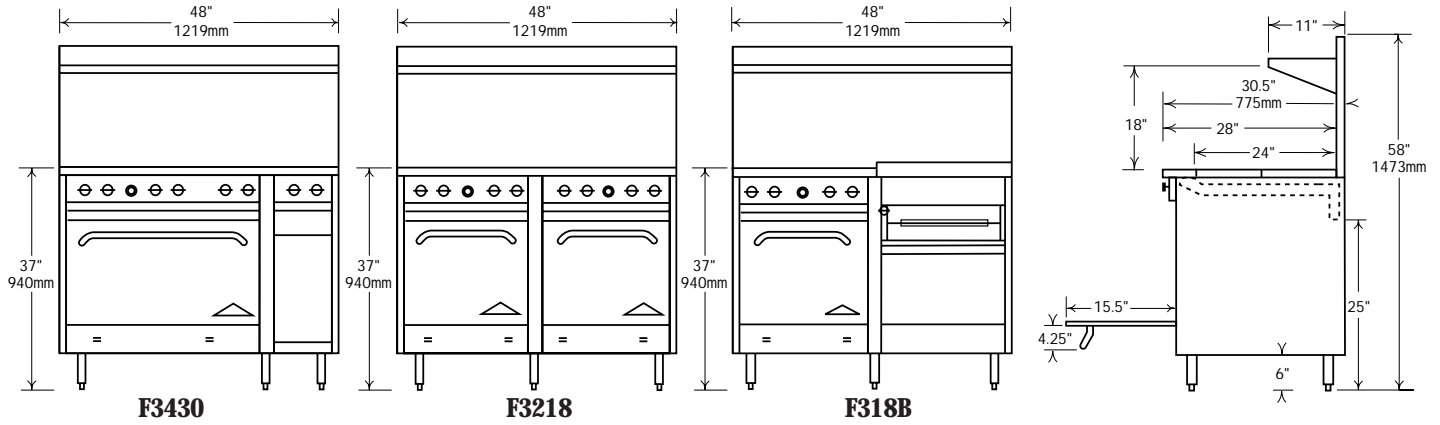

**48" Restaurant Range Series**

Top Configuration	Model #	Description		Total B.T.U.	Approx. Ship Weight	
		Top	Base		(Kg)	(Lbs.)
	F3218	(8) Open Burners	- w/ (2) 19.5" Ovens	242,000	309	680
	F3430	(8) Open Burners	- w/ (1) 31.5" Oven & 10" storage space	222,000	291	640
	F3218-12	(6) Open Burners & (1) 12" Griddle	- w/ (2) 19.5" Ovens	214,000	298	655
	F3430-12	(6) Open Burners & (1) 12" Griddle	- w/ (1) 31.5" Oven & 10" storage space	194,000	286	660
	F3218-24	(4) Open Burners & (1) 24" Griddle	- w/ (2) 19.5" Ovens	186,000	302	665
	F3430-24	(4) Open Burners & (1) 24" Griddle (reversed / on left)	- w/ (1) 31.5" Oven & 10" storage space	166,000	293	645
	F318B	(4) Open Burners & (1) 24" Griddle/Broiler	- w/ (1) 19.5" Oven & 21" storage space	146,000	280	615
	F3218B	(4) Open Burners & (1) 24" Griddle/Broiler	- w/ (2) 19.5" Ovens	171,000	316	695
	F3218-36	(2) Open Burners & (1) 36" Griddle	- w/ (2) 19.5" Ovens	158,000	318	700
	F3430-36	(2) Open Burners & (1) 36" Griddle	- w/ (1) 31.5" Oven & 10" storage space	138,000	277	610
	F318B-36	(2) Open Burners & (1) 36" Griddle, 18" Broiler	- w/ (1) 19.5" Oven & 21" storage space	123,000	291	640
	F3218-48	(0) Open Burners & (1) 48" Griddle	- w/ (2) 19.5" Ovens	130,000	345	760
	F3430-48	(0) Open Burners & (1) 48" Griddle	- w/ (1) 31.5" Oven & 10" storage space	110,000	305	670
	F318B-48	(0) Open Burners & (1) 48" Griddle, 18" Broiler	- w/ (1) 19.5" Oven & 21" storage space	95,000	357	785

**Note:** Radiant char-broiler sections and hot top available, add suffix -1RB, -2RB or -1HT, -2HT, etc. per section. Top sections in lieu of open top burners are located on the right when viewing from the front. Special locations may require custom work and pricing, please call the factory for details.

**Crated Dimensions:** 55" (1397mm) Wide x 41" (1041mm) Deep x 40" (1016mm) High.

Product improvement is a Comstock-Castle policy and may result in design and specification change without notice.

