



America's Oldest Stove Company  
(Est. 1838)



Pizzaovens.com

1.877.FOR.OVEN  
367.6836

Since 1999

Base Models: F3218, F3430, F3218B, F318B

# 48" Wide Ranges

F3218-24B



F3218-18-1.5RB  
(shown with extra racks  
and optional casters)



F3218

-2RB



F3430-24  
(shown with griddle on left)

## Standard Features & Benefits

**OVENS:** Large oven measures 31.5" w x 22" d x 14" h for superior baking characteristics and results. Small ovens measure 19.5" w x 22" d x 14" h. Heavy insulation for fuel efficiency. Easy cleaning porcelain and aluminized linings with one nickel plated rack. 3 rack positions with 2 3/4" between rack positions. Large oven features long life, 30,000 BTU cast iron "H" pattern oven burner. Small ovens are rated at 25,000 BTU. Special "V" shaped baffle directs heat for excellent air circulation.

**COOK TOPS:** 24,000 BTU "star" pattern top burners with no gaskets to leak. The large 7" flame spread offers a more efficient burn pattern for small to large pots. Full width crumb trays catch all spillage. Top grates are 12" x 12" cast iron with spillover bowl that also reflects heat for added efficiency. Designed for easy movement of pots across top sections. Stainless steel bullnose-rail is safely flush with the cook tops and functional to straddle pots, skillets and plastes and also serves as control protection.

**CONSTRUCTION:** Easy cleaning, corrosion resistant stainless steel finish, welded with angle iron and aluminized inner framing. Sturdy 6" heavy duty stainless pipe legs with adjustable feet. Double wall construction with heavy insulation for cooler operation. Installation clearances for non-combustible surfaces are 0" on sides and 0" in the rear, combustible surface clearances are 2" and 2".

**CONTROLS:** Includes 500° thermostat, 100% safety shut off, automatic standing pilot and brass top burner valves. Pressure regulators are set at the factory for the gas specified. Optimal pressures are 4" WC for natural gas and 10" WC for propane. Manifold size is 3/4" NPT. All controls are tested and confirmed in good working order. Calibration and adjustments are the responsibility of the buyer.

## Optional Features

**GRIDDLES:** 12" increments have 20,000 BTU cast iron burners replacing front to back open burner pairs. 18" & 30" sections feature 2 & 4 "I" burners respectively, rated at 18,000 BTU each, available only when matched together with 18" or 30" char-broilers. 3/4" thick is standard. SS splash guards tapering to 4". Front grease trough and large capacity grease catch. Optional raised griddle-cheesemelters with rear trough are available up to 36". Maximum rack clearance is 4 1/2".

**CHAR-BROILERS:** 12" increments have 25,000 BTU cast iron burners replacing front to back open burner pairs. 18" & 30" sections feature 2 & 4 "I" burners respectively, rated at 20,000 BTU each, available only when matched together with 18" or 30" griddles. Flare up reducing cast iron top grates and radiants for superior heat retention. Front grease trough and large capacity grease catch. SS splash guards tapering to 4". Char-broilers are approved for use in non-combustible locations only.

**HOT TOPS:** Available in 12" width increments in lieu of open top burners. 3/4" thick to hold heat from long life, even heating 20,000 BTU cast iron "H" pattern burners.

**ACCESSORIES & OPTIONS:** Casters, extra racks, pizza decks, FD oven thermostats, oven spark pilots, chrome griddle plates, 1" thick griddle plates, griddle thermostats, safety pilot griddles, lift off griddles, grill scrapers, cleaning supplies, hose and quick disconnects, control protection bars, storage base in lieu of oven and low backs are some of the standard options and accessories available.



**48" WIDE SERIES MEASUREMENTS**

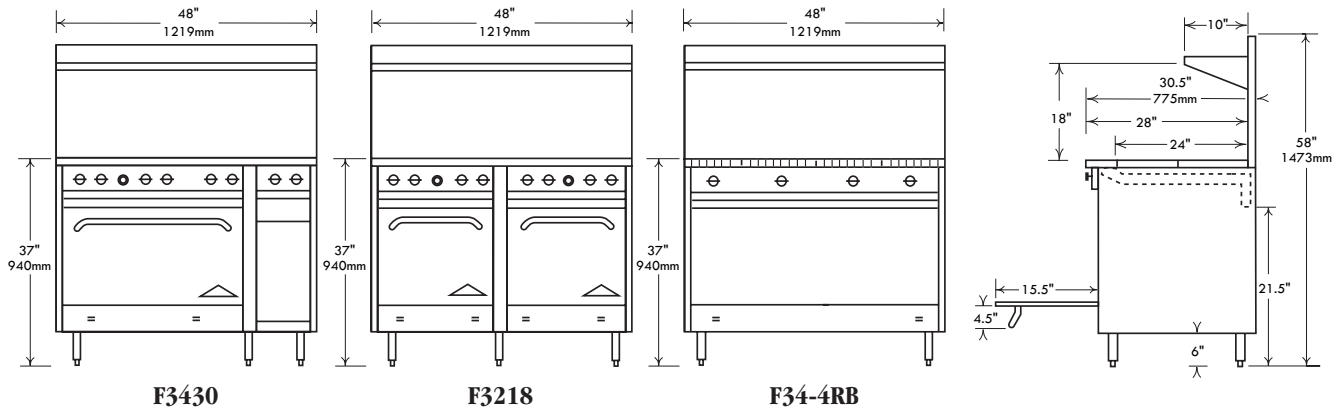

**48" Restaurant Range Series** Note: Radiant char-broiler sections and hot top available, add suffix -1RB, -2RB or -1HT, -2HT, etc. per section.

Top Configuration	Model #	Description		Total B.T.U.	Approx. Ship Weight	
		Top	Base		(Kg)	(Lbs.)
	F3218	(8) Open Burners	- w/ (2) 19.5" Ovens	242,000	309	680
	F3430	(8) Open Burners	- w/ (1) 31.5" Oven & 10" storage space	222,000	291	640
	F3218-24	(4) Open Burners & (1) 24" Griddle	- w/ (2) 19.5" Ovens	186,000	302	665
	F3430-24	(4) Open Burners & (1) 24" Griddle	- w/ (1) 31.5" Oven & 10" storage space	166,000	293	645
	F3430-24B*	(4) Open Burners & (1) 24" Griddle, 18" cheesemelter	- w/ (1) 31.5" Oven & 10" storage space	156,000	291	640
	F31832-24B	(4) Open Burners & (1) 24" Griddle, 18" cheesemelter	- w/ (1) 19.5" Oven & 21" storage space	151,000	280	615
	F3218-24B	(4) Open Burners & (1) 24" Griddle, 18" cheesemelter	- w/ (2) 19.5" Ovens	176,000	316	695
	F3218-36	(2) Open Burners & (1) 36" Griddle	- w/ (2) 19.5" Ovens	158,000	318	700
	F3430-36	(2) Open Burners & (1) 36" Griddle	- w/ (1) 31.5" Oven & 10" storage space	138,000	277	610
	F31832-36B	(2) Open Burners & (1) 36" Griddle, 18" cheesemelter	- w/ (1) 19.5" Oven & 21" storage space	123,000	291	640
	F3430-36B*	(2) Open Burners & (1) 36" Griddle, 30" cheesemelter	- w/ (1) 31.5" Oven	138,000	272	598
	F3218-36B*	(2) Open Burners & (1) 36" Griddle, 30" cheesemelter	- w/ (2) 19.5" Ovens	158,000	312	686
	F3218-18-1.5RB	(2) Open Burners & (1) 18" Griddle & (1) 18" Radiant Broiler	- w/ (2) 19.5" Ovens	174,000	318	700
	F3430-18-1.5RB	(2) Open Burners & (1) 18" Griddle & (1) 18" Radiant Broiler	- w/ (1) 31.5" Oven	154,000	277	610

Top sections in lieu of open top burners are located on the right when viewing from the front. Special locations may require custom work and pricing, please call for details.

**Approximate Packaging Dimensions:** 55" (1397mm) Wide x 41" (1041mm) Deep x 40" (1016mm) High.

Product improvement is a Comstock-Castle policy and may result in design and specification change without notice.

**Gas connection location** as you look from the front:

3430 series; 21.5" from the floor, 3" & 39" from the left side.

3218 & F31832 series; 21.5" from the floor, 3" & 27" from the left side.

F3218-24B series; 21.5" & 30.5" from the floor, 3" & 39" from the left side.

\*not ETL design listed



**Pizzaovens.com**

1.877.FOR.OVEN  
367.6836

Since 1999

