



**Pizzaovens.com**

**Your Complete Source  
for buying the right equipment**

ITEM NUMBER \_\_\_\_\_

JOB NAME / NUMBER \_\_\_\_\_

## **CR-28 & CR-32**

ROTISSERIE & HOLDING OVEN  
FLOOR MODEL - GAS FIRED

### **Cleveland Standard Features**

- Single Convection Rotisserie Oven has the capacity for 7 or 8 cooking skewers or 28 or 32 chickens per unit, cooked to perfection in about 90 minutes.
- Reliable, easy to use Electric Controls with LED Indicators.
- Automatic Oven Preheat controls
  - 16 Programmable Recipe memory settings
  - Automatic Holding Cycle
  - Product Co-cook Feature
  - Oven Cavity Temperature "Set-Back" Feature
  - Rotisserie advance control for loading and removing skewers
  - Door Safety Switch
- Powerful 60,000 BTU "High Stage" or "48,000 BTU" Low Stage Ceramic Gas Burner System with Electronic Spark Ignition for easy start-up operation. Power switch automatically ignites burners and starts fans and preheat cycle.
- Unit comes with 1 set of Stainless Steel Skewers.
- The Cleveland Rotisserie Oven comes standard with a heavy-duty stainless steel stand with two hinged doors and bottom shelf. Mounted on four heavy-duty adjustable casters: 2 locking and 2 swivel.
- External mounted Oven Light for enhanced visual appeal.
- Standard Left Hand Door hinging and Large Glass Window. Fully insulated cooking compartment. Safety Switch stops fans, burners and rotisserie when door is open.
- Standard 115 volt, 60Hz. Single phase with cord & plug.
- Oven Catch Pan with skimmer drain for safe, easy cleaning.
- "Set-Back" control automatically lowers temperature to 200°F after 20 minutes of idle use.
- Approvals: ETL, ETL, ETL Sanitation.

### **Options & Accessories**

- Prep Table, 42" x 32" (PRT4232)
- CBS-32 Cabinet Base Stand
- Small Skewers (under 3 lbs), set of 7 (SK-28S), set of 8 (SK-32S)
- Large Skewers (over 3 lbs), set of 7 (SK-28L), set of 8 (SK-32L)
- Skewer Rack (RSR)
- TB-32 Turkey Breast Basket, 1 each



### **Short Form Specifications**

CR-\_\_ Rotisserie Oven: Dual rate, high and low fire stage burner. Three rotisserie speeds to dial in the right combination for perfect browning capabilities. 16 programmable menu buttons with auto hold feature.

- TBW-32 Turkey Breast Basket Wrench, set of 2
- PB-7 Planetary Bearings, set of 7
- PB-8 Planetary Bearings, set of 8
- RI-32 Roller Tray Assembly for transporting Skewers
- SKH-32 Skewer Handling Tools, set of 2
- CSH-32 Skewer Adapter Holder for counter-top

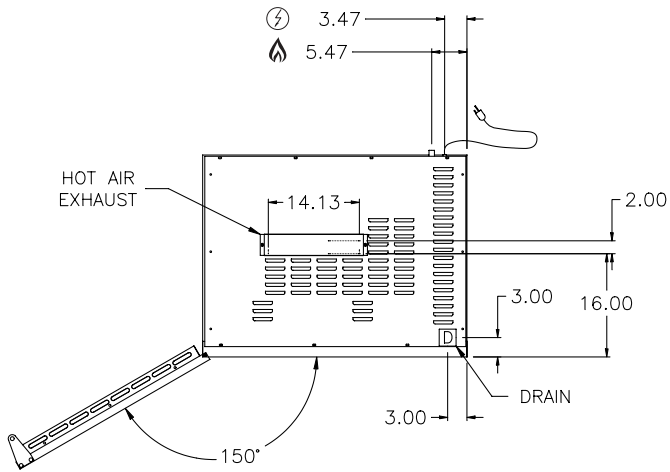

NOTE:

THE UNIT MUST HAVE BETWEEN 5 AND 14" OF NATURAL GAS PRESSURE WITH THE FACILITY IN FULL OPERATION.

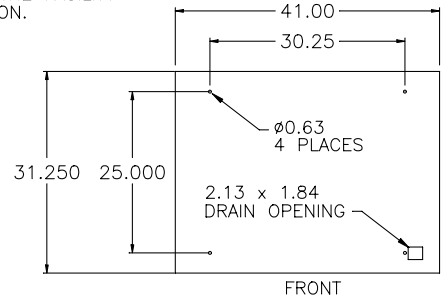

TOP VIEW OF ROTISSERIE SHOWING MOUNTING LOCATIONS

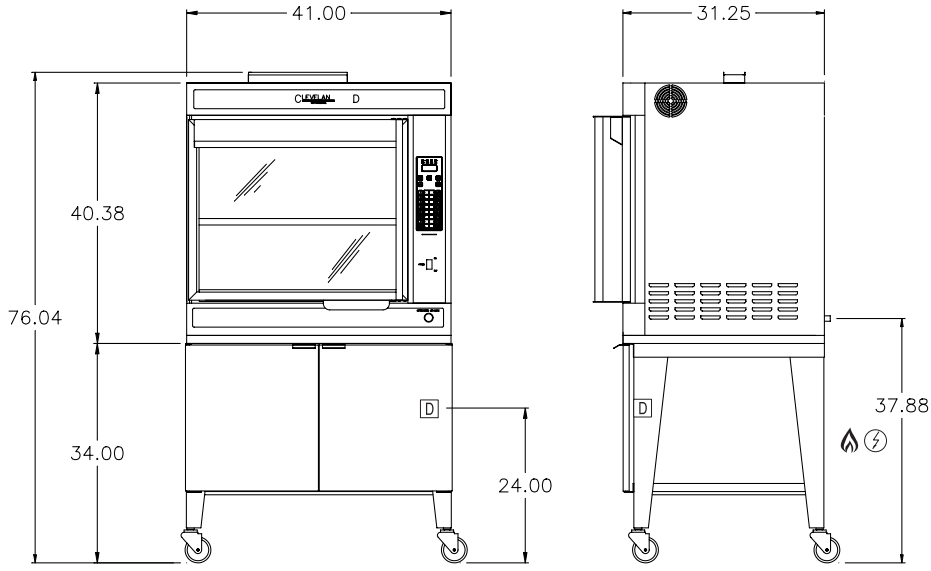

MODEL	CAPACITY	INPUT CHART	SERVICE CONNECTIONS	INSTALLATION NOTES
CR-32	8 Skewers or 8 Turkey Baskets	Natural Gas 60,000 BTU per hours max.	<p> <b>Electrical Connection-</b> supplied with 8 ft. cord</p> <ul style="list-style-type: none"> <li>- 1 PH grounded outlet</li> <li>- 9 AMP max.</li> </ul> <p> <b>Gas Connection -</b> 3/4" NPT</p> <p> <b>Drain -</b> Drain Kit supplied with Rotisserie</p>	<p>Suitable for installation on combustible floors</p> <p>Min. clearance to combustile or non-combustible walls: Sides - 3", Back - 6"</p> <p>Gas Pressure Required: Natural - 5"-14" WC Propane - 11"- 14" WC</p> <p>Normal Supply Pressures</p> <p><b>Gas Input Ratings -</b> Ratings shown are for Natural and LP Gas installations Specify altitude of project if over 2000 ft. (610 meters) For other gases specify type, calorific value, specific gravity and pressure at appliance</p> <p><b>NOTE:</b> When ordering specify type of gas to be used</p>