



# Delfield



Pizzaovens.com

1.877.FOR.OVEN  
367.6836

Since 1999

## 18PTB

### Single/Double Section Self-Contained Refrigerated Pizza Prep Tables

#### MODELS:

18648PTB

48" Pizza Prep Table  
12 pan capacity

18660PTB

60" Pizza Prep Table  
14 pan capacity

18672PTB

72" Pizza Prep Table  
18 pan capacity



Model 18660PTB

#### STANDARD FEATURES

- Top, sides and ends are constructed of 18-gauge stainless steel
- Units are mechanically cooled with diestamped openings to accommodate 12" x 20" hotel pans or fractional pans
- Pans and adapter bars by others
- Pans are recessed 2" to provide proper cooling for NSF 7
- High density polyurethane foam throughout unit
- Dart style quick change gaskets
- Stainless steel removable hinged covers
- On/off switch and rail on/off is located behind the louver
- Front louver is hinged for access to condensing unit and allow adequate air flow back of the unit
- 8' long electrical cord
- Environmentally friendly HFC-404A refrigerant
- One year parts and 90 day labor standard warranty

#### OPTIONS AND ACCESSORIES

- Stainless steel back
- Laminate facing (full front)
- Laminate end
- Laminate back
- Tray racks
- Cutting board (.5" x 20")
- Legs, set of four
- Legs, set of six
- Cheese grates with removable catch pans
- 18" deep single tier stainless steel oversshelf
- 19" wide refrigerated drawers (2) high, holds 6" deep pans
- 19" wide refrigerated drawers (3) high, holds 4" deep pans
- 27" wide refrigerated drawers (2) high, holds 6" deep pans
- 27" wide refrigerated drawers (3) high, holds 4" deep pans
- Lock
- \*220V/50 cycle electrical system
- Additional shelf (specify door size)

\*Inclusion of this option will alter the electrical specifications of the unit



#### SPECIFICATIONS

**Exterior Top:** Constructed of one-piece 18-gauge stainless steel, with integral 2.12" (5.4cm) high square nosing at the front. Top has a mechanically cooled refrigerated raised rail at the rear with openings to accommodate pans (provided by others). Rail interior is 22-gauge stainless steel. Raised rail openings have 20-gauge stainless steel removable lids. Unit is equipped with separate expansion valve and on/off switch for refrigerated rail. Temperature in top openings maintains 33°F (1°C) to 41°F (5°C) with pans recessed 2" (5.1cm) at 86°F ambient room temperature, meeting NSF 7 requirements.

**Exterior Back and Bottom:** 24-gauge galvanized steel. Exterior ends are finished with stainless steel.

**Base Interior:** Stainless steel back and bottom. Base interior sides and door frames are thermoformed ABS plastic. Each interior door section has (1) 25" (63.5cm) deep removable epoxy coated wire shelf. Base is insulated with 2" (5.1cm) high density foamed in place polyurethane. End of base has a machine compartment with condensing unit installed.

**Door(s):** 22-gauge stainless steel exterior front, with a thermoformed ABS plastic interior liner.

**Refrigeration System:** HFC-404A refrigerant. Cabinet has a blower coil assembly with expansion valve (1) on 48", 60" and 72" models, located in coil housing. Base is equipped with independently controlled thermostat, solenoid valve and condensate evaporator. Refrigerated base maintains temperature of 36°F (2°C) to 40°F

(4°C). Recessed on/off switches for rail and base are located behind the hinged louver door.

**Electrical Connections:** 115 volt, 60 Hertz, single phase. Unit is wired with 3-wire, grounded, maximum 8' (2.4m) cord and plug.

**Castors:** Equipment is mounted on 5" (12.7cm) diameter casters; overall height of casters is 6.13" (15.6cm).

18PTB Single/Double Section Refrigerated Pizza Prep Tables



# 18PTB SINGLE/DOUBLE SECTION PIZZA PREP TABLE

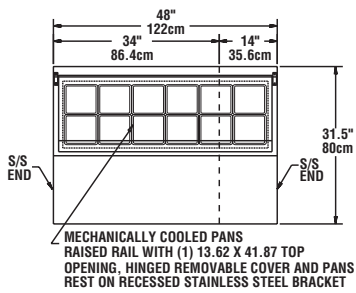

**PLAN VIEW  
18648PTB**

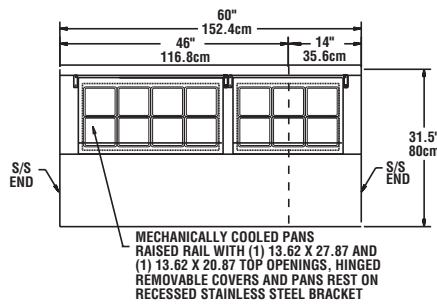

**PLAN VIEW  
18660PTB**

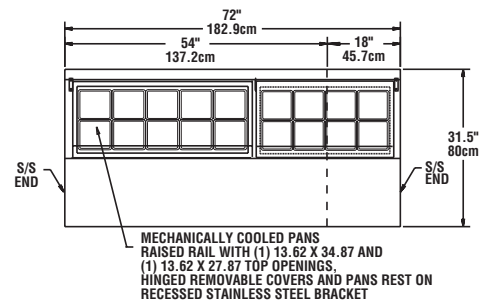

**PLAN VIEW  
18672PTB**

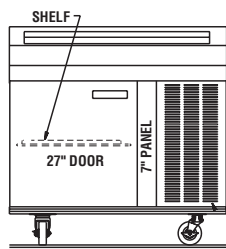

**ELEVATION VIEW  
18648PTB**

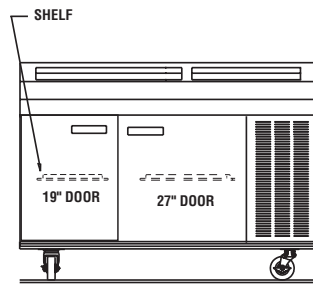

**ELEVATION VIEW  
18660PTB**

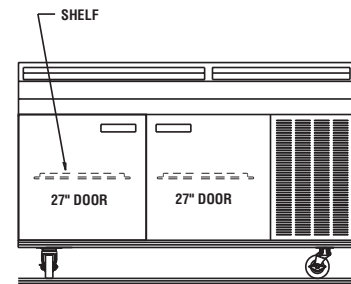

**ELEVATION VIEW  
18672PTB**

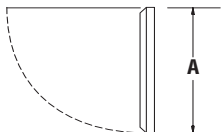

19" DOOR (A= 19.5" or 49.5cm)  
 27" DOOR (A= 27.5" or 70cm)  
 32" DOOR (A= 32.5" or 82.5cm)

**DOOR CLEARANCE DETAIL  
ALL MODELS**

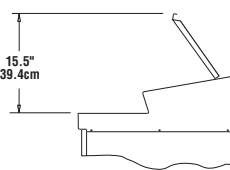

**LID HEIGHT DETAIL  
ALL MODELS**

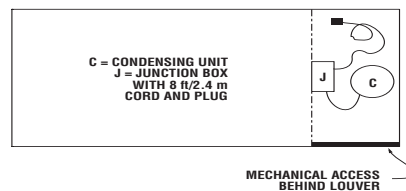

**MECHANICAL ACCESS  
(PLAN VIEW) ALL MODELS**

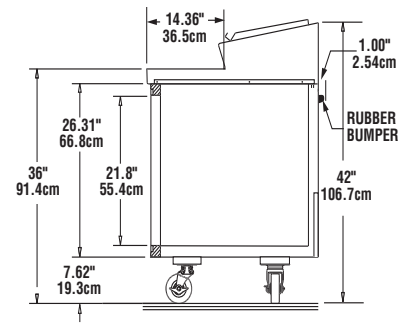

**TYPICAL END VIEW  
ALL MODELS**

**NOTE: PANS AND ADAPTER  
BARS ARE NOT INCLUDED**

## Mechanical Data—Standard Unit

MODEL NUMBER	PAN CAP.	# OF SHELVES	STORAGE CU. FT.	SHELF AREA SQ. FT.	STORAGE CAP.	H.P.	VOLTAGE	AMPS	NEMA PLUG	SHIP WEIGHT
18648PTB	12	1	8.39	3.36	8.39ft <sup>3</sup>	1/4	115	10.0	5-15P	520lbs
18660PTB	14	2	14.31	5.63	14.31ft <sup>3</sup>	1/3	115	12.0	5-15P	580lbs
18672PTB	18	2	16.77	7.72	16.77ft <sup>3</sup>	1/2	115	14.0	5-20P	635lbs