



Delfield

402

Self-contained compact work top refrigerators



Model 402

Short form specifications

Exterior top shall be one-piece, 22-gauge stainless steel with front edge turned down to form nosing and rear edge turned up to form a 2" (5.1 cm) thick by 4" (10.2 cm) high backsplash.

Exterior back and bottom shall be one-piece 24-gauge galvanized metal. Exterior ends shall be 22-gauge stainless steel.

Base interior shall be one-piece thermoformed ABS plastic material, with integral shelf supports. Base shall be fully insulated with high-density foamed-in-place polyurethane.

Doors shall have a 22-gauge stainless steel exterior, with a thermoformed ABS plastic interior liner, and shall be fully insulated with foamed-in-place polyurethane. Door handles shall be black, recessed and shall extend the full length of the top of the door. Cabinet shall have (2) adjustable epoxy-coated wire shelves installed.

Refrigeration system shall use HFC-404A refrigerant. Compressor shall be $\frac{1}{2}$ h.p., with condenser coil and hot gas condensate evaporator mounted on rear of cabinet. Evaporator coil and temperature control shall be mounted on the interior rear wall of the cabinet. Refrigerant flow shall be controlled by a capillary tube. Cabinet shall maintain 36°F to 40°F (2°C to 4°C) interior cabinet temperature.

Electrical connections shall be 115 volt, 60 Hertz, single phase. Unit shall have a 7' (2.1 m) long electrical cord and NEMA 5-15P plug. Cord and plug shall be located on rear of cabinet, centered left to right, 16" (40.6 cm) above floor.

Equipment shall be mounted on 6" (15.2 cm) high metal legs with black enamel finish.

Optional accessories & modifications

Stainless steel back

Plastic laminate on front

Additional wire shelves

Stainless steel single-tier overshelf

3.5" (8.9 cm) diameter casters

5" (12.7 cm) diameter casters

Door lock

Full-size composite-type cutting top

220 volt, 50 Hertz electrical system

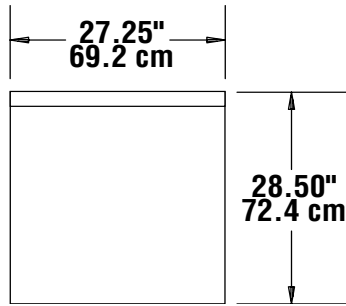
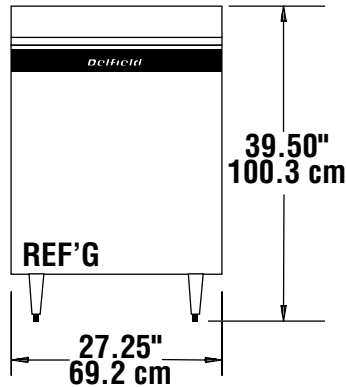
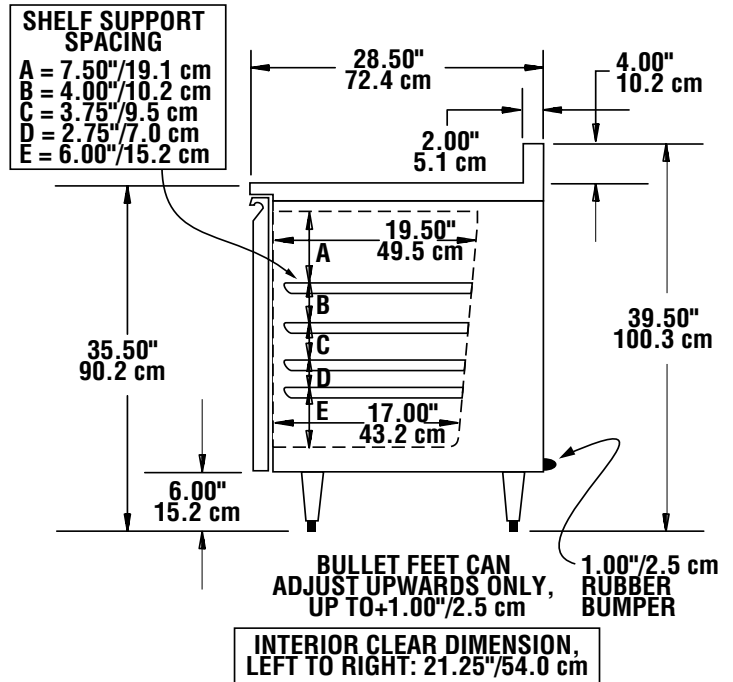
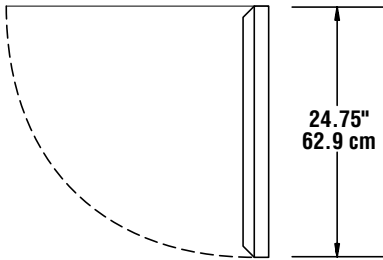

AutoCAD® library reference numbers are shown below the model numbers.

**PLAN VIEW
MODEL 402**

**ELEVATION VIEW
MODEL 402**

**RIGHT END VIEW
MODEL 402**

**STANDARD DOOR HINGING IS ON RIGHT
HINGING MAY BE REVERSED AT INSTALLATION**
**DOOR CLEARANCE DETAIL
MODEL 402**
INSTALLATION NOTE:

Refrigeration system is designed so that air will flow under the unit, through the compressor area, and out the top rear of the unit. Any restriction to this air flow path will void the warranties.

MODEL NUMBER	NUMBER OF SHELVES	SHELF AREA	STORAGE CAPACITY*	SHIP WEIGHT	HORSE-POWER	VOLTS/HERTZ/PHASE	AMPS	NEMA PLUG
402	2	7.2 ft 0.67 m	5.7 ft 0.16 m	176 lbs 80 kg	1/5	115/60/1	5.0	5-15P

