



Pizzaovens.com

1.877.FOR.OVEN
367.6836

Since 1999

DoughPro Tandoori Ovens.

Spec Sheet. For Models DPTO & DPTO28 -G(gas) -C(charcoal) (see full list p2.)

- Option of 2 Internal diameters 20" & 28".'
- Traditional Ceramic cooking surface.
- 3 standard external shapes: Round, Square and Barrel shaped.
- Finish : Stainless steel, mild steel (black std. ,
- or any color on request), or polished copper & brass.
- Fuel: Charcoal or Gas.
- Designed to meet the demands of a busy commercial
- / display kitchen.
- The first high technology tandoori; No longer is there a
- need to replace the internal pot yearly.
- Portable / Transportable between venues (option of castors)
- Guaranteed for 12 months.
- Easy Installation / Removal. Ready to operate
- no further construction work required.
- Fully insulated.
- All accessories available.
- Demonstration video available.
- Supplied with analogue thermometer.
- Used by Hilton, Intercontinental, Hyatt, Fairmont Hotels
Aman, Moevenpick, Mandarin Oriental, Sheraton,
and Marriot Hotels.
- Gas heat input 57,000 Btus 1/2" Connection required.
- Approx. Weight of 20" Tandoori 1500lbs. & 28" Tandoori 1800lbs.

GAS-FIRED
UL LISTED
COMMERCIAL COOKING
EQUIPMENT
27UT
Wood / Gas Fired Oven



DOUGHPRO TANDOORI OPTIONS *BARREL, CYLINDRICAL OR SQUARE ENCLOSURES*

FRONT VIEWS

STD. CYLINDRICAL TANDOORI 20"
CERAMIC INNER DRUM
UL/EPH COMPLIANT.
AVAILABLE IN 33.5" SQUARE
OR CYLINDRICAL ENCLOSURE
(STAINLESS OR MILD STEEL)

STD. BARREL TANDOORI 20"
CERAMIC INNER DRUM
UL/EPH COMPLIANT.

STD. BARREL TANDOORI 28"
CERAMIC INNER DRUM
UL/EPH COMPLIANT.

STD. CYLINDRICAL TANDOORI 28"
CERAMIC INNER DRUM
UL/EPH COMPLIANT.
AVAILABLE IN 41.5" SQUARE OR
OR CYLINDRICAL ENCLOSURE
(STAINLESS OR MILD STEEL)

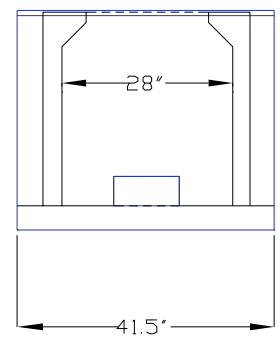
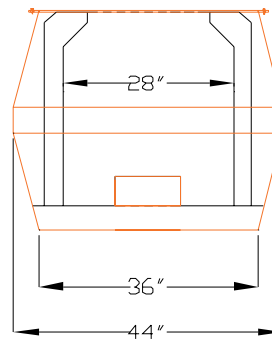
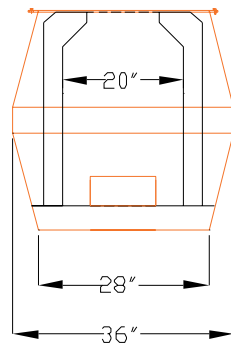
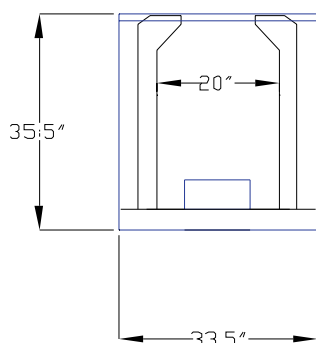

DOUGHPRO[®]

PROPROCESS CORPORATION

MODELS

Std. 20"ID

DPTO	-C-S	Tandoori Oven/Charcoal/Mild Finish/Square
DPTO	-C-R	Tandoori Oven/Charcoal/Mild Finish/Round
DPTO	-C-SS-S	Tandoori Oven/Charcoal/Stain Steel/Square
DPTO	-C-SS-R	Tandoori Oven/Charcoal/Stain Steel/Round
DPTO	-C-TC	Tandoori Oven/Charcoal/Terra Cotta Pot
DPTO	-G-S	Tandoori Oven/Gas/Mild Finish/Square
DPTO	-G-R	Tandoori Oven/Gas/Mild Finish/Round
DPTO	-G-SS-S	Tandoori Oven/Gas/Stain Steel/Square
DPTO	-G-SS-R	Tandoori Oven/Gas/Stain Steel/Round
DPTO	-G-TC	Tandoori Oven/Gas/Terra Cotta Pot

Large 28"ID

DPTO28	-C-S	Large Tandoori Oven/Charcoal/Mild Finish/Square
DPTO28	-C-R	Large Tandoori Oven/Charcoal/Mild Finish/Round
DPTO28	-C-SS-S	Large Tandoori Oven/Charcoal/Stain Steel/Square
DPTO28	-C-SS-R	Large Tandoori Oven/Charcoal/Stain Steel/Round
DPTO28	-C-TC	Large Tandoori Oven/Charcoal/Terra Cotta Pot
DPTO28	-G-S	Large Tandoori Oven/Gas/Mild Finish/Square
DPTO28	-G-R	Large Tandoori Oven/Gas/Mild Finish/Round
DPTO28	-G-SS-S	Large Tandoori Oven/Gas/Stain Steel/Square
DPTO28	-G-SS-R	Large Tandoori Oven/Gas/Stain Steel/Round
DPTO28	-G-TC	Large Tandoori Oven/Gas/Terra Cotta Pot

Gas Cover

On all gas fired Tandoori's there is a S/steel cover over the gas system/air duct. This must remain open and be accessible to maintain the appliance.

Dimensions: 8"(H) X 20"(W) X 6"(D) location 3" above floor.

Access. Allow 30" clear space to remove the gas system

Options for fitting DoughPro Tandoori into bench tops

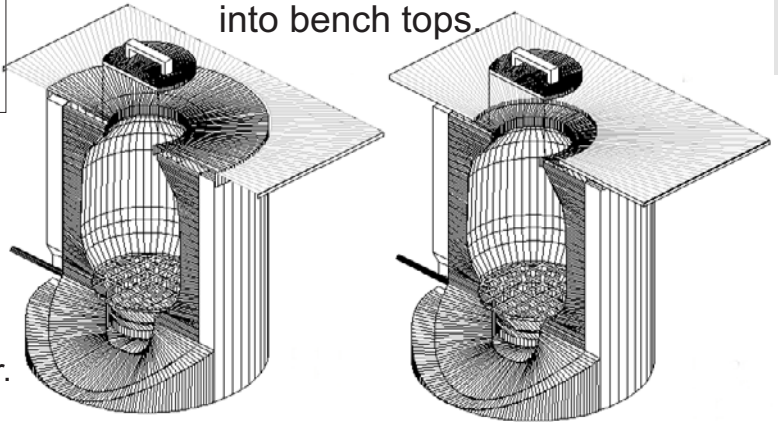

Granite benchtops should be cut to give expansion joints around oven mouth.
Contact DoughPro for advice.



Various Shapes available.
Combo units with racking and custom tops by special order.



COMMERCIAL COOKING
EQUIPMENT
27LUT
Wood / Gas Fired Oven



ANSI/UL 4