





Flatten Pizza dough like a professional... without skilled labor!

- Manually operated, no motor or compressors required.
- Produces crusts equal to hand tossed product.
- Safe to operate and clean.
- Compact size fits just about anywhere.
- Flattens all size pizzas up to and including 18" (46 cm) diameter.
- Thickness adjustment provided.
- Portions size of dough ball dictates size of crust.
- Heat potential for upper platen helps cold dough flow faster.
- Fast cleaning since no flour required.
-     Listed.



ON/OFF Switch	Yes	Electrical Data 120v/60hz 1450w/12.5amps 240v/50-60hz 1450w/6.04amps
Automatic Timer	No	
Adjustable Thickness	Yes	
Temperature Control	Yes	Shipping Weight 190 lbs. / 79 kgs.
Maximum Heat	0-200°F	

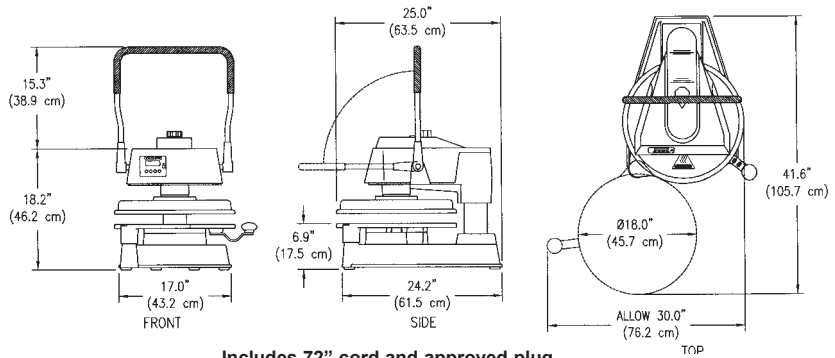

Includes 72" cord and approved plug.

Operating the DP1100 is simple, requiring only minutes of instruction:



After allowing upper platen to reach desired temperature, swing out lower platen and place pre-portioned ball of dough in approximate center and swing closed. An approved lubricant/release agent such as olive oil or DOUGHPRO's Cookware Food Release Spray # DPPC1 applied to the top of the dough ball will greatly improve the pressing operation.



Once your desired time is set, pull down on handle and hold, applying pressure. The digital control will count down. A beeping sound will be heard when it reaches 0.



Lift up handle, open platen and place flattened crust on screen, disc or pan. Now you're ready for make-up and baking.

Specifications, Details and Prices are subject to change without prior notice.



Pizzaovens.com

1.877.FOR.OVEN
367.6836

Since 1999

DOUGHPRO®
PROPROCESS CORPORATION