



Electro-Mechanical™ Automatic Dough Press

- Operation is entirely electro-mechanical which means no noisy compressors or leaky hydraulics to deal with.
- Produces crusts equal to hand tossed in about 10 seconds per crust.
- Safe to operate and clean.
- Compact size fits just about anywhere.
- Flattens all size pizzas up to and including 18" (46 cm) diameter.
- Thickness adjustment provided.
- Heat potential for upper platen helps cold dough flow faster.
-   Listed.



ON/OFF Switch	Yes	Electrical Data 120v/60hz 1450w/12.5amps 230v/50-60hz 1450w/6.0amps
Automatic Timer	Yes	
Adjustable Thickness	Yes	
Temperature Control	Yes	Shipping Weight 205 lbs. / 91 kgs.
Maximum Heat	0-200°F	

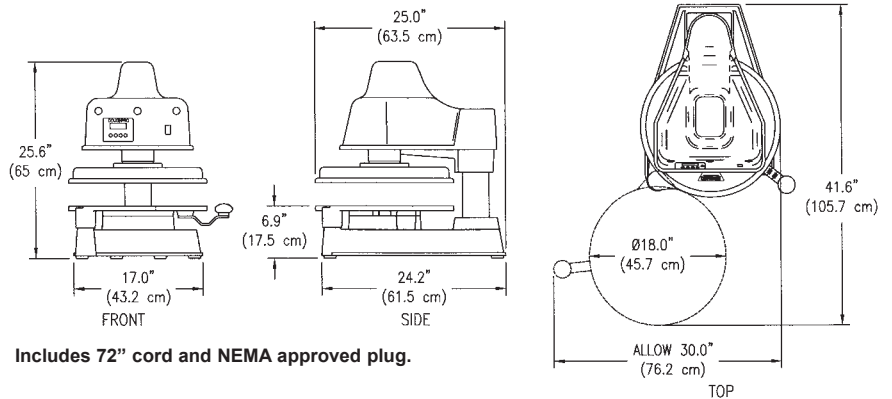

Includes 72" cord and NEMA approved plug.

Simply press two buttons and the press does the rest.



After allowing upper platen to reach desired temperature, swing out lower platen and place pre-portioned ball of dough in approximate center and swing closed. An approved lubricant/release agent such as olive oil or DOUGHPRO's Cookware Food Release Spray # DPPC1 applied to the top of the dough ball will greatly improve the pressing operation.



Set the desired time cycle. Push down both left and right piston activation buttons, hold until resistance is felt and release. A beeping sound will be heard when it reaches 0.



Wait for the automatic pressing cycle to finish. Pull out lower platen and place flattened crust on screen, disc or pan. Now you're ready for make-up and baking.

Specifications, Details and Prices are subject to change without prior notice.



Pizzaovens.com

1.877.FOR.OVEN
367.6836

Since 1999

DOUGHPRO®
PROPROCESS CORPORATION