

# TORTILLAPRO™

Model No.

# DP6208

## 8" Mini Dual Heated Platens

*The perfect way to press tortillas, thin crust pizza or a host of other items in a space of less than 1 sq. foot.*

- Manually operated, no motor or compressors required.
- Flattens all tortilla and pizza dough up to 8" diameter.
- Heat potential for upper & lower platens help cold tortilla and pizza dough flow faster.
- Perfect solution for pressing tortillas and 8" size pizza crust.
- Compact size fits anywhere.
- Easy to operate and clean.

-   Listed.



ON/OFF Switch	Yes	Electrical Data 120v/60hz 1750w/14.6amps 240v/50-60hz 2000w/8.3amps
Automatic Timer	No	
Adjustable Thickness	No	
Temperature Control	Yes	Shipping Weight's 36 lbs. / 16 kgs.
Maximum Heat	0-425°F	

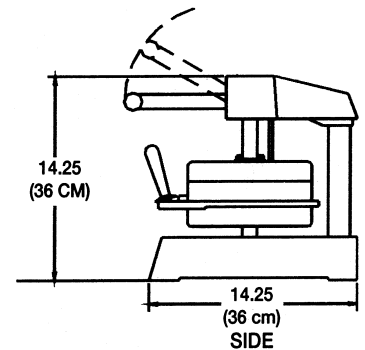
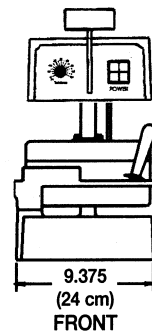

**Pressing on the DP6208 is simple, flattens tortilla or pizza dough in seconds.**



After allowing upper and lower platens to reach desired temperature, swing out lower platen and place pre-portioned ball of dough in approximate center and swing closed. An approved lubricant/release agent such as olive oil or DOUGHPRO's Cookware Food Release Spray # DPPC1 applied to the top of the dough ball will greatly improve the pressing operation.



Pull down on handle and hold for about 3-7 seconds.



Lift up handle, open platen and place flattened tortilla on a grill or if your pressing pizza dough place crust on screen, disc or pan. Now you're ready for make-up and baking.



[Pizzaovens.com](http://Pizzaovens.com)

1.877.FOR.OVEN  
367.6836

Since 1999