



**doughXpress**<sup>TM</sup>  
*The Start Of A Great Pizza!*<sup>TM</sup>

# DM-18

## ECONOMY MANUAL PIZZA PRESS

With 43 years of proven press design and manufacturing expertise, HIX Corporation introduces the efficient, economical, and durable DM-18. Discover the quick, safe way to flatten your pizza dough without the need for flour, multiple pass dough rollers, and best of all, no skilled labor.

### **FEATURES INCLUDE:**

- Heated upper platen helps dough flatten faster and easier. Can also be used heat off for cold pressing.
- Digital temperature control can be set up to 200°F and displays current reading.
- Digital timer begins automatically when the handle is lowered and resets after raised.
- Full range dough thickness adjustment up to 7/8".
- Illuminated on/off switch. The heat indicating light will go off when the set temperature is reached.
- Flattens dough balls into pizzas up to 18" in diameter.
- Appliance white finish with aluminum upper and lower platens that can be optionally non-stick coated.
- 120 volts, 7 amps, 840 watts.
- Shipping Weight 92 lbs.



**Visit [www.doughxpress.com](http://www.doughxpress.com) or Call 1-800-835-0606, ext. 205**

**HIX** CORPORATION  
*Food Equipment Division*



## DM-18 ECONOMY MANUAL PIZZA PRESS SPECIFICATIONS

### DIMENSIONS

Width: 18 inches, 45.7 centimeters  
Height: 14-7/8 inches, 37.8 centimeters  
Depth: 28-1/4 inches, 71.8 centimeters

### WEIGHT

Shipping: 92 lbs.

### ELECTRICAL

120 Volts / 60 Hz  
840 Watts  
7 Amps / Single Phase  
Standard Grounded NEMA Plug

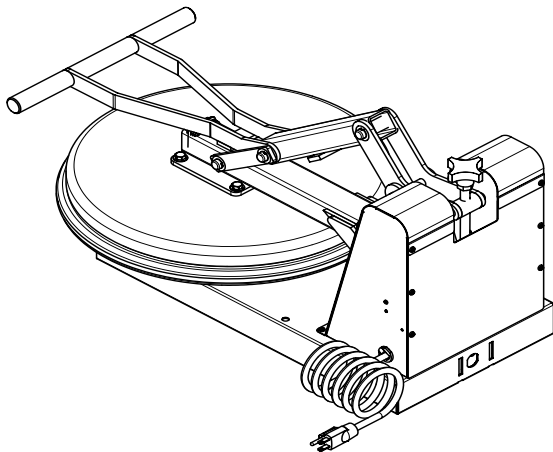
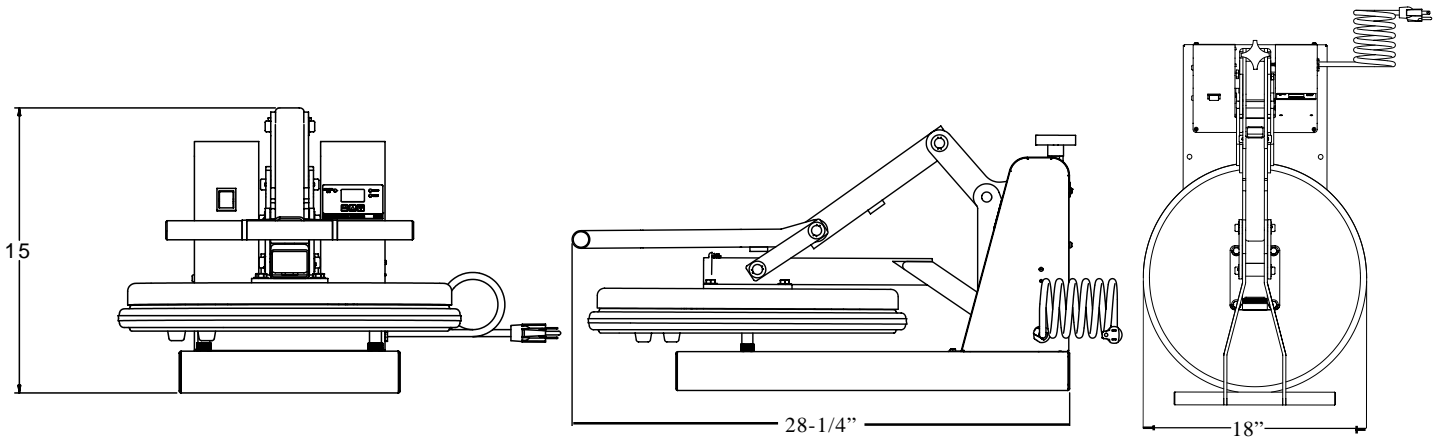

Available Through:



[Pizzaovens.com](http://Pizzaovens.com)

1.877.FOR.OVEN  
367.6836

Since 1999

**HIX** CORPORATION  
Food Equipment Division