

PIZ3 & PIZ6

“Superior *quality* product
at an *affordable* price !”



PIZ3



PIZ6

PIZ Series ovens

Doyon's PIZ series are the most advanced and productive compact pizza ovens on the market. The unique Jet Air systems help you bake 30% to 50% faster and more evenly than traditional deck ovens. These exclusive ovens occupy 40% to 50% less floor space for the same production. Preheats in 15 to 20 minutes or less at the start of the day and will bake your pizzas in 5 to 6 minutes at 460° F (238° C). The heat provided from the nickel coated perforated deck makes a nice even crust thanks to the air moving through the holes and from the heat of the metal deck itself. You can remove a product and put another one at the same place without concern about cold spots you get from traditional deck ovens. Reduce your energy costs by more than 50% compared to a deck oven. The air is recycled and the heating system will be on about 60% of the time because of its high efficiency. The PIZ series is priced at half the price of conveyor ovens. It takes less floor space, offers greater menu flexibility and higher quality baking results. The PIZ series is priced a little higher than traditional deck ovens but it makes up the difference in increased production, better performance, energy and labor savings.

JET AIR PIZZA OVENS

FEATURING

- Fast baking: 5-6 minutes at 460°F (238 °C)
- Preheats in 15 to 20 minutes. There's no need to increase the oven temperature during peak periods
- Jet Air convection oven
- Reduce your energy costs by more than 50% versus a deck oven
- Stainless steel inside and outside
- Large baking capacity (3 baking decks)
- Direct baking on nickel coated perforated decks
- PIZ3 : 5" X 30" (127mm X 762mm) door opening
- PIZ6 : 5 3/4" X 40" (146mm X 1016mm) door opening
- Full view heavy duty doors
- Easy cleaning
- Brightly lit
- 3/4 HP motor
- ETL and NSF listed
- One year parts and labor warranty

OPTIONAL

- Stand with locking casters (PIZ3B or PIZ6B)

DIMENSIONS

- PIZ3** 35 3/4"W X 40 3/4"D X 31 1/2"H
(908 mm) X (1035 mm) X (800 mm)
- PIZ6** 47 3/4"W X 43 1/2"D X 33 1/2"H
(1213 mm) X (1105 mm) X (851 mm)
- PIZ6G** 47 3/4"W X 47 3/4"D X 34 1/4"H
(1213 mm) X (1213 mm) X (870 mm)

INTERIOR DIMENSIONS

- PIZ3** 30"W X 22 1/2"D X 19"H
(762 mm) X (572 mm) X (483 mm)
- PIZ6** 39 3/4"W X 25"D X 21"H
(1010 mm) X (635 mm) X (533 mm)
- PIZ6G** 39 3/4"W X 24"D X 21"H
(1010 mm) X (610 mm) X (533 mm)

GAS SYSTEM (PIZ6G - Natural or propane)

BTU total : 70 000 BTU
 120V - 1 PH - 12 A - 1.4 kW - 2 wires - 60 Hz NEMA 5-15P
Gas inlet : 1/2" NPT
Draft hood : 4" (102 mm)

Recommended gas pressure:

Propane gas : 11" W.C.
 Natural gas : 7" W.C.

ELECTRICAL SYSTEM

- PIZ3 :**
 120/208V - 3 PH - 24 A - 8.2 kW - 4 wires - 60 Hz
 120/240V - 1 PH - 34 A - 8.2 kW - 3 wires - 60 Hz
 220V - 1 PH - 42 A - 9.2 kW - 2 wires - 50 Hz
- PIZ6:**
 120/208V - 3 PH - 43 A - 13.5 kW - 4 wires - 60 Hz
 120/240V - 1 PH - 56 A - 13.5 kW - 3 wires - 60 Hz
 220V - 1 PH - 52 A - 13.5 kW - 2 wires - 50 Hz

PRODUCTION PER HOUR(460°F/238°C - 5 min)

- | | |
|-----------------|-------------------------|
| PIZ3 | PIZ6 & PIZ6G |
| 30 - 18" Pizzas | 60 - 18" Pizzas |
| 60 - 14" Pizzas | 90 - 14" Pizzas |
| 60 - 12" Pizzas | 90 - 12" Pizzas |
| 150 - 9" Pizzas | 180 - 9" Pizzas |
| 180 - 6" Pizzas | 240 - 6" Pizzas |

SHIPPING WEIGHT

PIZ3 : 450 lbs (204 kg) approximately
 PIZ3B : 150 lbs (68 kg) approximately
 PIZ6 : 700 lbs (318 kg) approximately
 PIZ6G : 820 lbs (372 kg) approximately
 PIZ6B : 135 lbs (61 kg) approximately

Electrical inlet located at the back of the unit.
 Specifications and design subject to change without notice.

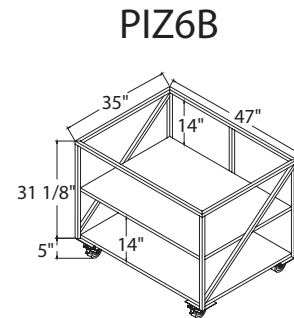
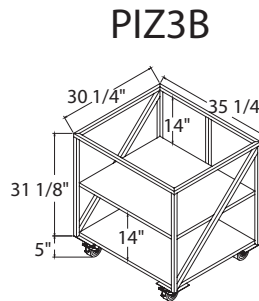
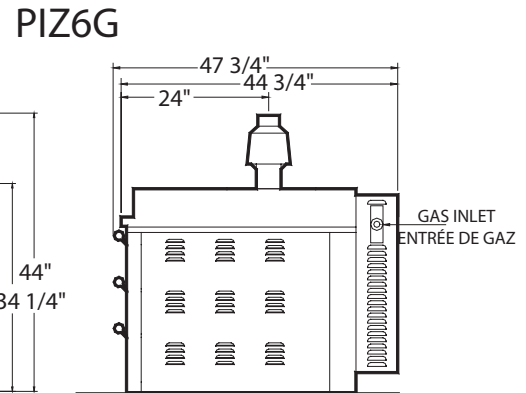
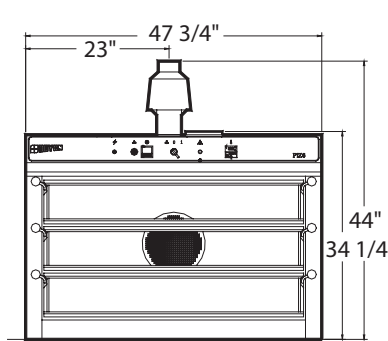
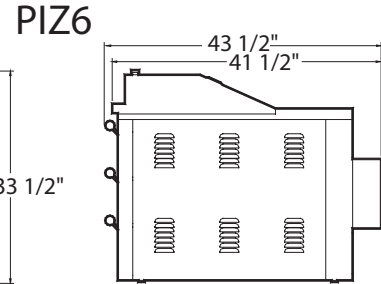
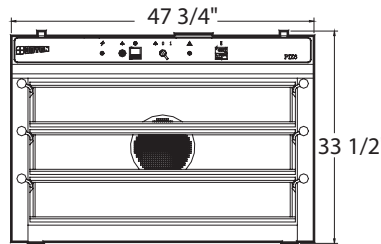
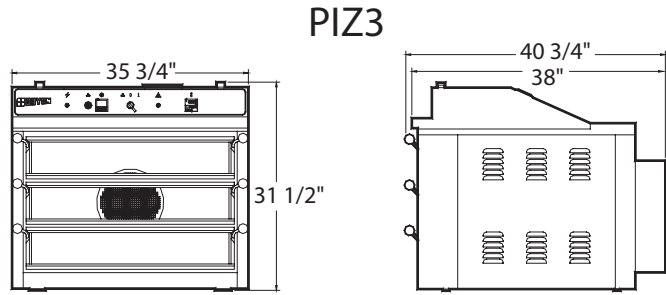

Your local distributor:

Pizzaovens.com

1.877.FOR.OVEN
367.6836

Since 1999