



Pizzaovens.com

1.877.FOR.OVEN
367.6836

Since 1999

Spiral Mixers with hydraulic lift



Mixer control



Lifting control

"Superior *quality* product
at an *affordable* price!"

Spiral mixers FEATURING

- Available in right lifting (ABDXXX) or left lifting (ABEXXX) versions
- Simple to use manual or automatic digital control
- 9 personalized programs, enables inexperienced labor to operate the units
- Digital display of mixing time
- Unique stainless steel bowl with a high center that eliminates dough feeder post
- 3 to 10 minutes mixing time, depending on type of dough
- Keep dough cooler for longer yeast viability and better gluten development
- Increase volume
- Scientifically designed spiral hook for maximum efficiency
- Spiral mixers have 2 speeds for higher efficiency
- 3 powerful independent heavy duty motors; one for the bowl, one for the hook and one for the hydraulic system
- See-through bowl guard with safety interlock. Prevents operation when guard is open
- Safety guard, bowl and mixing tools are stainless steel
- Virtually maintenance free, extremely durable
- Even the smallest batches can be made in our large spiral mixer (see chart on back)
- Superior torque transmission which eliminates vibration and noise for heavy loads
- Metal-rubber composite gear type belt, non-slipping
- Heavy duty frame with lead-free enamel coating for easy cleaning
- Motor overload protection
- Hydraulic jack equipped with a safety valve in case of loss of pressure
- ETL & ETL Sanitation listed
- One year parts and labor limited warranty

ABD & ABE Series spiral mixers

Proper oxygenation, rotational speed, synchronisation of bowl and hook as well as time are crucial for making perfect dough. That is why the award winning Doyon spiral mixer will beat the competition everytime in making the finest quality dough. Great for breads, bagels, pizza and gentle french type dough. Our spiral mixers will significantly reduce your operating time.

OPTIONAL

- Integrated water meter with automatic dosing up to 99.9 liters

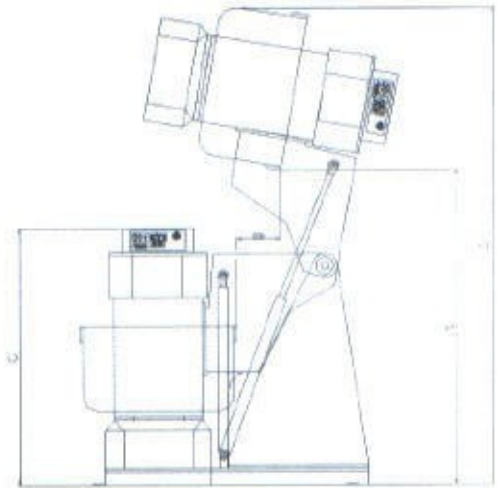
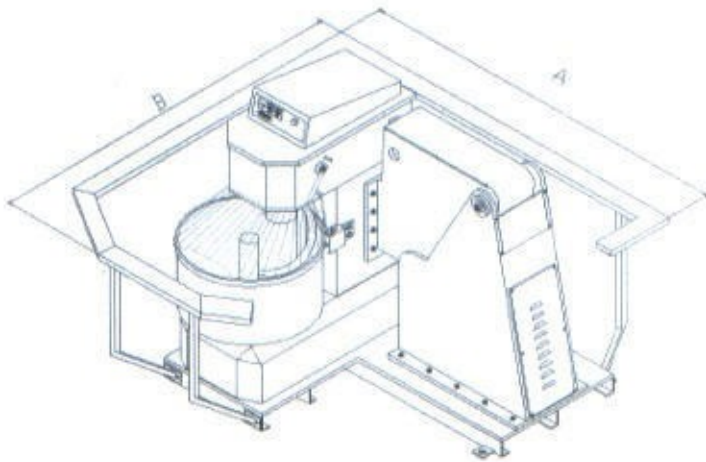

| MODEL (CODE) | Quarts | A | B | C | D | E | FLOUR CAPACITY | | DOUGH CAPACITY (60 % A.R.) | | SHIPPING WEIGHT |
|---------------------------|--------|----------------|--------------------|--------------------|---------------------|--------------------|----------------|------------------|-------------------------------|------------------|--------------------|
| | | | | | | | min | max | min | max | |
| Dropping on table | | | | | | | | | | | |
| ABX480 (AB080) | 175 | 70" 1780 mm | 70" 1780 mm | 61 1/4" 1550 mm | 98 1/2" 2500 mm | 55 1/4" 1400 mm | 11 lb 5 kg | 176 lb 80 kg | 18 lb 8 kg | 280 lb 125 kg | 2425 lb 1100 kg |
| ABX410 (AB100) | 225 | 70" 1780 mm | 70" 1780 mm | 61 1/4" 1550 mm | 98 1/2" 2500 mm | 55 1/4" 1400 mm | 22 lb 10 kg | 221 lb 100 kg | 35 lb 16 kg | 350 lb 160 kg | 2645 lb 1200 kg |
| ABX420 (AB120) | 250 | 70" 1780 mm | 70" 1780 mm | 61 1/4" 1550 mm | 98 1/2" 2500 mm | 55 1/4" 1400 mm | 22 lb 10 kg | 265 lb 120 kg | 35 lb 16 kg | 425 lb 190 kg | 2865 lb 1300 kg |
| ABX490 (AB150) | 300 | 70" 1780 mm | 70" 1780 mm | 61 1/4" 1550 mm | 98 1/2" 2500 mm | 55 1/4" 1400 mm | 22 lb 10 kg | 330 lb 150 kg | 35 lb 16 kg | 520 lb 235 kg | 3200 lb 1450 kg |
| Dropping in hopper | | | | | | | | | | | |
| ABX880 (AB080) | 175 | 78" 1980 mm | 70" 1780 mm | 61 1/4" 1550 mm | 114 1/2" 2900 mm | 71" 1800 mm | 11 lb 5 kg | 176 lb 80 kg | 18 lb 8 kg | 280 lb 125 kg | 2535 lb 1150 kg |
| ABX810 (AB100) | 225 | 78" 1980 mm | 72 1/2" 1840 mm | 61 1/4" 1550 mm | 114 1/2" 2900 mm | 71" 1800 mm | 22 lb 10 kg | 221 lb 100 kg | 35 lb 16 kg | 350 lb 160 kg | 2755 lb 1250 kg |
| ABX820 (AB120) | 250 | 78" 1980 mm | 72 1/2" 1840 mm | 61 1/4" 1550 mm | 114 1/2" 2900 mm | 71" 1800 mm | 22 lb 10 kg | 265 lb 120 kg | 35 lb 16 kg | 425 lb 190 kg | 2975 lb 1350 kg |
| ABX890 (AB150) | 300 | 78" 1980 mm | 75 1/2" 1920 mm | 63" 1600 mm | 116 1/4" 2950 mm | 71" 1800 mm | 22 lb 10 kg | 330 lb 150 kg | 35 lb 16 kg | 520 lb 235 kg | 3200 lb 1450 kg |

Note: Replace 'X' in model by D for right lifting model or E for left lifting model

ELECTRICAL SYSTEM

208-240V 32A 3PH NEMA 15-50P

Hook motor : 10 HP

Bowl motor : 2 HP

Hydraulic motor : 2 HP

Specifications and design subject to change without notice.