



Spiral Mixers

“Superior quality product at an affordable price !”



AEF015



AEF035 AEF050
AEF080 AEF100
AEF120

Spiral mixers FEATURING

- Simple to use manual or automatic digital control (except AEF015, manual only)
- 50 personalized programs, enables inexperienced labor to operate the units (except AEF015)
- Digital display of mixing time
- Unique stainless steel bowl with a high center that eliminates dough feeder post
- 3-10 minutes mixing time, depending on type of dough
- Keep dough cooler for longer yeast viability and better gluten development
- Increase volume
- Scientifically designed spiral hook for maximum efficiency
- Spiral mixers have 2 speeds for higher efficiency
- 2 powerful independent heavy duty motors, one for the bowl and one for the hook (except AEF015)
- See-through bowl guard with safety interlock. Prevents operation when guard is open
- Safety guard, bowl and mixing tools are stainless steel
- Virtually maintenance free, extremely durable
- Even the smallest batches can be made in our large spiral mixer (see chart on back)
- Superior torque transmission which eliminates vibration and noise for heavy loads
- Metal-rubber composite gear type belt, non-slipping
- Heavy duty frame with lead-free enamel coating for easy cleaning
- Mounted on casters for greater mobility
- Quick locking device to secure mixer in place when mixing
- Motor overload protection
- ETL & ETL sanitation approved
- One year parts and labor limited warranty

OPTIONAL

- Spiral mixer with lifter/dumper

AEF Series spiral mixers

Proper oxygenation, rotational speed, synchronisation of bowl and hook as well as time are crucial for making perfect dough. That is why the award winning Doyon spiral mixer will beat the competition everytime in making the finest quality dough. Great for breads, bagels, pizza and gentle french type dough. Our spiral mixers will significantly reduce your operating time.

DIMENSIONS

AEF015	16"W (40.6 cm)	X 29"D (73.7 cm)	X 38 3/4"H (98.4 cm)
AEF035	21 1/2"W (54.6 cm)	X 41"D (104.1 cm)	X 46 1/4"H (117.5 cm)
AEF050	26 1/4"W (66.7 cm)	X 46 1/2"D (118.1 cm)	X 51 3/8"H (130.5 cm)
AEF080	31"W (78.7 cm)	X 60 1/4"D (153 cm)	X 54"H (137.2 cm)
AEF100	34 1/4"W (87 cm)	X 63 5/8"D (161.6 cm)	X 54"H (137.2 cm)
AEF120	34 1/4"W (87 cm)	X 63 5/8"D (161.6 cm)	X 54"H (137.2 cm)

ELECTRICAL SYSTEM

AEF015 : 2HP	208-240V 6A	3PH NEMA L15-20P
AEF035 : 3HP & 1HP	208-240V 14A	3PH NEMA L15-20P
AEF050 : 7HP & 1.5HP	208-240V 20A	3PH NEMA 15-30P
AEF080 : 10HP & 2HP	208-240V 32A	3PH NEMA 15-50P
AEF100 : 10HP & 2HP	208-240V 32A	3PH NEMA 15-50P
AEF120 : 10HP & 2HP	208-240V 32A	3PH NEMA 15-50P

CAPACITY (Flour)

	MIN	MAX
AEF015	2 lbs (1 kg)	30 lbs (15 kg)
AEF035	5 lbs (2 kg)	75 lbs (35 kg)
AEF050	7 lbs (3 kg)	110 lbs (50 kg)
AEF080	11 lbs (5 kg)	175 lbs (80 kg)
AEF100	22 lbs (10 kg)	220 lbs (100 kg)
AEF120	22 lbs (10 kg)	260 lbs (120 kg)

CAPACITY (Dough : 60% absorption ratio)

	MIN	MAX
AEF015	3 lbs (1.5 kg)	50 lbs (25 kg)
AEF035	8 lbs (3.5 kg)	120 lbs (55 kg)
AEF050	12 lbs (5.5 kg)	175 lbs (80 kg)
AEF080	18 lbs (8 kg)	280 lbs (125 kg)
AEF100	35 lbs (16 kg)	350 lbs (160 kg)
AEF120	35 lbs (16 kg)	425 lbs (190 kg)

BOWL CAPACITY SHIPPING WEIGHT

	Quarts (liters)	
AEF015	30	540 lbs (245 kg)
AEF035	70	980 lbs (445 kg)
AEF050	100	1200 lbs (545 kg)
AEF080	175	1640 lbs (745 kg)
AEF100	225	1750 lbs (795 kg)
AEF120	250	1870 lbs (849 kg)

AEF015

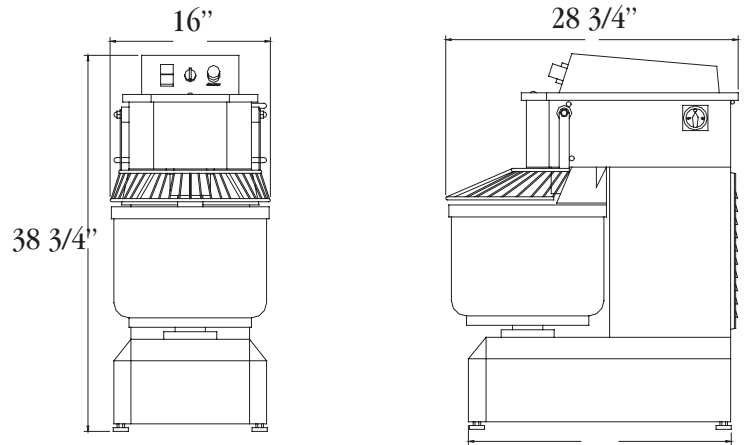

AEF035, AEF050, AEF080, AEF100 & AEF120

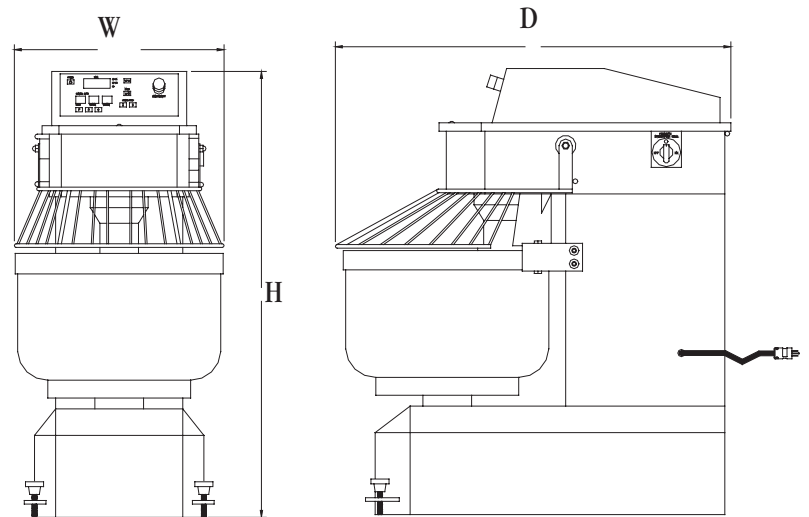

Specifications and design subject to change without notice.



Your local distributor: / Votre distributeur:

