



AEF050



AEF050I

AEF Series spiral mixers

Proper oxygenation, rotational speed, synchronisation of bowl and hook as well as time are crucial for making perfect dough. That is why the award winning Doyon spiral mixer will beat the competition everytime in making the finest quality dough. Great for breads, bagels, pizza and gentle french type dough. Our spiral mixers will significantly reduce your operating time.

AEF

“Superior *quality* product
at an *affordable* price !”

Spiral mixers

Standard Features

- Simple to use manual or automatic digital control
- 9 personalized programs, enables inexperienced labor to operate the units
- Digital display of mixing time
- Unique stainless steel bowl with a high center that eliminates dough feeder post
- 3-10 minutes mixing time, depending on type of dough
- Keep dough cooler for longer yeast viability and better gluten development
- Increase volume
- Scientifically designed spiral hook for maximum efficiency
- Spiral mixers have 2 speeds for higher efficiency
- 2 powerful independent heavy duty motors, one for the bowl and one for the hook (except AEF015SP & AEF025SP)
- See-through bowl guard with safety interlock. Prevents operation when guard is open
- Safety guard, bowl and mixing tools are stainless steel
- Virtually maintenance free, extremely durable
- Even the smallest batches can be made in our large spiral mixer (see chart on back)
- Superior torque transmission which eliminates vibration and noise for heavy loads
- Metal-rubber composite gear type belt, non-slipping
- Heavy duty frame with lead-free enamel coating for easy cleaning
- Mounted on casters for greater mobility
- Quick locking device to secure mixer in place when mixing
- Motor overload protection
- ETL & ETL sanitation listed
- One year parts and labor limited warranty

Optional

- Integrated water meter (AEF050 and up)
- Stainless steel construction (AEF015SPI, AEF025SPI, AEF035SPI, AEF035I, AEF050I, AEF080I, AEF100I & AEF150I)

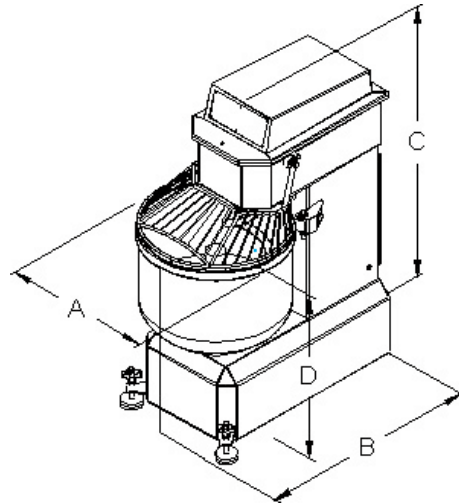

Model	Dimensions				Electrical system				Bowl speed (RPM)		Hook speed (RPM)	
	A	B	C	D	Motor (HP)	V	Ph	Nema	1st	2nd	1st	2nd
AEF015SP	17 1/4" (435 mm)	29 1/4" (740 mm)	39 3/4" (1010 mm)	22 1/4" (565 mm)	2	208-240	1	6-15P	9	18	119	238
AEF025SP	18 7/8" (480 mm)	32 3/4" (830 mm)	42 1/4" (1070 mm)	25 3/4" (654 mm)	4	208-240	1	-	9	18	119	238
AEF035SP	21 3/4" (550 mm)	41 1/4" (1045 mm)	46 7/8" (1190 mm)	27 1/2" (699 mm)	4 & 1	208-240	1	-	9.5	18	80	160
AEF035	21 3/4" (550 mm)	41 1/4" (1045 mm)	46 7/8" (1190 mm)	27 1/2" (699 mm)	3 & 1	208-240	3	L15-20P	11	22	96	192
AEF050	26 5/8" (675 mm)	47 1/4" (1200 mm)	53 3/4" (1365 mm)	28 1/2" (724 mm)	7 & 1.5	208-240	3	15-30P	10	20	86	172
AEF080	31" (785 mm)	58 1/4" (1480 mm)	56 3/4" (1440 mm)	30 1/2" (775 mm)	10 & 2	208-240	3	15-30P	10	20	86	172
AEF100	34 1/4" (870 mm)	61 3/4" (1565 mm)	56 3/4" (1440 mm)	30 1/2" (775 mm)	10 & 2	208-240	3	15-30P	10	20	86	172
AEF150	38 5/8" (980 mm)	66" (1675 mm)	58 3/4" (1490 mm)	30 1/2" (775 mm)	10 & 2	208-240	3	15-30P	8	16	91	182

Model	Bowl capacity quarts (liters)	Flour capacity lb (kg)		Dough capacity lb (kg) (60% Absorption ratio)		Shipping weight lb (kg)
		Min	Max	Min	Max	
AEF015SP	30	2 (1)	30 (15)	3 (1.5)	50 (25)	540 (245)
AEF025SP	50	5 (2)	55 (25)	8 (3.5)	88 (40)	980 (445)
AEF035SP	70	5 (2)	75 (35)	8 (3.5)	120 (55)	980 (445)
AEF035	70	5 (2)	75 (35)	8 (3.5)	120 (55)	980 (445)
AEF050	100	7 (3)	110 (50)	12 (5.5)	175 (80)	1300 (570)
AEF080	175	11 (5)	175 (80)	18 (8)	280 (125)	1810 (822)
AEF100	225	22 (10)	220 (100)	35 (16)	350 (160)	1750 (795)
AEF150	345	22 (10)	330 (150)	35 (16)	520 (235)	1990 (903)

Specifications and design subject to change without notice.



Conforms to ANSI/UL 763
Certified to CSA C22.2 no. 1335.2.14

Your local distributor:



Pizzaovens.com

1.877.FOR.OVEN
367.6836

Since 1999