



LSA616



LMA624



LMA624I

Reversible sheeters

Doyon reversible dough sheeters are designed for hotels, restaurants, pastry shops and small to high production bakeries. These sheeters are suitable for sheeting and stretching any kind of dough: yeast, croissants, puffed pastries, danish, flaky pastries, savory dough, soft pastry dough as well as stiff pizza or other kinds of dough to the required thickness. These sheeters are designed to ensure the highest degree of performance and efficiency you expect from Doyon.

LSA & LMA

“Superior *quality* product
at an *affordable* price !”

Reversible sheeters FEATURING

- Exceptional fold free reversible sheeting action
- Unique 20 digital variable speed control for the speed you really want
- Handy adjustable roller gap : from 1/32” to 1 1/2” (1-40 mm) thickness
- LMA : capacity of up to 30 pounds (14 kg) of dough
- LSA: capacity of up to 22 pounds (10 kg) of dough
- Forward reverse action is controlled by foot switch (LMA) as well as hand controls
- Polyurethane belt
- 1 HP motor with V belt transmission
- Stainless steel protective guard on each side of rollers
- Fold-up conveyors for compact storage and easy cleaning
- Stainless steel rollers help prevent sticking
- Fast roller adjustments
- Both tables have perfectly synchronized drives. The exit conveyor is faster than entry to avoid possible dough obstruction and automatically prevents tearing of delicate dough
- 2 catch pans, one on each end
- High resistance lead-free enamel coating
- Easily removable and replaceable high efficiency dough scrapers
- Virtually maintenance free, extremely durable
- Flour reservoir above rollers
- CE & ETL listed
- One year parts and labor limited warranty

OPTIONAL

- Croissant cutter for LMA630 sheeter
- Stainless steel construction sheeters (LSA616I, LSA620I, LMA620I, LMA624I, LMA630I)
- Stainless steel marine IP44 construction sheeters (LSA616M, LMA624M, LMA630M)
- Stainless steel table for LSA series sheeters

DIMENSIONS

LSA616	75 1/2"W	X 41 1/2"D	X 32"H
	(1920 mm)	X 1055 mm	X 813 mm)
LSA620	91 1/4"W	X 41 1/2"D	X 32"H
	(2320 mm)	X 1055 mm	X 813 mm)
LMA620	91 1/4"W	X 39 1/2"D	X 45 3/4"H
	(2320 mm)	X 1005 mm	X 1160 mm)
LMA624	107"W	X 39 1/2"D	X 45 3/4"H
	(2720 mm)	X 1005 mm	X 1160 mm)
LMA630	108 3/4"W	X 39 1/2"D	X 45 3/4"H
	(2760 mm)	X 1005 mm	X 1160 mm)

CONVEYOR DIMENSIONS

LSA616	19"W	X 63"L
	(483 mm)	X 1600 mm)
LSA620	19"W	X 78 3/4"L
	(483 mm)	X 2000 mm)
LMA620	23"W	X 78 3/4"L
	(584 mm)	X 2000 mm)
LMA624	23"W	X 94 1/2"L
	(584 mm)	X 2400 mm)
LMA630	23"W	X 118 1/8"L
	(584 mm)	X 3000 mm)

ELECTRICAL SYSTEM

LSA616 :	120V	4A	1PH	NEMA 5-15P
LSA620 :	120V	4A	1PH	NEMA 5-15P
LMA620 :	120V	4A	1PH	NEMA 5-15P
LMA624 :	120V	4A	1PH	NEMA 5-15P
LMA630 :	120V	4A	1PH	NEMA 5-15P

SHIPPING WEIGHT

LSA616	525 lb (238 kg)	approximately
LSA620	525 lb (238 kg)	approximately
LMA620	750 lb (341 kg)	approximately
LMA624	750 lb (341 kg)	approximately
LMA630	750 lb (341 kg)	approximately

Specifications and design subject to change without notice.

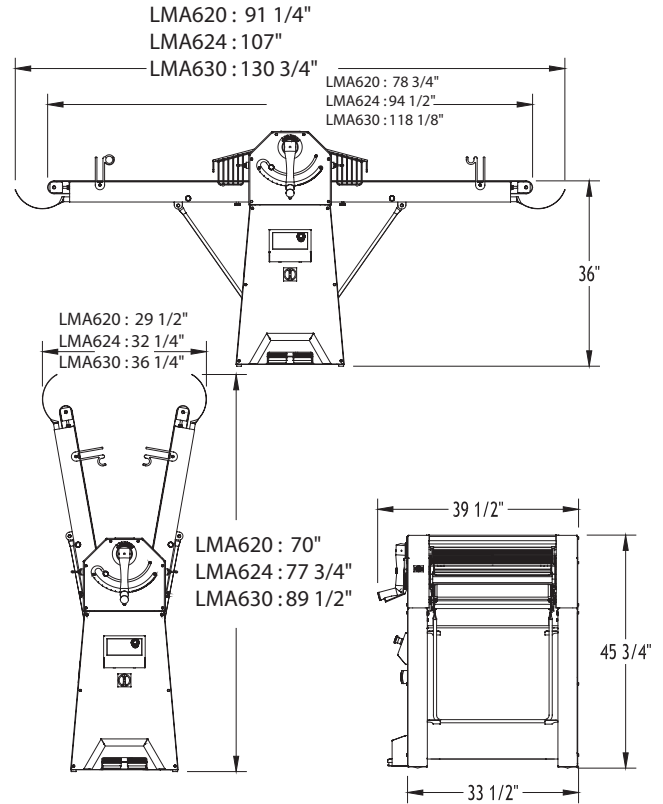
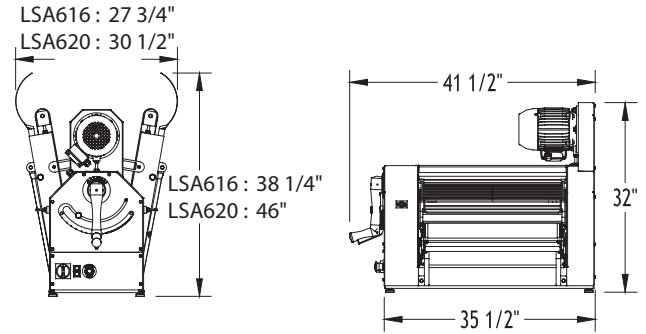
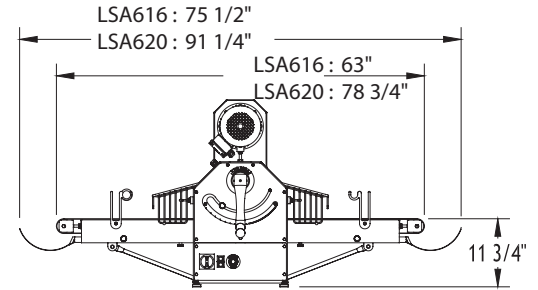

Your local distributor: / Votre distributeur:

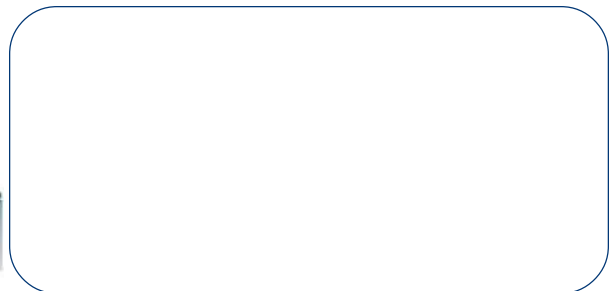

Pizzaovens.com

1.877.FOR.OVEN
367.6836

Since 1999