



Pizzaovens.com

1.877.FOR.OVEN  
367.6836

Since 1999

**E30MNG-1 E30MLP-1**  
**E30MNG-2 E30MLP-2**  
**E30MNG-3 E30MLP-3**

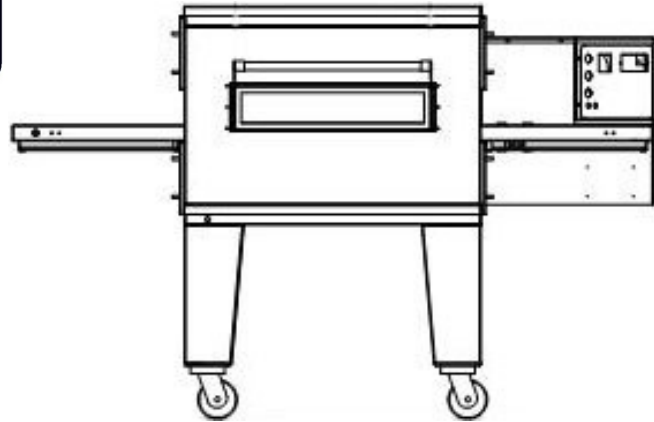

### GENERAL INFORMATION:

EDGE 30 Conveyor ovens are designed to be stacked up to three high. Each oven has a 18" wide conveyor belt and a 30" long baking chamber. These ovens can usually be installed under a standard 48" make line hood.

### STANDARD FEATURES:

- **AFFORDABLE:** EDGE30 ovens are affordably priced with an initial acquisition cost not much higher than a good quality reconditioned oven.
- **ENERGY EFFICIENT:** EDGE30 ovens use a modulating burner that modulates both gas and combustion air. This system allows for the lowest overall operating costs of any conveyor oven in its class.
- **LOW OPERATING COSTS:** Overall operating costs of the EDGE30 oven is about **35 cents per hour** based on an oven temperature of 475 deg F, electricity costs at 10 cents per kwh, and natural gas costs at \$1.30 per Ccf.
- **REMOVABLE CONTROL CABINET:** EDGE30 control cabinet houses all the electrical and gas components except for the main motor. The control cabinet can be unbolted and returned to the factory for service or upgrades. An additional control can may be used as a spare to eliminate any costly down time.
- **CONSTRUCTION:** EDGE30 ovens are manufactured to exacting tolerances and use stainless steel inside and out.
- **WARRANTY:** EDGE30 ovens come with a detailed Two Year Parts and Labor Warranty.
- **VENTALATION:** EDGE30 ovens must be used under a ventilation hood only. Hood system must conform to all local and applicable codes.
- **MANUFACTURING:** EDGE30 ovens are manufactured in our Dunbar, PA facility





CUSTOMER \_\_\_\_\_

JOB NUMBER \_\_\_\_\_



**E30MNG-1 E30MLP-1**  
**E30MNG-2 E30MLP-2**  
**E30MNG-3 E30MLP-3**

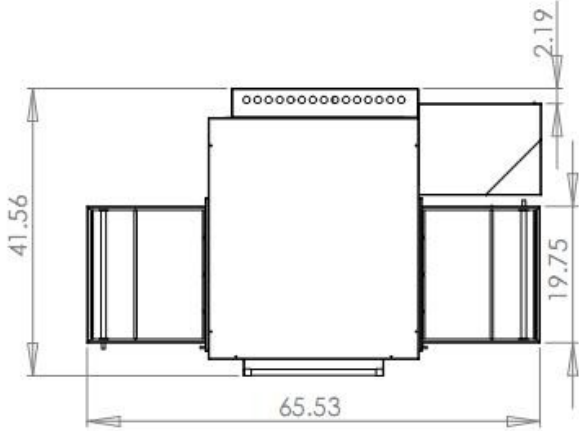

TOP VIEW

**EDGE30 TOP VIEW**

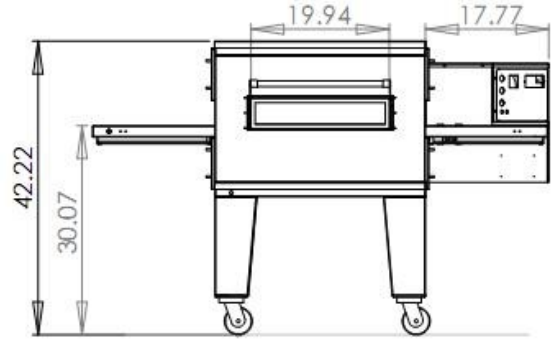

FRONT VIEW

**EDGE30 SINGLE**

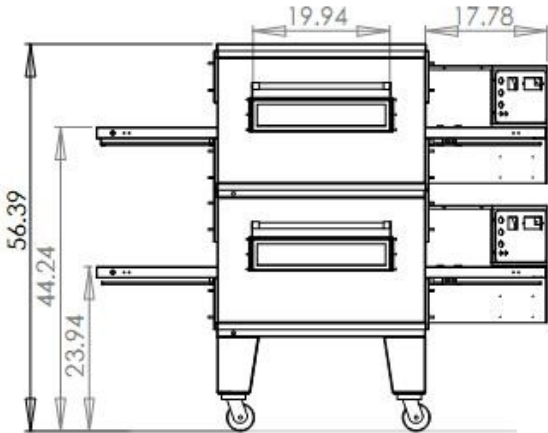

FRONT VIEW

**EDGE30 DOUBLE**

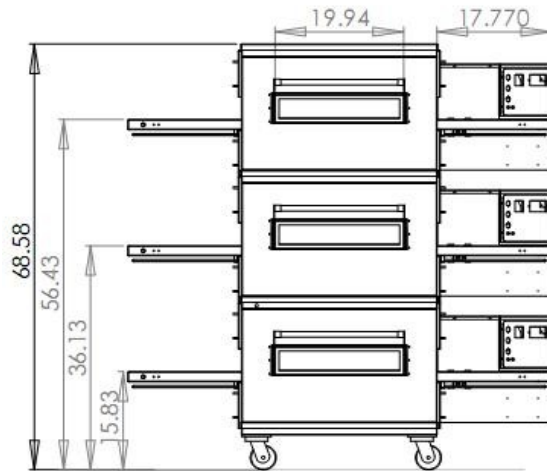

FRONT VIEW

**EDGE30 TRIPLE**

GAS TYPE	VOLTS	FREQUENCY	AMPS	SUPPLY PRESSURE	MANIFOLD PRESSURE
NATURAL	120	60 Hz	5.5	7"— 11" WC	6" WC
PROPANE	120	60Hz	5.5	10"— 13" WC	10" WC



**Pizzaovens.com**

1.877.FOR.OVEN  
367.6836

Since 1999