



air-o-convect Gas Hybrid Convection Oven 102

ITEM # _____
 MODEL # _____
 PROJECT NAME # _____
 SIS # _____
 AIA # _____



* Base not included

air-o-convect Gas Hybrid Convection Oven 102

269553 (AOS102GCP1) Gas Hybrid Convection Oven 102
 120 V/1ph/60Hz - 9A

Short Form Specification

Item No. _____

Unit to be Electrolux air-o-convect Hybrid Convection Oven. air-o-convect performs all of the functions of a convection oven and has a boilerless steaming function to add and retain moisture for high quality, consistent cooking cycles. Cooking modes include a convection (hot air) cycle (77 °F-572 °F) with an automatic moistener with 11 settings from zero to high moisture, double step cooking process, automatic pre-heating, a hold function and automatic rapid cooling. All 304 Stainless steel construction, seamless hygienic cooking chamber with all rounded corners. Double thermo-glazed door with open frame construction for cool outside door panel. IPX5 (NEMA 4) spray water protection certification. air-o-clean, automatic and built-in self cleaning system.

Gas burner is certified by Gastec for high efficiency and low emissions. EKIS pc-controlled HACCP monitoring software package available at additional cost.

Half day chef training included.

Covered by Electrolux Platinum Star™ Service Program, two-year parts and one-year labor warranty, installation start-up and performance check-up after one year from installation.



Main features

- Dry hot convection cycle (77 °F-572 °F) ideal for low humidity baking.
- Automatic moistener (11 settings) for boilerless steam generation.
 - 0 = no additional moisture
 - 1-2 = low moisture (stewed vegetables)
 - 3-4 = medium low moisture (au gratin vegetables, roasted meat and fish)
 - 5-6 = medium moisture (small portions of meat and fish)
 - 7-8 = medium-high moisture (large pieces of red meat)
 - 9-10 = high moisture (large pieces of white meat, baking and rethermalization of pre-cooked food)
- Double step cooking (first phase with moisture, second phase dry for browning).
- Core temperature probe.
- Variable fan speed (radial fan). Pulse ventilation for baking and low temperature cooking.
- Hold function for keeping food warm at the end of a cycle.
- Exhaust valve electronically controlled to extract excess humidity.
- Automatic and manual rapid cooling activation when going from a higher to a lower temperature.
- air-o-clean, automatic and built-in self cleaning system.
- Gas burner is certified by Gastec for high efficiency and low emissions.
- Ready for EKIS software (pc-based HACCP monitoring package).
- Ready for HACCP monitoring via printer.
- Electrolux Platinum Star™ service package included:
 - 2-year parts, 1-year labor warranty.
 - Start-up installation check.
 - Equipment check-up after 12 months from installation.
 - Half day chef training session.

Construction

- IPX5 (NEMA 4) spray water protection certification for easy cleaning.
- All 304 Stainless steel construction.
- Seamless hygienic cooking chamber with all rounded corners for easy cleaning.
- Double thermo-glazed door with open frame construction for cool outside door panel.
- Swing hinged easy release inner glass on door for easy cleaning.
- Swing hinged front panel for easy service access to main components.

Included Accessories

- 5 Stainless steel full-size grids (21" × 26") PNC 922076

Optional Accessories

- Open base stand PNC 922198
- Trolley for Rack Cassette PNC 922042
- Increased pitch rack cassette (8 racks) PNC 922045
- Wheels kit for rack cassette PNC 922073
- Roll-in rack support PNC 922047
- 51 plate rack PNC 922052
- Thermal blanket for banqueting rack PNC 922048
- Pair of chicken racks (8 chickens per rack) PNC 922036
- Non-stick universal pans PNC 922090-2
- Combi oven grill PNC 922093
- 4 castors (2 with brake) PNC 922003
- Fat Filters PNC 922178
- Heat Shield for 102 PNC 922252
- HACCP printer PNC 880048
- Frying Griddle PNC 922215
- Pair of Frying Baskets PNC 922239
- Stacking kit 61 on top of 102 Gas PNC 922222
- Stacking kit 62 on top of 62 or 102 Gas PNC 922268

Approval: _____

Front View

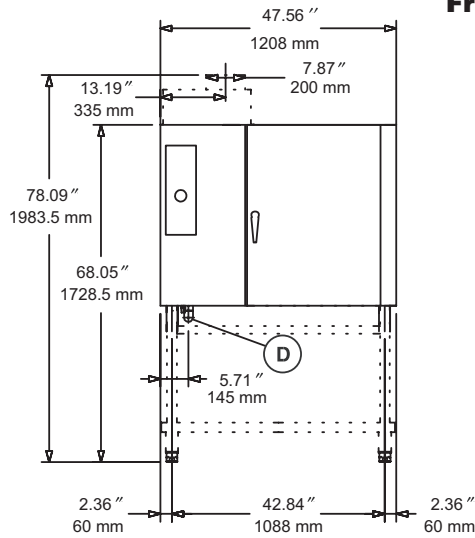

Side View

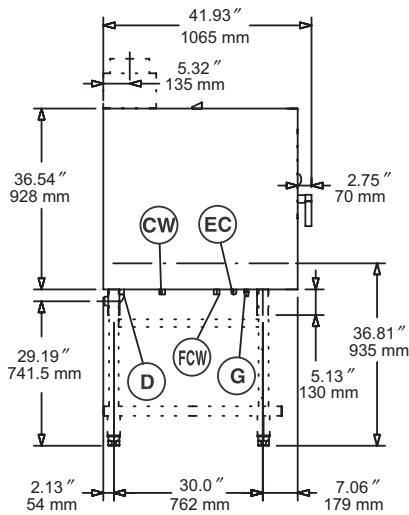

- EC = Electrical connection
- G = Gas connection
- D = Water drain
- CW = Cold Water inlet
- FCW = Filtered Cold Water inlet

Top View

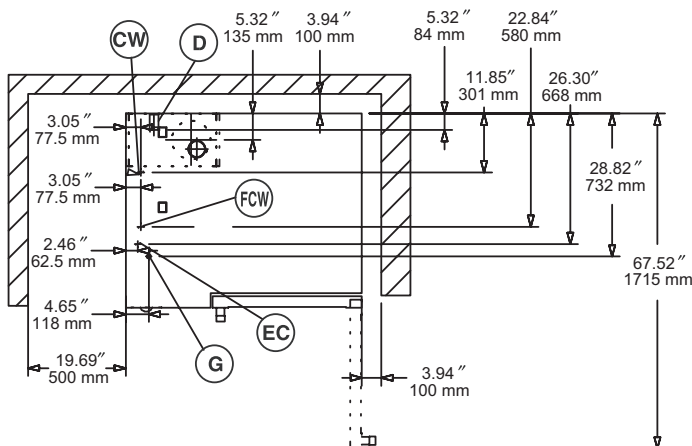

Electric

Supply voltage:
269553 (AOS102GCP1) 120 V/1ph/60Hz - 9A
Circuit breaker required

Gas (Natural or LPG)

Gas (Natural or LPG)
ISO 7/1 Gas connection diameter: ½" M
Gas regulator recommended. Supplied by others.

Max rated thermal load:

Natural Gas

Pressure: 7" w.c. (17.4 mbar)
Heating elements: 105,871 BTU (31 kW)
Total thermal load: 105,871 BTU (31 kW)

LPG

Pressure: 11" w.c. (27.4 mbar)
Heating elements: 95,625 BTU (28 kW)
Total thermal load: 95,625 BTU (28 kW)

Water

Water Consumption (gal./hr.): Min: 0.09 Max: 2.77

Water inlet "CW" – ¾" connection:

Total hardness: 5-50 ppm
Pressure: 22-36 psi (150-250 kPa)

Drain "D" 1-1/4" connection

Electrolux recommends the use of treated water, based on testing of specific water conditions.

Please refer to user manual for detailed water quality information.

Installation

Clearance: 2" (5 cm) rear and right hand sides.

Suggested clearance for service access: 20" (50 cm) left hand side.

Capacity

Sheet pans: 10 – 18" x 26"

Steam pans: 20 – 12" x 20"

Half size sheet pans: 20 – 13" x 18"

GN: 20 – 1/1 containers

10 – 2/1 containers

Max load capacity: 180 lbs. (80 kg)

Key Information

Net weight: 503 lbs (229 kg)
Shipping weight: 537 lbs (244 kg)
Shipping width: 50" (1270 mm)
Shipping height: 52-3/8" (1330 mm)
Shipping depth: 44-7/8" (1140 mm)
Shipping Volume: 68.15 cu. ft. (1.93 m³)