



Pyro Deck Gas Pizza/Baking Oven



Pyro Deck Gas Pizza/Baking Oven

Models:

GPD48

GPD48-2

GPD60

GPD60-2



*Model GPD60
(shown with optional
stainless steel legs)*

Standard Features:

- 1½" (38mm) thick Pyrorock Hearth
- 122,000 BTU (35.7 kW) input - GPD60 96,000 BTU (28.1 kW) input - GPD48
- Removable aluminized steel flame spreaders (2)
- "Snap" throttle thermostat for quick recovery (650°F/ 345°C maximum temperature)
- 100% automatic pilot safety shut-off valve
- Stainless steel front and sides
- Open door lies flush to hearth for easy loading and unloading.
- Easy-access door to burner compartment and gas control valve
- 48" (1219mm) x 36" (914mm) and 60" (1524mm) x 36" (914mm) hearth models to match production needs
- 8" (203mm) high oven cavity

- Heat damper system provides top to bottom heat adjustment within cooking chamber
- "Cool Touch" door handle for safe, comfortable operation.
- Canopy Flue Diverter
- 3/4" NPT manifold connection - right rear and side connection
- Double deck models available (suffix -2)
- One year limited parts and labor warranty

Optional Features:

- Direct flue diverter replaces canopy diverter and allows oven to be connected to an approved 6" (152mm) flue pipe and vented to exterior of building.
- 10-gauge, stainless steel legs (specify single or double deck)
- Stainless steel top

Specifications:

Garland Pyro Deck Gas Pizza/Baking Oven, Model GPD48 with 96,000BTU, (28.1kW), or GPD60 with 122,000BTU, (35.7kW), input per hour, per deck to Pyrorock oven hearth. Full-width oven door, flush to hearth for easy loading/unloading. "Cool Touch" door handle for safe, comfortable operation. Heat damper system to regulate top to bottom heat. Easy access doors to burner and gas valve. Stainless steel front and sides, aluminized top, black powder coat epoxy legs. UL, CUL Classified and NSF listed.



Installation Notes:	
Non-Combustible & Combustible Wall Clearances	
Sides	Back
1" (25mm)	6" (152mm)
Entry Clearance:	
Crated	Uncrated
35" (889mm)	26" (660mm)
Manifold Operating Pressure:	
Natural	Propane
6" WC (15mbar)	10" WC (25mbar)
Please specify gas type when ordering	
NOTE: Data applies only to North America	

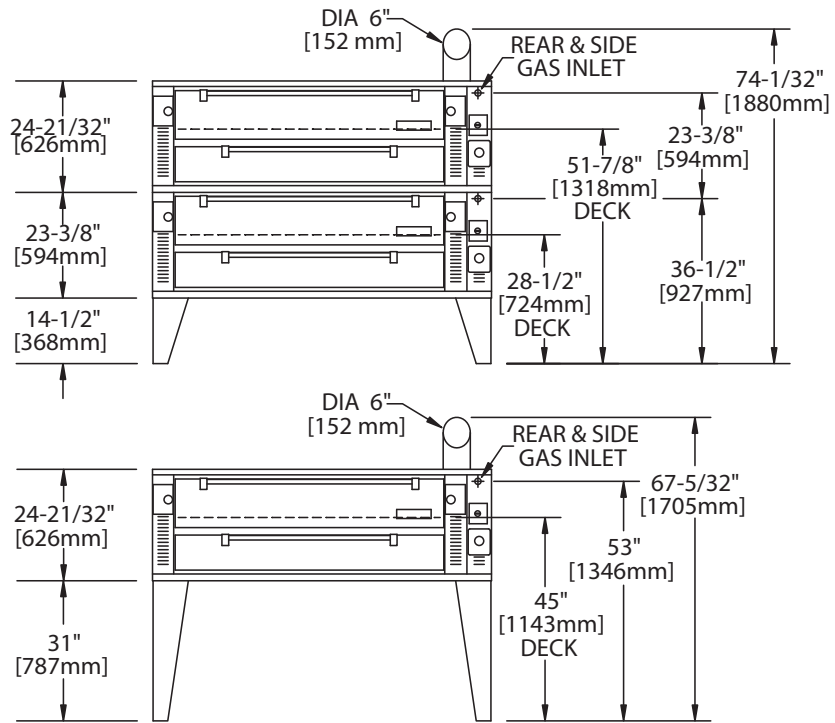

INPUT SPECIFICATIONS Natural Or Propane			
MODEL	BTU/HR	KW	GAS INLET
GPD48	96,00	28.1	3/4" N.P.T.
GPD60	122,000	35.7	3/4" N.P.T.
GPD48-2	192,000	56.2	1" N.P.T.
GPD60-2	244,000	71.4	1" N.P.T.

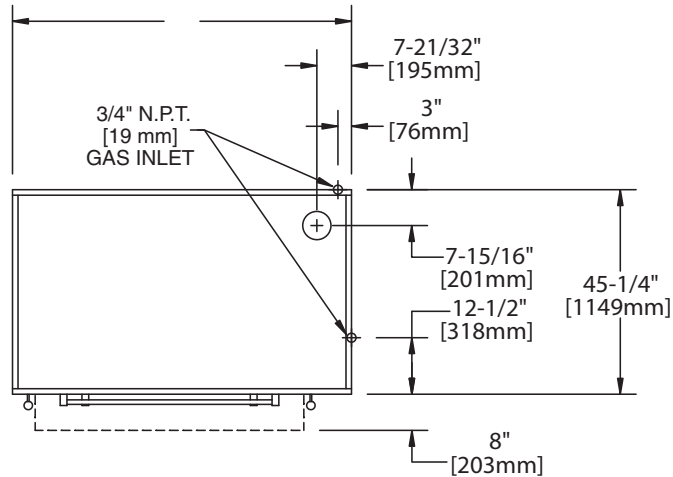

Gas Input ratings shown here are for installations up to 2,000-ft. (610m) above sea level. Specify altitudes over 2,000 ft.

MODEL NUMBER	Interior Dimensions: In (mm)			Exterior Dimensions In (mm)			Cu Ft.	Ship Wt. Lb/Kg
	W	H	D	W	H (w/NSF legs)	D		
GPD48	48 (1220)	8 (203)	36 (914)	63 (1600)	52-3/4 (1340)	45-1/4 (1149)	64	810/368
GPD60	60 (1524)	8 (203)	36 (914)	75 (1905)	52-3/4 (1340)	45-1/4 (1149)	82	1000/454
GPD48-2	48 (1220)	8 (203)	36 (914)	63 (1600)	62-1/2 (1588)	45-1/4 (1149)	128	1600/727
GPD60-2	60 (1524)	8 (203)	36 (914)	75 (1905)	62-1/2 (1588)	45-1/4 (1149)	164	1975/898