



*Model MCO -G-5-R*

### Specification:

Garland Master Half-Size gas convection oven. 60,000 BTU (17.6 kW) / cavity, 1/3HP fan motor with 2-speed fan control. Electronic spark ignition. Porcelain enameled oven interior with coved corners, 5 oven racks and 7-position rack guides, measures 14-1/4" (362mm) wide x 20" (508mm) high x 20-3/4" (527 mm) deep. Stainless steel front, top, and sides. RH or LH control (specify).

UL, CUL Classified and NSF Listed.



### Standard Features:

- Master 200 Solid State Digital control with 150°F (66°C) to 500°F (260°C) temperature range, and 60 minute electromechanical timer
- Electronic spark ignition, including automatic pilot system with 100% safety shut off
- 2-speed fan control w/1/3HP fan motor
- Total of 60,000 BTU (17.58 kW) loading per oven cavity
- Natural or propane gas
- Stainless steel front, sides, and top
- Single door w/double pane thermal window
- Control panel on RH side w/door hinged on LH side, "-L" models; control panel on LH side with door hinged on RH side, "-R" models
- 6" (152mm), adjustable stainless steel legs
- Porcelain enameled oven interior with coved corners
- 5 chrome plated oven racks on 7-position rack guides
- Double deck models available (change-5 to -25)
- One year limited parts & labor warranty (USA & Canada only)
- Five year limited door warranty, excluding window (USA & Canada only)

### Optional Features:

- Extra oven racks
- Swivel casters with front brakes, (not available for single-deck models)
- Stainless steel open stand: 28" (711mm) high with square tubular legs, bottom shelf, (optional casters add 4-1/2" / 114mm to height)
- Direct flue diverter collar, with 6" (152mm) oval connection
- Solid stainless steel door, (no additional charge)
- 3/4" gas flex hose and quick disconnect
- Deck fasteners, (flanged feet)

*NOTE: Ovens supplied with casters must be installed with an approved restraining device.*





Item #: \_\_\_\_\_  
 Models: MCO-G-5/25-L/R  
 Product Name: Master Half-Size Gas Convection Oven

MODEL NUMBER	NATURAL GAS	PROPANE	ELECTRICAL SUPPLY
		4.0" WC, (10 mbar)	10.0" WC, (24.9 mbar)
MCO-G-5L MCO-G-5R	60,000 BTU/hr (17.6 kW/hr) Orifice #37 DMS	60,000 BTU/hr (17.6 kW/hr) Orifice #51 DMS	Single Phase 60Hz, 6.0 Amps 6-ft. Line Cord Supplied
MCO-G-25L MCO-G-25R	120,000 BTU/hr (35.2 kW/hr) Orifice #37 DMS	120,000 BTU/hr (35.2 kW/hr) Orifice #51 DMS	Single Phase 60Hz / 6.0 Amps (2) 6-ft. Line Cords Supplied

INTERIOR DIMENSIONS, (PER DECK)				SHIP WT.
MODEL #	WIDTH	HEIGHT	DEPTH	lbs. / kg
MCO-G-5	14.25 (362mm)	20 (508mm)	20.75' (527mm)	340; 155
MCO-G-25	14.25 (362mm)	20 (508mm)	20.75' (527mm)	680; 310

Models shown are:  
 L, with controls on right side and the door hinged on left side;  
 R has controls on left side with door hinged on right side.

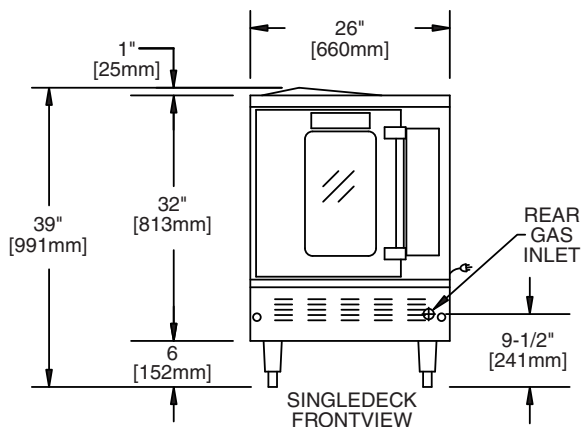
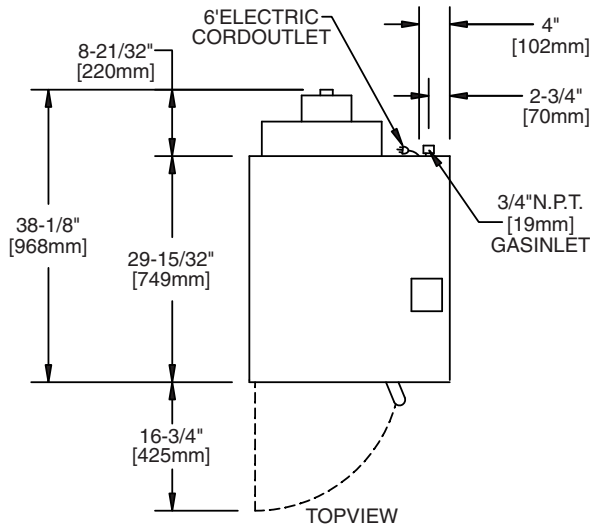

Gas Input Ratings shown here are for installations up to 2,000 ft. (610mm) above sea level. Specify altitudes over 2,000 ft.  
 Commercial cooking equipment requires an adequate ventilation system. For additional information, refer to the National Fire Protection Association's standard NFPA96, "Vapor Removal from Cooking Equipment." (NOTE: For North America only)  
 Please specify gas type when ordering.

