

Pressure Fryers

PFG-600 gas pressure fryer
PFG-600 with Computron 8000® control module

Pressure fryers use controlled low pressure for faster cooking at lower temperatures. This method seals in the food's moisture and natural juices while sealing out excess shortening for healthier, better-tasting, hot fresh food.

Description

Henny Penny pressure fryers represent one of the most profitable, efficient and space-saving methods of high-volume cooking.

- The PFG-600 cooks up to 12.5 lbs. (5.6 kg) of food per load from five square feet of floor space.
- Choose Computron 8000® control option for programmable operation.
- Built-in filtration system extends shortening life at optimal levels.



Optional Computron 8000® control

- Large 16-character digital display with multiple language settings.
- Automatic or manual idle, melt cycles.
- 10 programmable cook cycles.
- Automatic load compensation.
- Programmable on/off pressure.
- Optional filter enforcement.
- Temperature display in °F or °C.
- Cook Cycle Usage Summary.
- Programmable user password.
- Daily statistics for past 7 days.

Main Features

- Standard electro-mechanical control with easy to use temperature and timer controls.
- Stainless steel rectangular fry pot promotes more even cooking.
- Built-in filtration system.
- Cast aluminum alloy lid.
- Heavy duty lid hinge, spring and front lid latch.
- Color keyed locking spindle engages pressure seal.
- Patented design keeps lid locked until pressure drops to 1 psi.
- Automatic pressure release valve.
- Baffled exhaust stack.
- Channel underneath lid directs condensation away from hot shortening when lid is raised.
- Raised edge on frier top catches spills.
- Cook cycle completion signal.



Accessories shipped with unit:

- (1) Set of cleaning brushes
 - (5) PHT filter envelopes
 - (1) Tube of molycote lube
- Installation, operating and service manual

Options available separately:

- Heavy duty casters (2 locking)
- Filter pan dolly
- Rinse hose attachment
- Open basket and handle
- 4-tier stainless steel basket and handle
- Non-woven carbon filter envelopes

Henny Penny Corporation
P.O. Box 60

PFG-600 Specifications

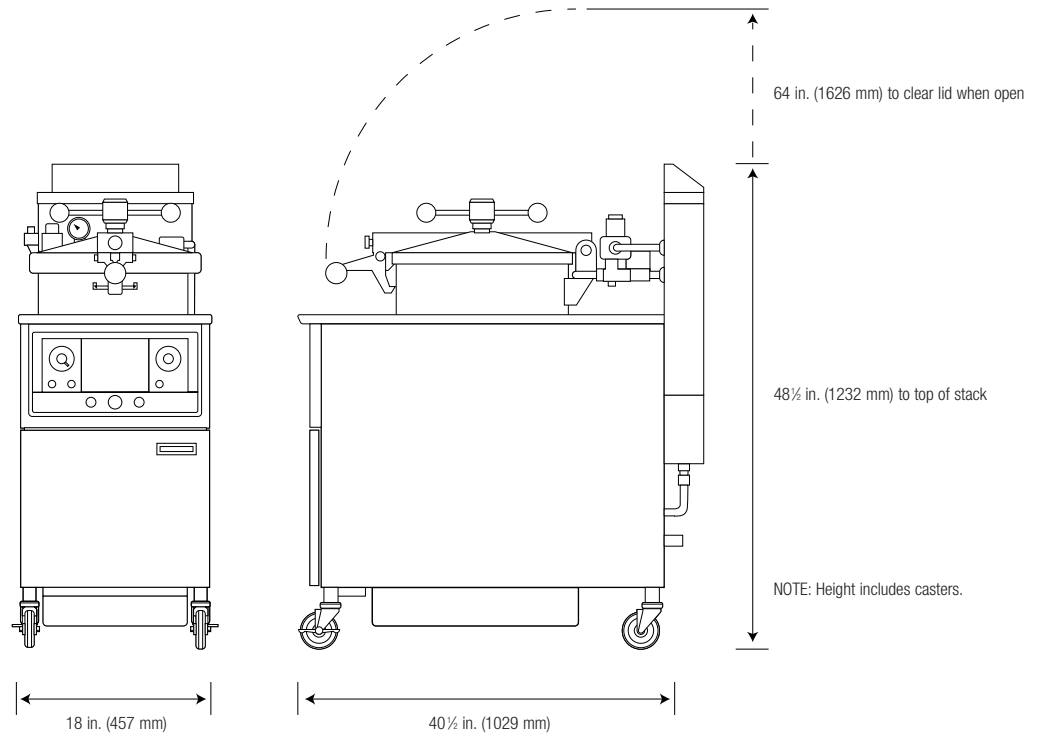

Dimensions

Clearances

Sides and back: 6 in. (152 mm)

Floor Space

5 sq. ft. (.46 m²)

Capacity

Product
Shortening

12.5 lbs. (5.7 kg)
43 lbs. (19.5 kg)

Heating Format

Natural or propane gas.
(1) burner
(1) 1/2 in. connection
80,000 BTU/hr (23.4 kw)

Pressure

Operating pressure: 12 psi. Safety valve setting: 14.5 psi.

Shipping Weight

325 lbs. (147 kg)

Listings

CSA, UL Sanitation, CE

Electrical

Voltage	Phase	Cycle/Hz	KW	Amps
120	1	50 or 60	1.15	9.6
220-240	1	50 or 60	1.15	5.2-4.8
230	1	50 or 60	1.15	5.0
All international voltages available.				
Optional power cord and plug can be supplied for 1 phase 120 v units, only.				
Plug type: 2-pole, 3-wire, NEMA 5-15P				

Specifications subject to change without notice

Order from:

