



# AJ-44T Vision Series



## Standard Features

- 204 racks per hour hi-temp sanitizing rinse.
- 0.70 gallons per rack hi-temp sanitizing rinse.
- Incoming water pressure regulator
- Standard 25" clearance allows owner operators the ability to wash large utensils, trays, and bun pans.
- Totally electro-mechanical; no solid state controls utilized.
- Fully automatic including auto-fill.
- Completely self-draining stainless steel wash pump.
- Exclusive "Energy Guard" controls system operates wash and rinse sections only when a rack is being washed or rinsed.
- A long 18" wash section as well as 18" separation between wash and rinse produces superior results.
- Convenient, externally operated lever drain.
- Stainless steel frame, legs, adjustable bullet feet, and front appearance panel are all standard.
- Standard 8" vent cowls/splash shields on both wash and rinse ends of the machine.
- Heavy gauge construction for extra ruggedness and durability.

## Power/Connections

| Approximate Total Load | AMPS |
|------------------------|------|
| 208V / 60HZ / 3PH      | 56.7 |
| 208V / 60HZ / 1PH      | 96.8 |
| 230V / 60HZ / 3PH      | 48.1 |
| 230V / 60HZ / 1PH      | 82.0 |
| 460V / 60HZ / 3PH      | 24.1 |

### Booster Heater Options

| External 40°F Min. Rise | KW | AMPS |
|-------------------------|----|------|
| 208V / 60HZ / 3PH       | 15 | 41.6 |
| 230V / 60HZ / 3PH       | 15 | 37.7 |
| 460V / 60HZ / 3PH       | 15 | 18.8 |

| External 70°F Min. Rise | KW | AMPS |
|-------------------------|----|------|
| 208V / 60HZ / 3 PH      | 27 | 75.0 |
| 230V / 60HZ / 3PH       | 27 | 67.8 |
| 460V / 60HZ / 3PH       | 27 | 33.9 |

### Venting Requirements (CFM)

|            |     |
|------------|-----|
| Input end  | 200 |
| Output end | 400 |
| Total CFM  | 600 |

### Water Requirements

|                                         |       |
|-----------------------------------------|-------|
| Incoming Water Temperature (°F)         | 180   |
| With 15 KW booster heater option (°F)   | 140   |
| With 27 KW booster heater option (°F)   | 110   |
| Gallons per hour:                       |       |
| Hi-temp sanitization                    | 144   |
| Gallons per rack:                       |       |
| Hi-temp sanitization                    | 0.70  |
| Wash Tank Capacity (Gallons)            | 22.5  |
| Incoming Waterline Size (IPS) (Minimum) | 1/2   |
| Flow Pressure (PSI)                     | 15-25 |
| Flow Rate Minimum (GPM)                 |       |
| Hi-temp sanitization                    | 2.4   |
| Drainline Size IPS (Minimum) (Inches)   | 1 1/2 |

## Performance/Capacities

### Operating Capacity

|                      |      |
|----------------------|------|
| Racks per hour       |      |
| Hi-temp Sanitization | 204  |
| Dishes per hour      |      |
| Hi-temp Sanitization | 5100 |
| Glasses per hour     |      |
| Hi-temp Sanitization | 5100 |

### Operating Temperatures

|                        |     |
|------------------------|-----|
| Wash Tank-°F (Minimum) |     |
| Hi-temp Sanitization   | 160 |
| Rinse-°F (Minimum)     |     |
| Hi-temp Sanitization   | 180 |

### Dimensions (Inches)

|                                 |     |
|---------------------------------|-----|
| Length between dishtables       | 44  |
| Machine width                   | 25  |
| Wall Clearance (Minimum)        | 4.5 |
| Cavity/dish clearance (Maximum) | 25  |

### Shipping Information

|                     |     |
|---------------------|-----|
| Weight (Lbs)        | 641 |
| Dimensions (Inches) |     |
| Length              | 76  |
| Depth               | 40  |
| Height              | 78  |
| Volume (Cubic feet) | 138 |

### Steam Coil Tank Heat

|                                |       |
|--------------------------------|-------|
| Steam Connection IPS (Inches)  | 3/4   |
| Steam Flow Pressure (PSIG)     | 10-20 |
| Consumption @ 15 PSIG (Lbs/hr) | 60    |

|                              |     |
|------------------------------|-----|
| Wash Pump Motor HP           | 2   |
| Wash Pump Capacity (GPM)     | 270 |
| Wash Tank KW                 | 18  |
| Conveyor Motor Horsepower    | 1/4 |
| Conveyor Speed (Feet/minute) |     |
| Hi-temp Sanitization         | 5.7 |

## Specifications

**NOTE:** The AJ-44T series conveyor dishmachines are NSF International Inc. (NSF) Certified & Underwriters Laboratories Inc. (UL) Listed. They also meet the requirements of A.S.S.E. Standard No. 1004.

**PERFORMANCE:** Fully automatic, single tank, rack conveyor dishwasher designed to wash, rinse, and sanitize tableware and utensils commonly associated with the preparation and consumption of food items in a commercial foodservice operation. Sanitization is accomplished through hi-temp sanitization utilizing 180-195°F fresh water rinse. The unit conveys standard 20" x 20" dishracks through a recirculating detergent laden wash section where 270 gallons per minute (GPM) of 160°F wash water is pumped over the dishrack to remove the food soil. The rack is then conveyor driven into a final rinse section where a fresh water final rinse spray system removes residual detergent and sanitizes. For hi-temp sanitizing, the unit must be installed to a potable water line capable of supplying 144 gallons per hour between 180-195°F at 20 PSI flow pressure for maximum hourly rack capacity of 204 racks per hour.

**CAUTION:** Use of sodium hypochlorite (chlorine) may have an adverse effect on materials including, but not limited to, silver and silver plate, pewter, and aluminum.

**CONSTRUCTION:** All stainless steel components are 304 series stainless steel. No 400 series stainless steel and/or plastics are utilized. Frame is constructed of 2" diameter stainless steel tubing formed and completely saddle welded for superior strength. The wash tank, and rinse chamber are formed and heliarc welded 16 gauge #2B finish. Hood is 16 gauge #3 finish. Stainless steel feet are adjustable  $\pm 1/2"$ .

**WASH PUMP:** Internal wash pump located inside the wash tub is totally stainless steel as is the impeller. The wash pump itself is totally integral with the motor. Wash water is recirculated from the wash tank through the manifolds and wash arm system at the rate of 270 GPM.

**WASH PUMP MOTOR:** A 2 HP totally enclosed, fan cooled type motor drives the wash pump and arms. Single-phase motors are capacitor start, induction run with internal thermal overload protection. Three-phase motors are induction run with external overload protection. Motor shaft is supported by permanently lubricated grease packed ball bearings.

**CONVEYOR SYSTEM:** Racks are conveyed through the machine by a center-mounted, heavy-duty stainless steel pawl bar with stainless steel cast, counter-weighted, wide surface pawls. The pawl bar is designed

to not interfere with spray patterns in the wash, and rinse section. The pawl bar is driven by a 1/4 HP motor and worm drive gear reduction unit. The conveyor motor itself is totally enclosed, non-ventilated. Single-phase motors are capacitor start, induction run with internal thermal overload protection. Three-phase motors are induction run with external overload protection. Pawl bar conveyor drive unit is mounted on the left hand side of the machine and is enclosed with a removable stainless steel cover. Maximum conveyor speed is 5.7 feet per minute.

**CHAMBER:** The chamber has a standard clearance of 25" which is the highest clearance in the industry—even higher than competitive higher hood options. This adds to the versatility of the machine since you can easily accommodate larger utensils such as sheet pans and 60 quart mixing bowls.

**CONTROLS:** Controls are located in a stainless steel control box mounted on top of the machine for ease of access and increased reliability. Power "ON/OFF" switch is the only manual switch required. "Energy Guard" fully automates the machine and utilizes switching logic to operate wash and rinse sections only when a rack is being washed or rinsed as well as turning the conveyor off when a rack exits the machine and there are no other racks in the machine. Regardless of machine voltage, all control circuitry will be operated from a 110 volt control circuit transformer. The unit is completely wired with 105°C, 600V thermoplastic insulated wire and routed through UL approved conduit. The control circuit itself is protected by a manual reset 1 AMP overload protector located on the front of the control box.

**FILL:** Initial fill of wash tank is automatic when machine is initially energized. The wash tank fill line needs to be hooked up to a 180°F minimum potable water line which normally would be supplied by an external booster heater or our optional Hatco booster heater packages. Fill is controlled by a standard solenoid valve and vacuum breaker assembly. The incoming water solenoid is activated by a stainless steel float system located in the wash tank for required maintenance of the wash tank water level.

**RECIRCULATING WASH:** The wash tank itself has a 22.5 gallon capacity and maintains that level with a skimming type overflow. Washing action is accomplished by recirculating detergent laden water in the wash tank through upper and lower wash arms. Make-up water comes from the final rinse section and is controlled at approximately 2 GPM. The arms themselves are extended and create a longer wash section than competitive models. Wash performance commences 5" into the

machine unlike other 44" single tank conveyors. Wash section is automatically activated by racks as they pass through. Wash arms, upper and lower, contain 43 separate stripping nozzles for superior performance. Both wash arms are easily removable and along with removable wash arm end caps, are easily cleanable without the use of tools. Large stainless steel strainer pans, as well as a pump intake strainer for secondary protection are readily accessible and removable for cleaning purposes. Knockouts and connections are provided to allow easy installation of detergent concentration sensor and dispenser tubing by others.

**FINAL RINSE:** Fresh pressurized rinse water enters the machine through a standard "Y" strainer, solenoid valve, and approved vacuum breaker assembly and is plumbed to upper and lower final rinse arms located at the output end of the machine. Single rows of fan jet nozzles are located on both rinse arms. Connection points are provided for both rinse agent injection and sodium hypochlorite (low-temp chemical sanitizing machines only) into the final rinse line by others. Total final rinse flow rate is 2.4 GPM.

**DRAIN, OVERFLOW, AND MAKE-UP:** The machine is designed to maintain appropriate wash tank water levels at all times even at low pressures. The overflow system is designed to automatically skim the surface of the wash tank. Make-up water from the final rinse system not only replenishes the wash water but also helps maintain appropriate water levels as well as appropriate wash tank temperatures. A large lever located on the front panel of the machine operates a drain valve and drains the machine completely.

**PRESSURE REDUCING VALVE:** Factory installed on incoming water line to control water pressure.

## Additional Standard Equipment:

---

- Vent cowls/splash shields with 4" x 16" openings covered with removable plates for connection to exhaust ducts when required.
- Flexible strip curtains provided at the ends of the vent cowls as well as at the ends of the machine and separating the prewash, wash, power rinse, and final rinse sections.
- Extra large inspection doors located on front of machine for easy access and cleanability.
- Safety door switches shut down machine should any door be opened during operation.
- Stainless steel front appearance panel.
- Positive low level water protection for wash and power rinse tank heat.
- Sealed dial type thermometers for the prewash, wash, power rinse and final rinse temperatures.

## Optional Mandatory Specifications:

---

### WASH TANK HEATING EQUIPMENT (Choose One):

**ELECTRIC:** Low watt density 18 KW tubular heating elements mounted inside the wash tank and easily removable from the outside. The heaters are protected by a stainless steel float system as well as high limit overload protection. Water temperature in the tanks is controlled and maintained by fast reacting thermostats which control the heating elements.

**STEAM:** Stainless steel coils are utilized rather than injectors so that contaminated steam being injected into the wash water is not an issue. Stainless steel tubular steam coils are mounted inside the wash and power rinse tanks below the optimum water level. The coils are protected by a stainless steel float system. An external steam "Y" strainer and high temperature steam solenoid regulates the flow of steam through the coils. Temperature in the tanks is controlled and maintained by fast reacting thermostats which control the operation of the steam solenoids. A float and thermostatic steam trap is provided and removes steam condensate from the steam coils which can either be plumbed to a drain or pumped back to the boiler if a condensate return system is available. Steam coils require a minimum of 10 PSIG flowing steam supply and a maximum of 20 PSIG. Install with a steam pressure regulator (by others) if steam supply exceeds 20 PSIG.

## Optional Features and Accessories:

---

**EXTERNAL 40°F ELECTRIC BOOSTER HEATER:** External Hatco booster heater boosts incoming 140°F water to a minimum of 180°F for hi-temp sanitizing rinse. Custom features include castone-lined tank, low water cutoff, pressure relief valve, as well as a pressure reducing valve. Unit is located next to the output end of the machine, completely preplumbed. Power to the booster heater requires a separate electrical connection. Unless specified otherwise, electrical characteristics of the booster heater will be the same as that of the dishwasher. The booster heater is approximately 15 KW and is available in 208/240/480 voltages/3 phase only.

**EXTERNAL 70°F RISE BOOSTER HEATER:** External 27 KW Hatco booster heater capable of boosting incoming 110°F water a minimum of 70 degrees to a minimum of 180°F for hi-temp sanitizing rinse. Unit is located next to the output end of the machine and comes completely preplumbed. Power to the booster heater requires a separate electrical connection. Unless specified otherwise, electrical characteristics of the booster heater will be the same as that of the dishwasher. The booster heater is available in 208/240/480 voltages/3 phase only.

**STEAM BOOSTER HEATER:** Sized to be connected to a standard 140°F incoming water supply in order to insure 180-195°F hi-temp sanitizing final rinse requirements. Unit comes complete with steam "Y" strainer and high temperature steam solenoid as well as a steam pressure relief valve. Water temperature is controlled and maintained by a fast reacting thermostat which controls the operation of the steam solenoid. A float and thermostatic steam trap is provided and removes steam condensate from the coil which can either be plumbed to a drain or pumped back to a boiler if a condensate return system is available. Must be installed with a steam pressure regulator (by others) if steam supply exceeds 20 PSIG.

**TABLE LIMIT SWITCH:** Factory wired to machine and mounted to the backsplash of the table in the field. Prevents damage to conveyor drive system, racks, and dishes due to racks backing up on the output end of the machine. Highly recommended for clean dishtables less than 10 feet in length.

**VENT COWL COLLARS:** Factory installed 4" x 16" x 7" high collars located on the vent cowls to allow easy connection to an external exhaust system including a standard "pant-leg" type exhaust duct. Includes adjustable and lockable damper flap for fine tuning exhaust system to remove appropriate CFM requirements.

**50 CYCLE (HERTZ) ELECTRICAL CHARACTERISTICS:** Units are available in 50 HZ in the following voltages: 208V/1 or 3PH, 230V/1 or 3PH, 380V/3PH, and 460V/3PH. Units operating at 50 HZ are not submitted for UL Listing.

**SIDELOADER:** Factory installed option on input end of conveyor machine. This feature allows the machine to be installed close to a corner and maximize dishroom space. The sideloader option is available in both the hooded and unhooded versions. See separate spec sheets for details.

**EXHAUST VENT FAN CONTROL:** Automatically turns exhaust vent fan on when rack enters the machine. Delay timer also turns off the exhaust vent fan 5-10 seconds after rack exits machine when no other racks are being conveyed through the machine.

**FLANGED FEET:** Available for installations where permanent mounting to the floor is required. Fully adjustable for required height.

**WATER HAMMER ARRESTOR:** Installed inside the supply line.

# AJ-44T Vision Series

# Conveyors

## Specifications

Note: Check and/or copy all that apply.

**AJ-44T Series Rack Conveyor Dishwasher – Item No.** \_\_\_\_\_

Shall be a Jackson AJ-44T Series, single tank rack conveyor dishwasher. Sanitization shall be accomplished by using:

\_\_\_\_\_ Hi-temp (180°F minimum) sanitizing rinse

Electrical characteristics shall be:

\_\_\_\_\_ 208V/60HZ/3PH

\_\_\_\_\_ 208V/50HZ/3PH

\_\_\_\_\_ 208V/60HZ/1PH

\_\_\_\_\_ 208V/50HZ/1PH

\_\_\_\_\_ 230V/60HZ/3PH

\_\_\_\_\_ 230V/50HZ/3PH

\_\_\_\_\_ 230V/60HZ/1PH

\_\_\_\_\_ 230V/50HZ/1PH

\_\_\_\_\_ 460V/60HZ/3PH

Wash tank heating shall be a minimum of 160°F for hi-temp applications and accomplished by:

\_\_\_\_\_ 18 KW electric heating elements thermostatically controlled.

\_\_\_\_\_ Stainless steel steam coils thermostatically controlled.

Direction of rack flow shall be (when standing in front of machine):

\_\_\_\_\_ Right-to-Left

\_\_\_\_\_ Left-to-Right

## Unit shall have the following features:

- 204 racks per hour utilizing 0.70 gallons of water per rack for hi-temp sanitizing rinse.
- Incoming water pressure regulator.
- Minimum 25" clearance throughout machine.
- Exclusive "Energy Guard" controls system energizes prewash, wash, recirculating rinse, and final rinse sections only when a rack is in place.
- Completely electro-mechanical; no solid-state controls.
- Fully automatic operation including auto-fill.
- Stainless steel wash pump and impeller and completely self-draining.
- Wash section must be a minimum of 18" in length as well as 18" separation between recirculating wash and final rinse.
- Convenient, externally operated lever drain.
- Vent cowls/splash shields with extra curtains on both wash and rinse ends of the machine.
- Stainless steel frame, legs, adjustable bullet feet, and front appearance panel.
- All 304 series stainless steel construction; no. 400 series stainless steel and no plastics utilized.

## Unit shall have the following features as optional extras:

\_\_\_\_\_ External Hatco 15 KW booster heater for a minimum 40°F rise and available in the following voltages:

\_\_\_\_\_ 208V/50 or 60HZ/3PH

\_\_\_\_\_ 240V/50 or 60HZ/3PH

\_\_\_\_\_ 480V/50 or 60HZ/3PH

\_\_\_\_\_ External Hatco 27 KW booster heater for a minimum 70°F rise and available in the following voltages:

\_\_\_\_\_ 208V/50 or 60HZ/3PH

\_\_\_\_\_ 240V/50 or 60HZ/3PH

\_\_\_\_\_ 480V/50 or 60HZ/3PH

\_\_\_\_\_ Steam booster heater.

\_\_\_\_\_ Table limit switch completely prewired and extending from the output end of the machine, 9'0" long.

\_\_\_\_\_ Table limit switch completely prewired and extending from the output end of the machine, 12'0" long.

\_\_\_\_\_ Table limit switch completely prewired and extending from the output end of the machine, 15'0" long.

\_\_\_\_\_ Installed 4" x 16" x 7" high vent cowl collars for easy connection to an external exhaust system and including adjustable and lockable damper flaps.

\_\_\_\_\_ output end only \_\_\_\_\_ input end only

\_\_\_\_\_ both ends

\_\_\_\_\_ Pressure reducing valve factory installed on machine.

\_\_\_\_\_ Incoming water hammer arrestor installed.

\_\_\_\_\_ Sideloader installed on input end of machine.

\_\_\_\_\_ unhooded sideloader \_\_\_\_\_ hooded sideloader

\_\_\_\_\_ Exhaust fan control controls external exhaust fan power and duration time.

\_\_\_\_\_ Flanged feet for permanent in-place mounting to the floor.



# AJ-44T

## Left to Right or Right to Left Operation Shown

### Legend to Drawing

- A**– Machine water inlet 1/2" I.P.S., 180°F Hi-temp, 69 5/8" above finished floor
- B**– Electrical connection - See table for amperage requirements (On back)
- C**– Drain connection-1 1/2" I.P.S.
- D**– Vent collar 4"w. x 16" lg x 7" high - **Optional**
- E**– Vent collar standard
- \*F**– Incoming low pressure steam connection, 3/4" FPT (gate valve supplied)- **Optional**
- \*G**– Condensate return connection, 3/4" FPT (return to boiler feeder or open drain)
- \*Steam tank heat option only.
- Note:** All vertical dimensions are +/- 1/2" from floor due to adjustable bullet feet.
- Note:** Utility connections are identical regardless of direction of flow.

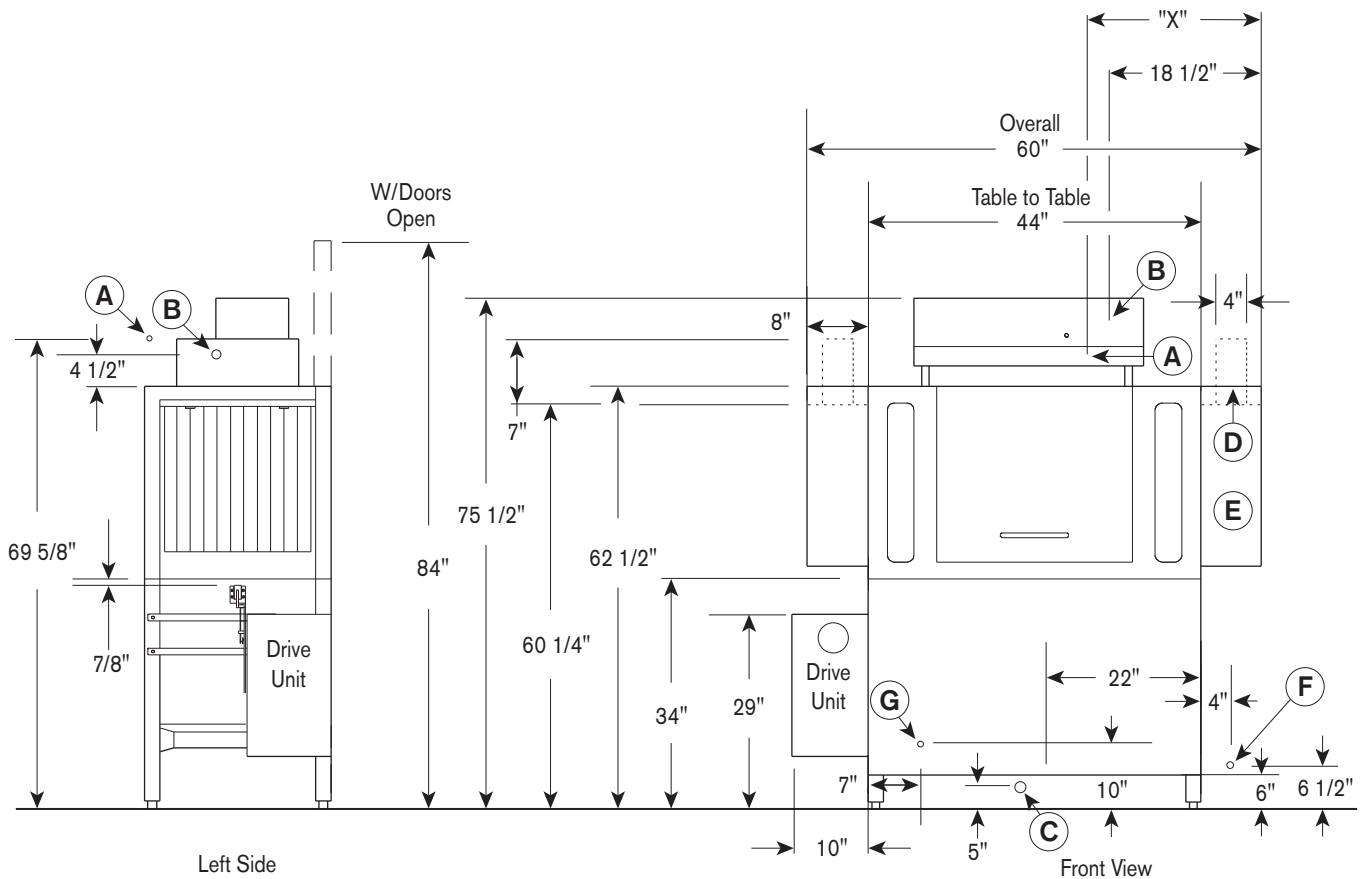
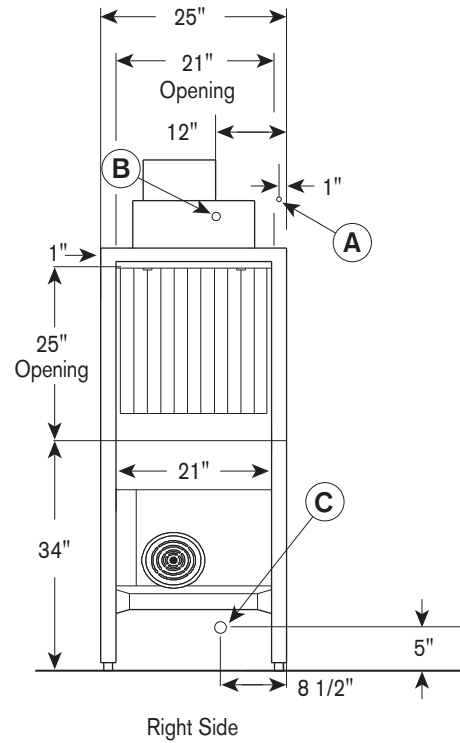

### Approximate Total Load Amps

| AJ-44 Series<br>Electrical Data | Electric Tank Heat<br>Models:<br>AJ44TE |      | Steam Tank Heat<br>Models:<br>AJ44TS |      | Optional 15 KW<br>Electric<br>Booster Heater |
|---------------------------------|-----------------------------------------|------|--------------------------------------|------|----------------------------------------------|
|                                 | 1-PH                                    | 3-PH | 1-PH                                 | 3-PH |                                              |
| 208 Volts 60 Cycles             | 96.8                                    | 56.7 | 10.3                                 | 6.7  | *3-PH Only<br>**41.6                         |
| 230 Volts 60 Cycles             | 82.0                                    | 48.1 | 10.3                                 | 6.7  | 37.7                                         |
| 460 Volts 60 Cycles             | N/A                                     | 24.1 | N/A                                  | 3.4  | 18.8                                         |

### Recommended Table Fabrication

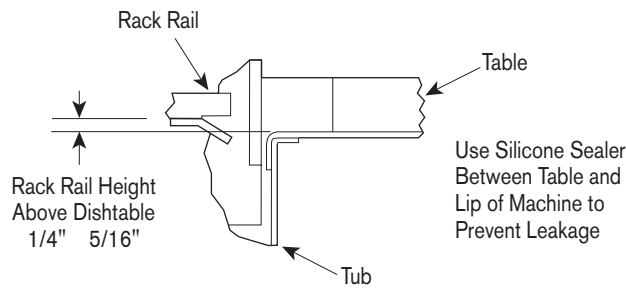

Note: Tub Will Accept a Table Flange Up to 24 7/8"

