



FL-10



Standard Features

- Water usage – 6.5 gallons per cycle
- 12 cycles per hour
- Fully automatic cycle - 260 seconds
- Incoming water pressure regulator
- Internally mounted electric booster heater
 - Capable of minimum 60°F temperature rise for required 180°F minimum sanitizing rinse temperature
- One (1) 9 KW Heating Element in a 9 1/2 gallon rinse tank
- Two (2) Rotating Wash Arms - 1 upper & 1 lower
- Stationary Rinse Nozzles - Top & Bottom
- 30 Gallon Wash Tank
- Electromechanical controls
 - Safety door switch
 - Temperature control thermostat and low water protection
- Construction - 12 & 14 gauge stainless steel
- Operational and cleanability features
 - High pressure, all stainless steel wash arms
 - 28 3/4" wide x 30 1/2" high door opening
 - Double filtration system
 - Externally mounted spray down hose with spray gun nozzle
 - Waterproof LED digital gauges
 - Three wash cycles
- Installation features
 - Stainless steel control panel - easily accessible
 - Adjustable bullet feet
 - Detergent/rinse additive signal connection fuse box

Power/Connections

Electrical Rating

Wash Pump Motor Horsepower			7.5
Full Load Amps	208V	230V	460V
Electric	71.0	65.2	33.6
Steam Injectors	46.0	42.6	22.3
Steam Coils	22.0	20.0	11.0
Gas	46.0	42.6	22.3

Gas Requirements

Gas Connection (NPT)		1/2
Natural Gas (Inches-water column)		
Minimum inlet		6.0
Main Manifold		3 1/2
BTU		36,000
Propane (Inches-water column)		
Minimum inlet		11.0
Main Manifold		6.0
BTU		36,000

3" Stainless steel chimney on back of machine

Steam Requirements

Steam connection (NPT)		3/4
Injectors (Lbs per hour)		15
Coils (Lbs per hour)		33

Water Requirements

Inlet Temperature (Minimum)		140°F
Gallons per Hour		78
Gallons per Rack		6.5
Waterline Size IPS (Minimum) (Inches)		1/2
Drainline Size IPS (Minimum) (Inches)		1 1/2
Flow Pressure (PSI)		15-25

Performance/Capacities

Operating Capacity

Racks per Hour	12
----------------	----

Operating Cycle (Seconds)

Light		Depth	44 (46 gas)
Wash Time	180	Height	84 1/2
Dwell Time	20	Height (door open)	
Rinse Time	60	Electric	103 1/2
Total Cycle	260	Gas	106

Medium

Wash Time	300	Wall Clearance (Minimum)	16
Dwell Time	20	Wall Clearance (Control Panel Side)	36 Wall
Rinse Time	60	Clearance (Back)	12
Total Cycle	380		

Heavy

Wash Time	420	Shipping Weight (Lbs.)	950
Dwell Time	20	Shipping Size (Inches)	
Rinse Time	60	Width	42
Total Cycle	500	Depth	60
		Height	90

Operating Temperatures

Wash – °F (Minimum)	150
Rinse – °F (Minimum)	180

Short Form Specifications

Item No. _____

Unit shall be LVO/Jackson* FL-10 Front Load door style hot water sanitizing pot & pan washer. Electrical characteristics to be ___ volts / 60 cycles / ___ phase operation with a 260 second automatic cycle using 78 gallons of 180° F. final rinse water per hour. Stainless steel construction to include hood, frame, wash tank, and adjustable feet. A 7.5 HP motor mounted to a pump with a impeller shall be mounted to the machine frame. As standard the unit shall include:

- Single point connections for all utilities
- Three Wash times cycle switch
- Side mounted control box with electro-mechanical
- Built-in water pressure regulator components.

Unit shall be NSF Certified and UL Listed.

*Units shall be manufactured by LVO Manufacturing Inc.

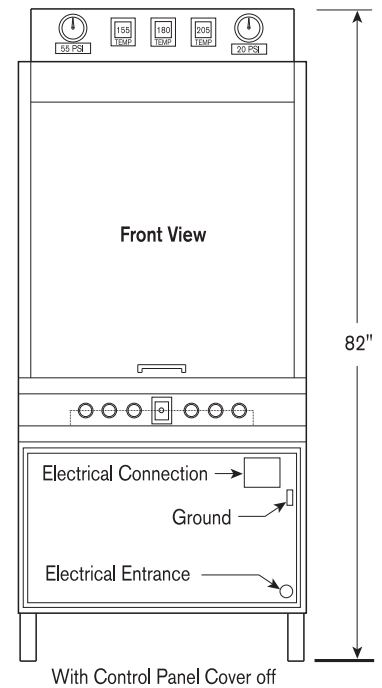
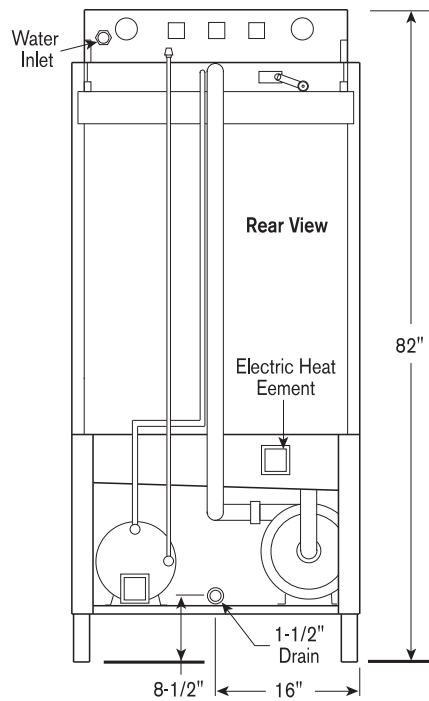
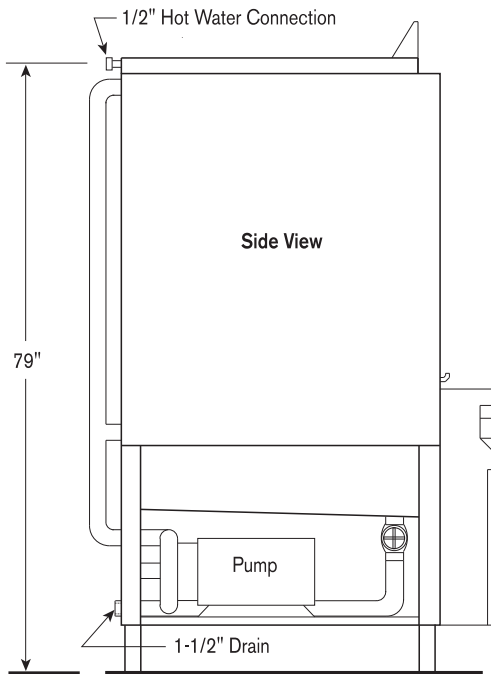
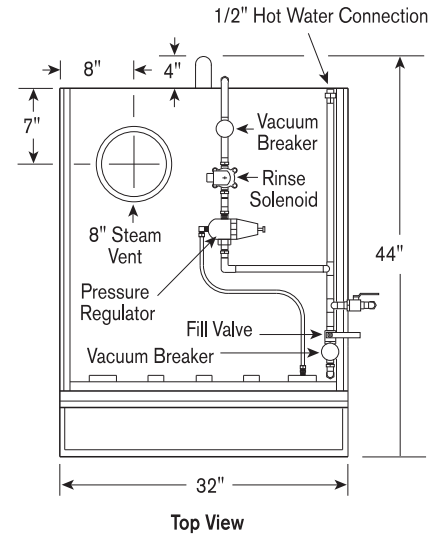

Note:
 Height with door open – 103-1/2"
 Door open width – 28-3/4"
 Height – 30"

