



# AJ-90 Vision Series



## Power/Connections

Approximate Total Load	AMPS
208V / 60HZ / 3PH	67.9
208V / 60HZ / 1PH	114.8
230V / 60HZ / 3PH	62.6
230V / 60HZ / 1PH	105.8
460V / 60HZ / 3PH	31.3

### Booster Heater Options

External 40°F Min. Rise	KW	AMPS
208V / 60HZ / 3PH	36	100.0
230V / 60HZ / 3PH	36	90.5
460V / 60HZ / 3PH	36	45.2

External 70°F Min. Rise	KW	AMPS
208V / 60HZ / 3PH	54	150.0
230V / 60HZ / 3PH	54	135.7
460V / 60HZ / 3PH	54	67.8

### Venting Requirements (CFM)

Input end	200
Output end	400
Total CFM	600

### Water Requirements

Incoming Prewash Tank Temperature (°F)	140
Incoming Wash Tank Temperature (°F)	180
With 36 KW booster heater option (°F)	140
With 45 KW booster heater option (°F)	110
Gallons per hour	279
Gallons per rack	1.03
Prewash Tank Capacity (Gallons)	16.0
Wash Tank Capacity (Gallons)	20.4
Incoming Waterline Size (IPS) (Minimum)	
Prewash Tank Fill	3/4
Wash Tank Fill/Rinse	3/4
Optimum Flow Pressure (PSI)	15-25
Flow Rate Minimum (GPM)	4.7
Drainline Size IPS (Minimum) (Inches)	1 1/2

## Standard Features

- 270 racks per hour hi-temp sanitizing rinse.
- 1.03 gallons per rack hi-temp sanitizing rinse.
- Incoming water pressure regulator
- Recirculating prewash feature virtually eliminates manual prerinsing and saves on labor.
- Exclusive Adjust-A-Peak feature (patented) allows the owner operator to manually adjust the speed of the conveyor system from 135 racks per hour all the way to maximum capacity of 270 racks per hour.
- Standard 25" clearance allows owner operators the ability to wash large utensils, trays, and bun pans.
- Prewash section has three upper arms and two lower arms.
- Totally electro-mechanical; no solid state controls utilized.
- Fully automatic including auto-fill.
- Prewash auto fill requires 110-140°F separate connection and does not fill through the booster heater.
- Self-draining stainless steel pumps and impellers.
- Exclusive "Energy Guard" controls system operates wash and rinse sections only when a rack is being washed or rinsed.
- A long 23" wash section as well as 23" separation between wash and rinse produces superior results.
- Convenient, externally operated lever drains.
- Deep well scrap basket conveniently located on front of machine facilitates removal of heavy food soil.
- Stainless steel frame, legs, adjustable bullet feet, and front appearance panel are all standard.
- Standard 8" vent cowls/splash shields on both wash and rinse ends of the machine.
- Heavy gauge construction for extra ruggedness and durability.

## Performance/Capacities

Operating Capacity		Operating Temperatures	
Racks per hour (NSF Rated)	270	Prewash Tank-°F	110-140
Dishes per hour	6750	Wash Tank-°F (Minimum)	160
Glasses per hour	6750	Rinse-°F (Minimum)	180
Steam Coil Tank Heat		Dimensions (Inches)	
Coil Size IPS (Inches)	3/4	Length between dishtables	90
Steam Flow Pressure (PSIG)	10-20	Machine width	25
Consumption @ 15 PSIG (Lbs/hr)	60	Wall Clearance (Minimum)	4.5
		Cavity/dish clearance (Maximum)	25
Shipping Information			
Prewash Pump Motor Horsepower	2	Weight (Lbs)	1054
Prewash Pump Capacity (GPM)	270	Dimensions (Inches)	
Wash Pump Motor HP	2	Length	120
Wash Pump Capacity (GPM)	270	Depth	40
Wash Tank KW	20	Height	78
Conveyor Motor Horsepower	1/4	Volume (Cubic feet)	217
Conveyor Speed (Feet/minute)	8.0		

## Specifications

**NOTE:** The AJ-90 series conveyor dishmachines are listed by the National Sanitation Foundation (NSF), Underwriters Laboratories Inc. (UL), and by the Canadian Standards Association (CSA). They also meet the requirements of A.S.S.E. Standard No. 1004.

**PERFORMANCE:** Fully automatic, single tank, rack conveyor dishwasher with a recirculating prewash designed to wash, rinse, and sanitize tableware and utensils commonly associated with the preparation and consumption of food items in a commercial foodservice operation. Sanitization is accomplished through hi-temp sanitization utilizing 180-195°F fresh water rinse. The unit conveys standard 20" x 20" dishracks through a recirculating prewash section where 120 gallons per minute (GPM) of 110-140°F water is pumped over the rack to mechanically prepare the tableware for washing. Next, the rack is conveyor driven into a detergent laden wash section where 270 (GPM) of 160°F (140°F in a low-temp chemical sanitizing machine) wash water is pumped over the dishrack to remove the food soil. Finally, the rack is conveyor driven into a final rinse section where a fresh water final rinse spray system removes residual detergent and sanitizes. For hi-temp sanitizing, the unit must be installed to a potable water line capable of supplying 279 gallons per hour between 180-195°F at 15-25 PSI flow pressure for maximum hourly rack capacity of 270 racks per hour.

**CONSTRUCTION:** All stainless steel components are 304 series stainless steel. No 400 series stainless steel and/or plastics are utilized. Frame is constructed of 2" diameter stainless steel tubing formed and completely saddle welded for superior strength. The prewash tank, wash tank, and rinse chamber are formed and heliarc welded 16 gauge #2B finish. Hood is 16 gauge #3 finish. Stainless steel feet are adjustable  $\pm 1/2$ ".

**PREWASH PUMP:** Internal prewash pump located inside the prewash tub is totally stainless steel as is the impeller. The prewash pump itself is totally integral with the motor. Prewash water is recirculated from the prewash tank through the manifolds and wash arm system at the rate of 120 GPM.

**WASH PUMP:** Internal wash pump located inside the wash tub is totally stainless steel as is the impeller. The wash pump itself is totally integral with the motor. Wash water is recirculated from the wash tank through the manifolds and wash arm system at the rate of 270 GPM.

**PREWASH PUMP MOTOR:** A 2 HP totally enclosed, fan cooled type motor drives the prewash pump and arms. Single-phase motors are capacitor start, induction run with internal thermal overload protection. Three-phase motors are induction run with external overload protection. Motor shaft is supported by permanently lubricated grease packed ball bearings.

**WASH PUMP MOTOR:** A 2 HP totally enclosed, fan cooled type motor drives the wash pump and arms. Single-phase motors are capacitor start, induction run with internal thermal overload protection. Three-phase motors are induction run with external overload protection. Motor shaft is supported by permanently lubricated grease packed ball bearings.

**CONVEYOR SYSTEM:** Racks are conveyed through the machine by a center-mounted, heavy-duty stainless steel pawl bar with stainless steel cast, counter-weighted, wide surface pawls. The pawl bar is designed to not interfere with spray patterns in the prewash, wash, and rinse section. The pawl bar is driven by a 1/4 HP motor and worm drive gear reduction unit. The conveyor motor itself is totally enclosed, non-ventilated. Single-phase motors are capacitor start, induction run with internal thermal overload protection. Three-phase motors are induction run with external overload protection. Pawl bar conveyor drive unit is mounted on the left hand side of the machine and is enclosed with a removable stainless steel cover. Maximum conveyor speed is 7.5 feet per minute.

**ADJUST-A-PEAK:** The Adjust-A-Peak feature is a mechanical feature located on the pawl bar drive unit itself and allows the end-user to slow down the speed of the conveyor drive unit when enhanced results are required (i.e. baked-on food soil) or increase the speed of the conveyor drive unit when maximum capacity is required. By slowing down the conveyor, a rack of tableware remains in the prewash, wash, and rinse sections for longer periods of time. When soil loads are heavy (i.e. pots and pans, trays, and bun pans), adjusting the conveyor to slower speeds means outstanding results.

**CHAMBER:** The chamber has a standard clearance of 25" which is the highest clearance in the industry—even higher than competitive higher hood options. This adds to the versatility of the machine since you can easily accommodate larger utensils such as sheet pans and 60 quart mixing bowls. The combination of a higher hood in conjunction with manually slowing down the conveyor utilizing the Adjust-A-Peak feature produces superior results as well as adding to the versatility of the machine.

**CONTROLS:** Controls are located in a stainless steel control box mounted on top of the machine for ease of access and increased reliability. Power "ON/OFF" switch is the only manual switch required. "Energy Guard" fully automates the machine and utilizes switching logic to operate prewash, wash, and rinse sections only when a rack is in place as well as turning the conveyor off when a rack exits the machine and there are no other racks in the machine. Regardless of machine voltage, all control circuitry will be operated from a 110 volt control circuit transformer. Again, the Adjust-A-Peak feature eliminates the need for manual controls since you have the ability to slow down the conveyor for extended prewash, wash, and rinse contact time. The unit is completely wired with 105°C, 600V thermoplastic insulated wire and routed through UL approved conduit. The control circuit itself is protected by a manual reset 1 AMP overload protector located on the front of the control box.

**FILL:** Initial fill of the prewash tank and the wash tank is automatic when machine is initially energized. There are separate fills to each tank and each is controlled by its own standard solenoid valve and vacuum breaker assembly. The prewash tank needs to be hooked up to a water line capable of filling with 110-140°F incoming potable water rather than filling with 180°F from the booster heater through the wash tank as does the competition. If the cold water thermostat option is utilized in the prewash, an additional cold water line needs to be hooked up to the machine. The wash tank fill line needs to be hooked up to a 180°F minimum incoming potable water line which normally would be supplied by an external booster heater or our own optional Hatco booster heater packages. The fill solenoids for both tanks are activated by stainless steel float systems located in the individual tanks for required maintenance of tank water levels.

**RECIRCULATING PREWASH:** The prewash tank itself has a 16.0 gallon capacity and maintains that level with a skimming type overflow. Prewashing action is accomplished by recirculating 110-140°F water through 20 separate stripping nozzles through three upper arms and two lower arms. This superior action removes heavy soil and deposits it in a large outside deep well scrap basket located on the front of the machine for easy access. A secondary removable pump intake strainer protects the pump itself. Make-up water comes from the wash at the rate of approximately 2 GPM. All five wash arms are easily removable and along with removable prewash arm end caps, are easily cleanable without the use of tools.

**RECIRCULATING WASH:** The wash tank has a 20.4 gallon capacity and maintains that level with a skimming type overflow that flows excess wash water into the prewash tank. Washing action is accomplished by recirculating detergent laden wash water in the wash tank through upper and lower wash arms. Make-up water comes from the final rinse section and is controlled at approximately 2 GPM. The arms themselves are extended and create a longer wash section than competitive models. Wash section is automatically activated by racks as they pass through. Wash arms, upper and lower, contain 43 separate stripping nozzles for superior performance. Both wash arms are easily removable and along with removable wash arm end caps, are easily cleanable without the use of tools. Large stainless steel strainer pans as well as a pump intake strainer for secondary protection are readily accessible and removable for cleaning purposes. Knockouts and connections are provided to allow easy installation of detergent concentration sensor and dispenser tubing by others.

**FINAL RINSE:** Fresh pressurized rinse water enters the machine through a standard "Y" strainer, solenoid valve, and approved vacuum breaker assembly and is plumbed to upper and lower final rinse arms located at the output end of the machine. Single rows of fan jet nozzles are located on both rinse arms. Connection points are provided for both rinse agent injection and sodium hypochlorite (low-temp chemical sanitizing machines only) into the final rinse line by others. Total final rinse flow rate is 4.7 GPM.

**DRAIN, OVERFLOW, AND MAKE-UP:** The machine is designed to maintain appropriate prewash and wash tank water levels at all times even at low pressures. The overflow system is designed to automatically skim the surface of both tanks. Make-up water from the final rinse system not only replenishes the wash water but also helps maintain appropriate water levels as well as appropriate wash tank temperatures. Large levers located on the front panel of the machine operate drain valves and prewash and wash tanks completely.

**PRESSURE REDUCING VALVE:**

Factory installed on incoming water line to control water pressure.

**Additional Standard Equipment:**

- Vent cowls/splash shields with 4" x 16" openings covered with removable plates for connection to exhaust ducts when required.
- Flexible NSF approved strip curtains provided at the ends of the vent cowls as well as at the ends of the machine and separating the prewash, wash, and final rinse compartments.
- Extra large inspection doors located on front of the machine for easy access and cleanability and requiring only one hand operation.
- Safety door switches shut down the machine should either door be opened during operation.
- Stainless steel front appearance panel.
- Positive low level water protection for wash tank heat.
- Sealed dial type thermometers for prewash, wash, and rinse temperatures.

**Optional Mandatory Specifications:**

**Wash Tank Heating Equipment (Choose One):**

**ELECTRIC:** Low watt density 20 KW tubular heating element mounted inside the wash tank and easily removable from the outside. The heater is protected by a stainless steel float system as well as high limit overload protection. Tank water temperature is controlled and maintained by a fast reacting thermostat which controls the heating element.

**STEAM:** Stainless steel coils are utilized rather than injectors so that contaminated steam being injected into the water is not an issue. Stainless steel tubular steam coils are mounted inside the wash tank below the optimum water level. The coils are protected by a stainless steel float system. An external steam "Y" strainer and high temperature steam solenoid regulates the flow of

steam through the coil. Tank temperature is controlled and maintained by a fast reacting thermostat which controls the operation of the steam solenoid. A float and thermostatic steam trap is provided and removes steam condensate from the steam coils which can either be plumbed to a drain or pumped back to the boiler if a condensate return system is available. Steam coils require a minimum of 10 PSIG flowing steam supply and a maximum of 20 PSIG. Install with a steam pressure regulator (by others) if steam supply exceeds 20 PSIG.

**Optional Features and Accessories:**

**EXTERNAL 40°F ELECTRIC BOOSTER HEATER:**

External Hatco booster heater boosts incoming 140°F water to a minimum of 180°F for hi-temp sanitizing rinse. Custom features include castone-lined tank, low water cutoff, pressure relief valve, as well as a pressure reducing valve. Unit is located on the right hand side of the machine, completely plumbed in, and with the controls circuitry completely interwired to the dishwasher. Power to the booster heater requires a separate electrical connection. Unless specified otherwise, electrical characteristics of the booster heater will be the same as that of the dishwasher. The booster heater is optional and available on 208/240/460 voltages/3 phase machines only.

**EXTERNAL 70°F RISE BOOSTER HEATER:**

(1) 54 KW Hatco booster heater capable of boosting incoming 110°F water a minimum of 70°F to a minimum of 180°F for hi-temp sanitizing rinse. Unit is located on the right hand side of the machine and comes completely preplumbed. Power to the booster heater requires a separate electrical connection. Unless specified otherwise, electrical characteristics of the booster heater will be the same as that of the dishwasher. The external booster heater is available in 208/240/480 voltages/3 phase only.

**STEAM BOOSTER HEATER:**

Sized to be connected to a standard 140°F incoming water supply in order to insure 180-195°F hi-temp sanitizing final rinse requirements. Unit comes complete with steam "Y" strainer and high temperature steam solenoid as well as a steam pressure relief valve. Water temperature is controlled and maintained by a fast reacting thermostat which controls the operation of the steam solenoid. A float and thermostatic steam trap is provided and removes steam condensate from the coil which can either be plumbed to a drain or pumped back to a boiler if a condensate return system is available. Must be installed with a steam pressure regulator (by others) if steam supply exceeds 20 PSIG.

**TABLE LIMIT SWITCH:** Factory wired to machine and mounted to the backsplash of the table in the field. Prevents damage to conveyor drive system, racks, and dishes due to racks backing up on the output end of the machine. Highly recommended for clean dishtables less than 10 feet in length.

**VENT COWL COLLARS:** Factory installed 16" x 7" high collars located on the vent cowls to allow easy connection to an external exhaust system including a standard "pant-leg" type exhaust duct. Includes adjustable and lockable damper flap for fine tuning exhaust system to remove appropriate CFM requirements.

**50 CYCLE (HERTZ) ELECTRICAL CHARACTERISTICS:**

Units are available in 50 HZ in the following voltages: 208V/1 or 3PH, 230V/1 or 3PH, 380V/3PH, and 460V/3PH. Units operating at 50 HZ are not submitted for UL Listing.

**COLD WATER THERMOSTAT:** Provides an accurate method of controlling prewash tank heat to prevent "baking on" food soil in the prewash section. This feature is especially valuable for high protein soil loads such as eggs and cheese.

**SIDELOADER:** Factory installed option on input end of conveyor machine. This feature allows the machine to be installed close to a corner and maximize dishroom space. The sideloader option is available in both the hooded and unhooded versions. See separate spec sheets for details.

**EXHAUST VENT FAN CONTROL:**

Automatically turns exhaust vent fan on when rack enters the machine. Delay timer also turns off the exhaust vent fan 5-10 seconds after rack exits machine when no other racks are being conveyed through the machine.

**FLANGED FEET:**

Available for installations where permanent mounting to the floor is required. Fully adjustable for required height.

**WATER HAMMER ARRESTOR:**

Installed inside the supply line.

# AJ-90 Vision Series

# Conveyors

## Specifications

Note: Check and/or copy all that apply.

**AJ-90 Series Rack Conveyor Dishwasher – Item No.** \_\_\_\_\_

Shall be a Jackson AJ-90 Series, single tank rack conveyor dishwasher with 36" prewash. Sanitization shall be accomplished by using hi-temp (180°F minimum) sanitizing rinse.

Electrical characteristics shall be:

_____ 208V/60HZ/3PH	_____ 208V/50HZ/3PH
_____ 208V/60HZ/1PH	_____ 208V/50HZ/1PH
_____ 230V/60HZ/3PH	_____ 230V/50HZ/3PH
_____ 230V/60HZ/1PH	_____ 230V/50HZ/1PH
_____ 460V/60HZ/3PH	

Wash tank heating shall be a minimum of 160°F for hi-temp applications and accomplished by:

\_\_\_\_\_ (2) 10 KW (total 20 KW) electric heating elements thermostatically controlled.

\_\_\_\_\_ Stainless steel steam coils thermostatically controlled.

Direction of rack flow shall be (when standing in front of machine):

\_\_\_\_\_ Right-to-Left      \_\_\_\_\_ Left-to-Right

## Unit shall have the following features as optional extras:

\_\_\_\_\_ External Hatco 36 KW booster heater for a minimum 40°F rise and available in the following voltages:

\_\_\_\_\_ 208V/50 or 60HZ/3PH  
\_\_\_\_\_ 240V/50 or 60HZ/3PH  
\_\_\_\_\_ 480V/50 or 60HZ/3PH

\_\_\_\_\_ External Hatco (1) 54 KW booster heater for a minimum 70°F rise and available in the following voltages:

\_\_\_\_\_ 208V/50 or 60HZ/3PH  
\_\_\_\_\_ 240V/50 or 60HZ/3PH  
\_\_\_\_\_ 480V/50 or 60HZ/3PH

\_\_\_\_\_ Steam booster heater.

\_\_\_\_\_ Table limit switch completely prewired and extending from the output end of the machine, available in 9'0" length.

## Unit shall have the following features:

- Capacity of 270 racks per hour utilizing 1.03 gallons of water per rack for hi-temp sanitizing rinse.
- Incoming water pressure regulator.
- Adjust-A-Peak conveyor drive system to manually adjust rack capacity of the machine.
- Minimum 25" clearance throughout machine.
- Energy Guard controls system which prewashes, washes, rinses and conveys a rack through the machine only when a rack is in place.
- Completely electro-mechanical; no solid-state controls.
- Fully automatic operation including auto-fill.
- Prewash section shall have 3 upper arms and 2 lower arms as well as a 2 HP pump.
- Prewash must have separate fill line rather than filling through the wash tank from the booster heater with 180°F heated water.
- Prewash pump, wash pump, and the impellers completely of stainless steel and self-draining.
- Wash section must be a minimum of 23" in length as well as 23" separation between recirculating wash and final rinse.
- Convenient, externally operated lever drains.
- Vent cowls/splash shields with extra curtains on both prewash and rinse ends of the machine.
- Stainless steel frame, legs, adjustable bullet feet, and front appearance panel.
- All 304 series stainless steel construction; no. 400 series stainless steel and no plastics utilized.

\_\_\_\_\_ Table limit switch completely prewired and extending from the output end of the machine, available in 12'0" length.

\_\_\_\_\_ Table limit switch completely prewired and extending from the output end of the machine, available in 15'0" length.

\_\_\_\_\_ Installed 4" x 16" x 7" high vent cowl collars for easy connection to an external exhaust system and including adjustable and lockable damper flaps.

\_\_\_\_\_ output end only      \_\_\_\_\_ input end only  
\_\_\_\_\_ both ends

\_\_\_\_\_ Incoming water hammer arrestor completely installed.

\_\_\_\_\_ Sideloader installed on input end of machine.

\_\_\_\_\_ unhooded sideloader      \_\_\_\_\_ hooded sideloader

\_\_\_\_\_ Exhaust fan control controls external exhaust fan power and duration time.

\_\_\_\_\_ Flanged feet for permanent in-place mounting to the floor.



07610-002-66-76

All specifications subject to change without notice.

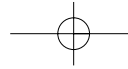

# AJ-90 Vision Series



## Left to Right Operation Shown

### Legend to Drawing

- A** - 3/4" F.N.P.T. water inlet, 66 1/2" a.f.f. 180°F water min. hi-temp unit, minimum flow requirements 4.7 GPM, 279 GPH.
- B** - 3/4" F.N.P.T. prewash water inlet, 66 1/2" A.F.F. 140°F water max.
- C** - 1 1/2" f.n.p.t. drain connection 9" A.F.F.
- D** - Electrical connection 67" A.F.F. (Does not include booster heater).
- E** - Vent cowl - standard both ends.
- F** - Optional vent collar with damper, 4" wide x 16" long x 7" high - supplied at additional cost.
- G** - 3/4" F.N.P.T. low pressure steam connection - optional tank heat. Supplied with gate valve. requires 60 lbs of steam per hour (1.74 BHP).
- H** - 3/4" N.P.T. condensate return connection. Return to boiler feeder or open drain.
- J** - 3/4" F.N.P.T. coldwater thermostat plumbing.

### Notes:

- All vertical dimensions are +/- 1/2" from floor due to adjustable bullet feet
- Maximum overall dimension of unit is 34 1/2", which includes trash box and drain piping. Minimum door opening required 35" wide x 78" high.

### Approximate Total Load Amps

AJ-90 Series Electrical Data	Electric Tank Heat		Steam Tank Heat	
	1-PH	3-PH	1-PH	3-PH
208 Volts 60 Cycles	114.8	67.9	18.8	12.3
230 Volts 60 Cycles	105.8	62.6	18.8	12.3
460 Volts 60 Cycles	N/A	30.8	N/A	6.9

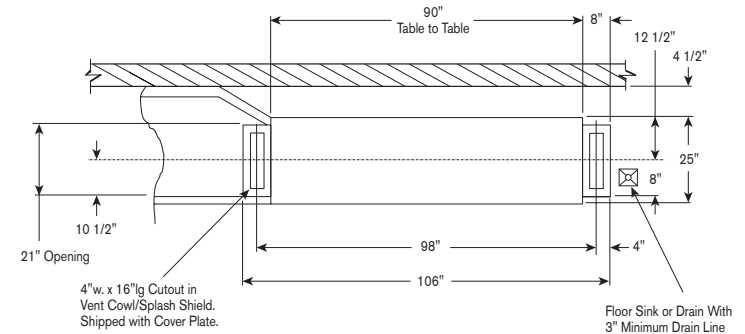

### Recommended Table Fabrication

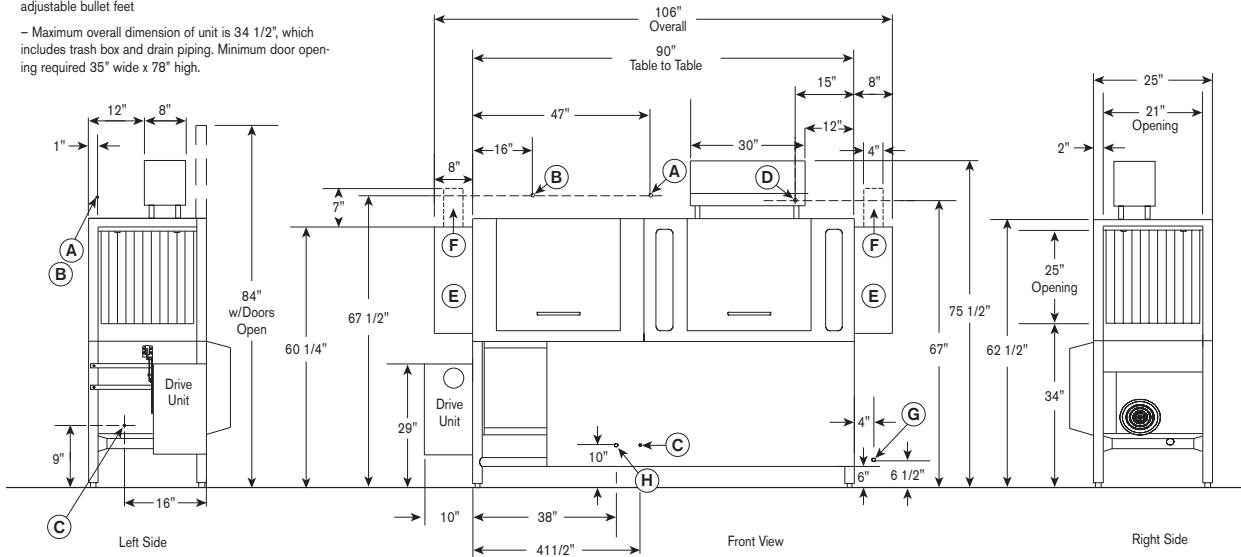
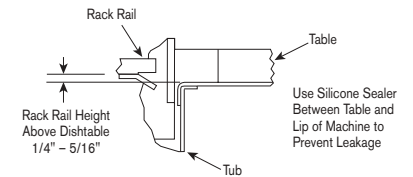

Note: Tub Will Accept a Table Flange Up to 24 7/8"

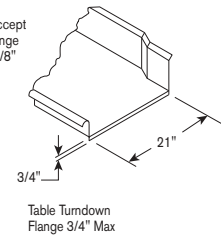
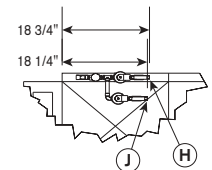
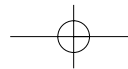

Table Turndown Flange 3/4" Max



Prewash Plan View Section With Cold Water Thermostat





# AJ-90 Vision Series

## Right to Left Operation Shown

### Legend to Drawing

- A** - 3/4" F.N.P.T. water inlet, 66 1/2" a.f.f. 180°F water min. hi-temp unit, minimum flow requirements 4.7 GPM, 279 GPH.
- B** - 3/4" F.N.P.T. prewash water inlet, 66 1/2" A.F.F. 140°F water max.
- C** - 1 1/2" f.n.p.t. drain connection 9" A.F.F.
- D** - Electrical connection 67" A.F.F. (Does not include booster heater).
- E** - Vent cowl - standard both ends.
- F** - Optional vent collar with damper, 4" wide x 16" long x 7" high - supplied at additional cost.
- G** - 3/4" F.N.P.T. low pressure steam connection - optional tank heat. Supplied with gate valve. requires 60 lbs of steam per hour (1.74 BHP).
- H** - 3/4" N.P.T. condensate return connection. Return to boiler feeder or open drain.
- J** - 3/4" F.N.P.T. coldwater thermostat plumbing.

### Notes:

- All vertical dimensions are +/- 1/2" from floor due to adjustable bullet feet
- Maximum overall dimension of unit is 34 1/2", which includes trash box and drain piping. Minimum door opening required 35" wide x 78" high.

### Approximate Total Load Amps

AJ-90 Series Electrical Data	Electric Tank Heat		Steam Tank Heat	
	1-PH	3-PH	1-PH	3-PH
208 Volts 60 Cycles	114.8	67.9	18.8	12.3
230 Volts 60 Cycles	105.8	62.6	18.8	12.3
460 Volts 60 Cycles	N/A	30.8	N/A	6.9

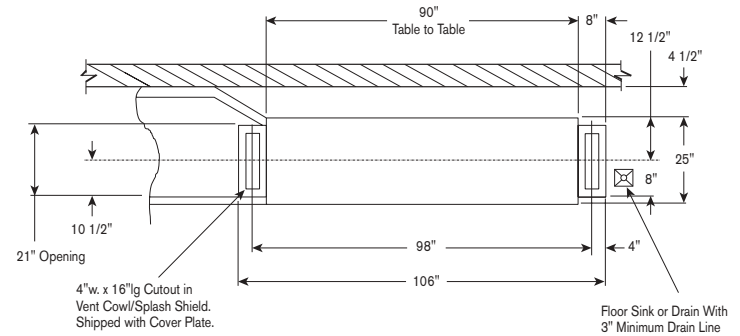

### Recommended Table Fabrication

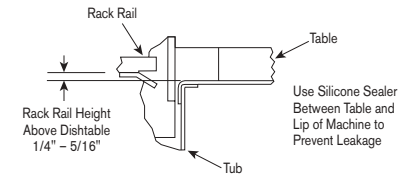

Note: Tub Will Accept a Table Flange Up to 24 7/8"

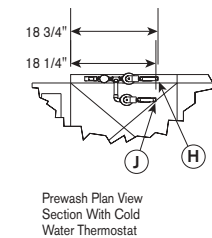
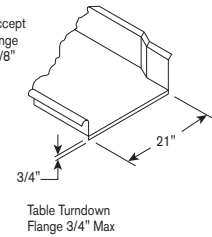

07610-002-86-77  
All specifications subject to change without notice.

