

Lincoln®



Pizzaovens.com

1.877.FOR.OVEN
367.6836

Since 1999

Impinger® III Series Dual Belt Conveyorized Electric Oven

Model No. 1202
Model No. 1203
Model No. 1228
Model No. 1229



Ovens shown are Single & Double Oven systems with top, stand and accessories.



Approved by The Canadian Gas Association

FEATURES:

AIR IMPINGEMENT allows for rapid heating, cooking, baking and crisping of foods, two to four times faster than conventional ovens, depending on food product cooked. Uniform heating/cooking of food products offers a wide tolerance for rapid baking at a variety temperatures. Variable speed system moves products through the oven one after the other, improving product flow during cooking and virtually eliminating labor. Safety of conveyorized product movement is a definite advantage over batch type ovens as it allows selftending of the product.

Oven has self-contained heating system. Heating on top and bottom can be controlled by zoning. Lincoln Impinger® Series Conveyorized Electric Oven Model **No.1202,1203,1228,1229** is shown with accessories as specified. **One stand is used as insulation for bottom of oven, and one top must be specified.**

GENERAL: Electric Baking/Finishing Oven is self-contained, conveyorized and stackable (Max. (2) high). Temperature is adjustable from 300°F (149°C.) to 600°F (316°C.), and conveyor speed is adjustable from 50 seconds to 30 minutes cooking cycle. Doors have access opening with see-through window to allow product to be placed on the moving conveyor inside the baking chamber when a shorter cook cycle is desired. Conveyor and air distribution fingers are easily removable for cleaning.

CONSTRUCTION: Exterior is fabricated from No. 4 finish stainless steel. The air distribution system consists of a radial type fan powered by a $\frac{1}{8}$ HP, AC Motor. The heated air is forced through eight (8) distribution fingers located in the baking chamber with four (4) above the conveyor belt and four (4) below. Each finger has 90 $\frac{1}{16}$ " (11 mm) diameter holes to create the air impingement effect on the food product passing through the baking chamber on the conveyor belt. The conveyor consists of two flexible stainless steel belts, 15" (381 mm) wide with a travel distance of 72" (1829 mm), of which 35 $\frac{3}{8}$ " (908 mm) is in the baking chamber. The conveyors are powered by two stepper motors and gear reduction assemblies. For installations requiring belt travel in the opposite direction, a switch on the conveyor is repositioned. Heat is supplied by (6) elements at 4500 watts each. The control panel is located at the right rear of oven and has power on-off switch, temperature control, conveyor control for each belt, thermostat indicator light, conveyor selection switch and fuses for the controls and the blower motor. LED readouts display oven temperature and conveyor belt speed in minutes and seconds of time. Drip pans are located below the conveyor belt both inside and outside the baking chamber.

Impinger® III Dual Belt Conveyorized Electric Oven

Model Nos. 1202, 1203, 1228, 1229

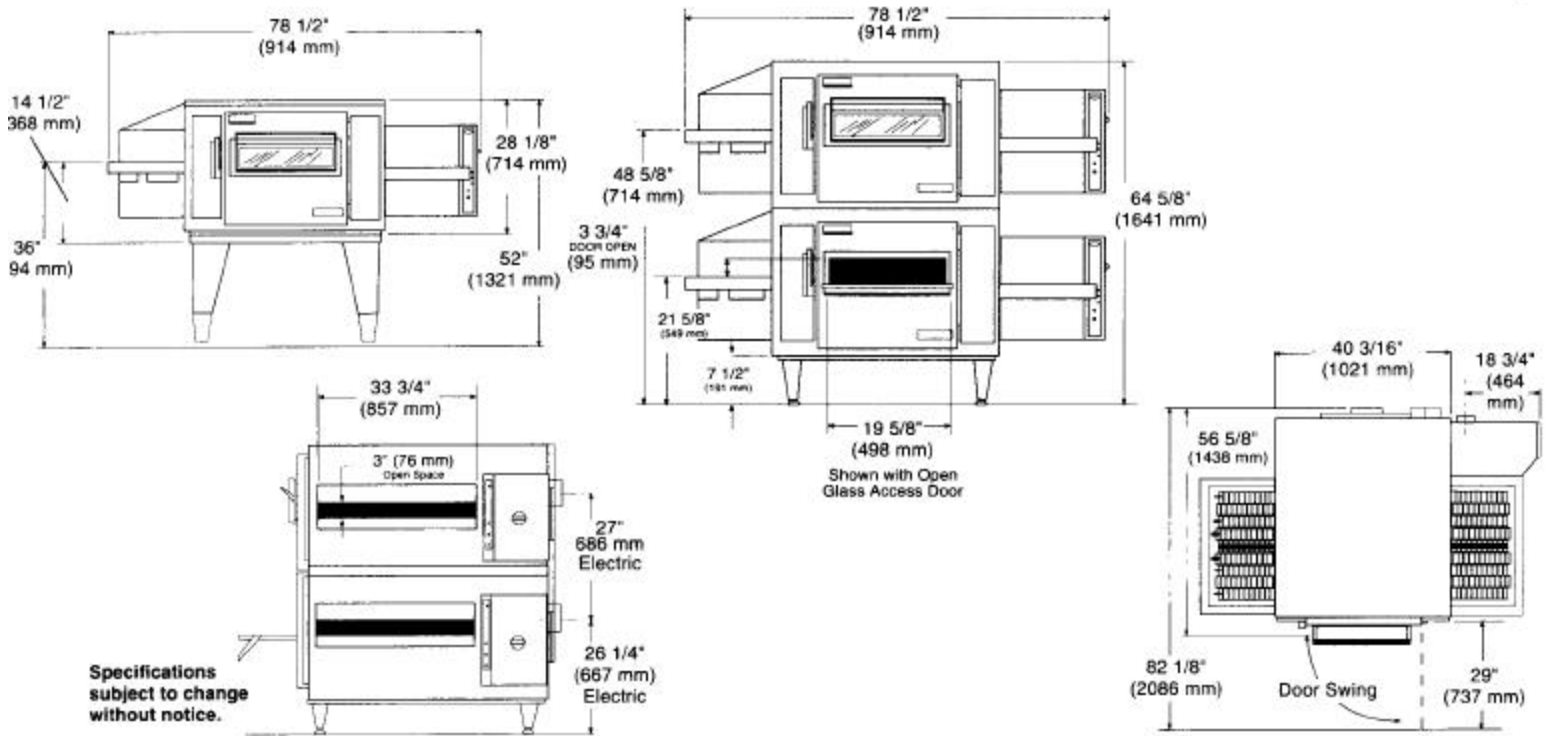

GAS

TESTING AGENCY LISTING	CAT. NO.	W (in.)	D (in.)	H SINGLE STACK (in.)	H DOUBLE STACK (in.)	VOLTS	AMPS	KW	PHASE	Hz	SUPPLY
U.L./CGA	1202	78 1/2	56 5/8	52	64 5/8	120/208	80	27	3	60	5 WIRES
U.L./CGA	1203	78 1/2	56 5/8	52	64 5/8	120/240	70	27	3	60	5 WIRES
--	1228	78 1/2	56 5/8	52	64 5/8	380Y/220V	41	27	3	50	5 WIRES
--	1229	78 1/2	56 5/8	52	64 5/8	415Y/220V	38	27	3	50	5 WIRES

Metric Dimensions for all models: Width: 1994 mm; Depth: 1438 mm; Height Single Stack: 1321 mm; Height Double Stack: 1641 mm NOTE: If double-stacked, each oven must be wired separately to carry rated load. Each oven requires a "dedicated neutral". U.S. Patent Nos. 3,844,213-4,154,861-4,462,383 and other patents pending.

UTILITY SPECIFICATIONS REQUIRED ELECTRICAL SERVICES: Each oven deck requires voltage, phase and hertz as indicated by model no., 5-wire supply [3 poles + neutral + ground], (independent earth ground whenever possible). **VENTILATION: A VENT IS REQUIRED:** Local codes prevail. These are the "authority having jurisdiction" as stated by the NATIONAL FIRE PROTECTION ASSOCIATION, INC. in NFPA 96-latest edition. A ventilation hood is required to remove heat, cooking odors and products of combustion. The hood and HVAC installation must meet local codes to gain approval by the authority having jurisdiction. The ventilation hood must operate in harmony with the building HVAC system. It typically requires between 1200 and 3500 CFM exhaust. (The "efficiency" of various hood designs makes it necessary to specify such a wide range of ventilator CFM). Make-up air must be supplied by either a hood design or the HVAC system. **CAUTION: Prevent airflow through the cooking tunnel. Air must not be directed onto oven front or at the side of cooking area or rear of oven.** In all cases, the ambient temperature around the oven must be less than 95°F (35°C.) when the oven is operating. In certain localities, other chemical or gaseous methods of detecting adequate capture will be the requirements to meet for the local code authority. NOTE: Refer to Installation and Operations Manual for additional requirements. **SPACING:** The oven must have 6" (127 mm) of clearance from combustible surfaces. A permanently installed oven requires approximately 11 ft. (3553 mm) of clearance overall to allow for removal of the conveyor and protective guards for cleaning. The conveyor is removed from the control side of the oven. If other cooking equipment is located on the right side of the Impinger® oven, a minimum clearance of 24" (609 mm) is required from that



Pizzaovens.com

1.877.FOR.OVEN
367.6836

Since 1999



Note: following components - minimum requirement:

- 1 - Oven (or two for double-stack ovens)
- 1 - 1009 Top (for either single oven or double-stack ovens)
- 1 - Stand (high for single oven; low for double-stack ovens)
- 8 - Columnating Panels (16 for double-stack ovens)

For additional components, See Form #889, "Impinger® I and Impinger® III Components and Accessories."



1111 N. Hadley Rd., FO. Box 1229
Fort Wayne, IN 46801 • (219) 432-9511
(800)374-3004
FAX: (219)436-0735

Litho in U.S.A.
©1998 Lincoln Foodservice Products, Inc.
Form #896-1M 5/98-1