

Lincoln®



Pizzaovens.com

1.877.FOR.OVEN
367.6836

Since 1999

Impinger® I Series Single Belt Conveyorized Gas Fired Oven

Model No. 1040
Model No. 1041
Model No. 1042
Model No. 1043
Model No. 1046
Model No. 1047

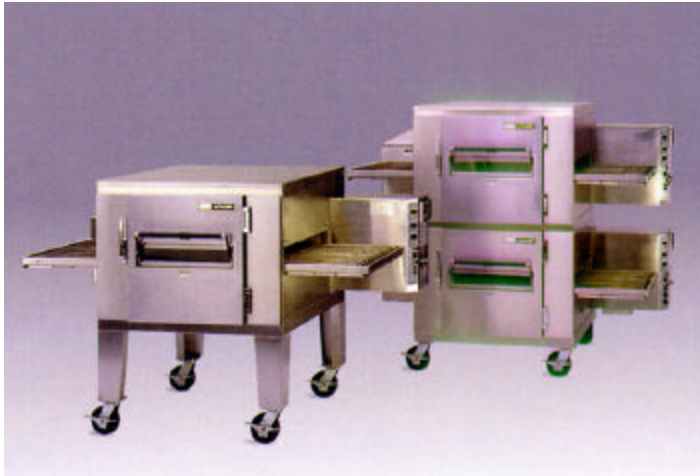

Ovens shown are Single & Double Oven systems with top, stand and accessories.



Approved by The Canadian Gas Association
Approved by The Australian Gas Association

FEATURES:

AIR IMPINGEMENT allows for rapid heating, cooking, baking and crisping of foods, two to four times faster than conventional ovens, depending on food product cooked.

Uniform heating/cooking of food products offers a wide tolerance for rapid baking at a variety of temperatures.

Variable speed system moves products through the oven one after the other, improving product flow during cooking and virtually eliminating labor.

Safety of conveyorized product movement is a definite advantage over batch type ovens as it allows selftending of the product.

Oven has self-contained heating system. Heating on top and bottom can be controlled by zoning.

Lincoln Impinger® Series Conveyorized Gas Fired Oven Model **No.1040,1041,1042,1043,1046,1047**, is shown with accessories as specified. **One stand is used as insulation for bottom of oven, and one top must be specified.**

GENERAL: Gas Fired Baking/Finishing Oven is selfcontained, conveyorized and stackable (Max. (2) high). Temperature is adjustable from 300°F. (149°C.) to 600°F (316°C.), and conveyor speed is adjustable from 50 seconds to 30 minutes cooking cycle. Doors have access opening with see-through window to allow product to be placed on the moving conveyor inside the baking chamber when a shorter cook cycle is desired. Conveyor and air distribution fingers are easily removable for cleaning.



CONSTRUCTION: Exterior is fabricated from No. 4 finish stainless steel. The air distribution system consists of a radial type fan powered by a 1/3 HP, AC Motor. The heated air is forced through eight (8) distribution fingers located in the baking chamber with four (4) above the conveyor belt and four (4) below. Each finger has 90 - 7/16" (11 mm) diameter holes to create the air impingement effect on the food product passing through the baking chamber on the conveyor belt. The conveyor belt is flexible stainless steel, 32" (813 mm) wide with a travel distance of 72" (1829 mm), of which 35 3/4" (908 mm) is in the baking chamber. The conveyor is powered by a stepper gear motor with reversing possible on motor control board for installations requiring opposite belt travel. Heat is supplied by a power burner rated at 120,000 BTU/Hr. , with electronic ignition. Gas control system has a manual shut-off valve, internal pressure regulator (factory preset at 3 1/2 inches water column / 87 kPa or 8.7 mbar for Natural Gas, 10 inches water column / 2.48 kPa or 24.87 mbar for LP gas), and an electric solenoid operated main gas valve. The control panel is located at the right rear of oven and has power on-off switch, burner on-off switch, conveyor on-off switch, temperature control, conveyor control, thermostat indicator light, and fuses for the conveyor motor and the blower motor located in the rear. LED readouts display oven temperature and conveyor belt speed in minutes and seconds of time. Drip pans are located below the conveyor belt both inside and outside the baking chamber.

Impinger® I Single Belt Conveyorized Gas Oven

Model Nos. 1040, 1041, 1042, 1043, 1046, 1047

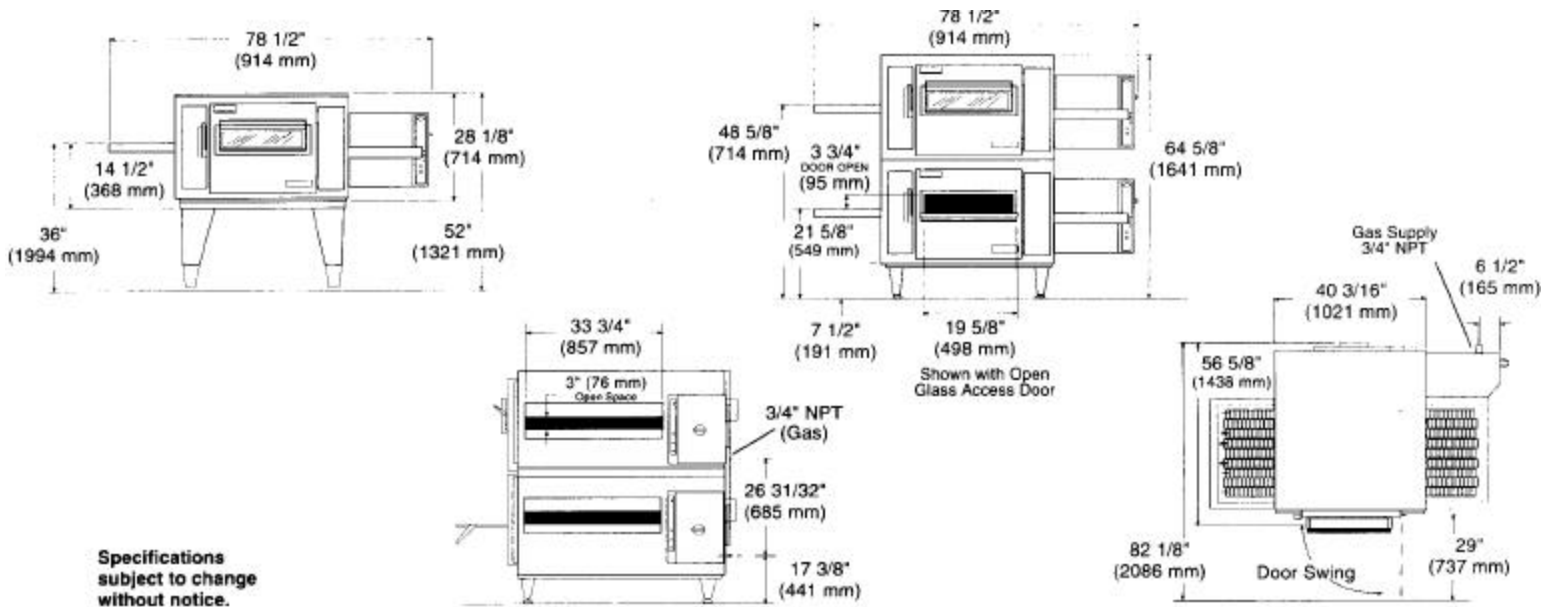

Specifications subject to change without notice.

TESTING AGENCY LISTING	CAT. NO.	GAS		H		GAS TYPE	INPUT RATE CAPACITY PER HOUR	VOLTS	AMPS	PHASE	Hz	SUPPLY
		W (in.)	D (in.)	SINGLE STACK (in.)	DOUBLE STACK (in.)							
AGA/CGA	1040	78/2	565/8	52	645/8	NATURAL	120,000 BTU/Hr.	120/240	5	1	60	4 WIRE
AGA /CGA	1041	78/2	565/8	52	645/8	L. P.	120,000 BTU/Hr.	120-240	5	1	60	4 WIRE
-	1042	78/2	565/8	52	645/8	NATURAL	120,000 BTU/Hr.	240	5	1	50	3 WIRE
-	1043	78/2	565/8	52	645/8	LP	120,000 BTU/Hr.	240	5	1	50	3 WIRE
AGA/Australia	1046	78/2	565/8	52	645/8	NATURAL	126 MJ	240	5	1	50	3 WIRE
AGA/Australia	1047	78/2	565/8	52	645/8	LP.	126 MJ	240	5	1	50	3 WIRE

Metric Dimensions for all models: Width: 1994 mm; Depth: 1438 mm; Height Single Stack: 1321 mm; Height Double Stack: 1641 mm

NOTE: If double-stacked, each oven must be wired separately to carry rated load. Each oven requires a "dedicated neutral". U.S. Patent pending.

UTILITY SPECIFICATIONS REQUIRED

GAS SERVICE: Each oven deck requires 120,000 BTU/Hr.

Natural gas requires 7" WC/1.7 kPa or 17.4 mbar inlet with maximum allowable of 14.5" WC/3.6 kPa or 36.05 mbar. LP gas requires 11" WC/2.7 kPa or 27.36 mbar inlet with maximum allowable of 14.5" WC/3.6 kPa or 36.05 mbar.

Gas line from meter to ovens should be sufficient to insure full volume flow of gas to ovens.

AGA/CGA design approved flexible connection to each oven must be 3/4" NPT and length must not exceed 6 ft. (1524 mm).

ELECTRICAL SERVICES: Each oven deck requires voltage, phase and hertz as indicated by model no., 3-wire supply [1 pole + neutral + ground], (independent earth ground whenever possible); 4-wire supply [2 pole + neutral + ground], (independent earth ground whenever possible).

NOTE: It is recommended that a separate 20 amp - 2 pole circuit breaker be provided for each oven deck.

A VENT IS REQUIRED: Local codes prevail. These are the "authority having jurisdiction" as stated by the NATIONAL FIRE PROTECTION

ASSOCIATION, INC. in NFPA 96-latest edition. A ventilation hood is required to remove heat, cooking odors and products of combustion. The hood and HVAC installation must meet local codes to gain approval by the authority having jurisdiction.

The ventilation hood must operate in harmony with the building HVAC system. It typically requires between 1200 and 3500 CFM exhaust. (The "efficiency" of various hood designs makes it necessary to specify such a wide range of ventilator CFM). Make-up air must be supplied by either a hood design or the HVAC system.

CAUTION: Prevent airflow through the cooking tunnel. Air must not be directed onto oven front or at the side of cooking area or rear of oven.

In all cases, the ambient temperature around the oven must be less than 95°F. (35°C.) when the oven is operating. NOTE: Refer to Installation and

Operations Manual for additional requirements.

SPACING: The oven must have 6" (152 mm) of clearance from combustible surfaces. A permanently installed oven requires approximately 11 ft. (3553 mm) of clearance overall to allow for removal of the conveyor and protective guards for cleaning. The conveyor is removed from the control side of the oven. If other cooking equipment is located on the right side of the Impinger oven, a minimum clearance of 24" (609 mm) is required from that equipment.

Note: following components - minimum requirement:

- 1 - Oven (or two for double-stack ovens)
- 1 - 1009 Top (for either single oven or double-stack ovens)
- 1 - Stand (high for single oven- low for double-stack ovens)
- 8 - Columnating Panels (16 for double-stack ovens)

For additional components, See Form #889, "Impinger® I and Impinger® III

Components and Accessories"



1111 N. Hadley Rd., PO. Box 1229 Fort Wayne, IN 46801
 (219) 432-9511
 (800)374-3004
 FAX: (219) 436-0735
 c1995 Lincoln Foodservice Products, Inc.



Litho in U.S.A