

## Direct Gas Fired Conveyor Oven



PS360EWB Single Unit



PS360EWB-D Double Unit

### Principle

Middleby Marshall PS Series Conveyor ovens bake both faster and at a lower temperature than other ovens. Patented vertical columns of hot air move heat aerodynamically instead of using high temperatures. The streams of hot air remove the boundary layers of cool heavy air which tend to insulate the product. This gives very rapid baking without burning. All Middleby ovens are designed to cook a multitude of products including pizza, seafood, bagels, Mexican, etc.

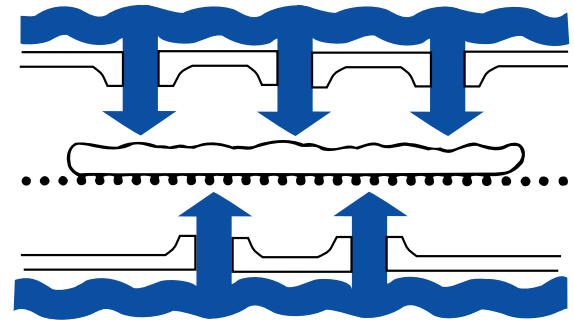

### General Information

PS360EWB conveyor ovens feature a 54.5" cooking chamber, a 44" wide conveyor belt, and a patented "Jet Sweep" convection process that delivers constant heat to the chamber. All ovens feature microprocessor controlled bake time/conveyor speed. Eight adjustable jet fingers per chamber and front-loading window are standard. Ovens have stainless steel front, sides and top. All ovens include extra fan belt, installation kit, and 4' AGA flex hose. Heating is controlled in 8" adjustable zones. Top and bottom are independently adjustable. The conveyor drive is reversible. Conveyor belt provides automatic delivery when product is finished. Front loading window with cool handle design allows product with different bake times to be cooked consistently regardless of loading.

### Special Features

PS360EWB units are stackable two high.

### Ventilation

For installation under a ventilation hood only.

### Conserves Energy

Middleby ovens provide very efficient heat transfer to product. Energy is conserved as air is recycled from heater to product, with minimum flue or vent loss.

### Cleanability

PS360EWB ovens are designed for easy cleaning. Removable parts include: crumb pans, split end panels, air fingers and a folding conveyor belt assembly for easy removal.

### Easily Serviced

Control compartment is designed for quick and easy access.

### Warranty

All PS360EWB models have a one year parts and labor warranty. Oven start-up and demonstration are included at no additional charge (USA only).

### Agency Approvals Pending

# Middleby Marshall Model PS360EWB Direct Gas Fired Conveyor Oven

Baking chamber opening: 3.875" (98.42 mm).  
Scale .25" (6.35 mm) = 1' (304.8 mm) approx.

NOTE: All Figures In Parentheses Are In Millimeters

## TOP VIEW OF BOTH THE PS360EWB SINGLE AND PS360EWB-D DOUBLE

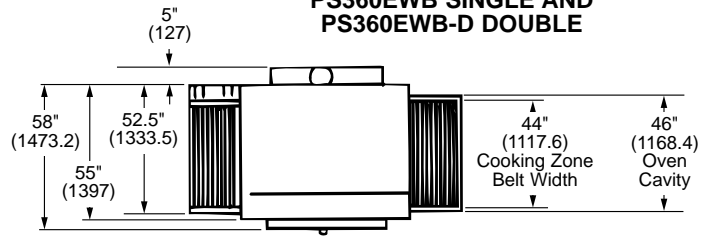

### PS360EWB SINGLE

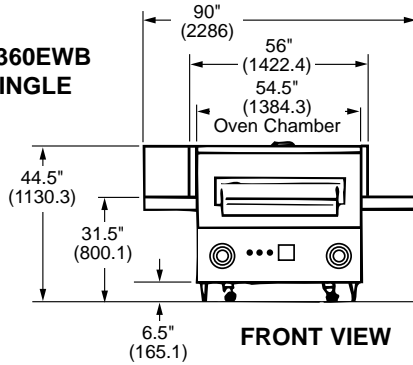

FRONT VIEW

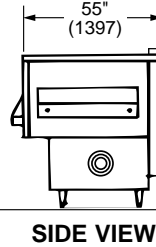

SIDE VIEW

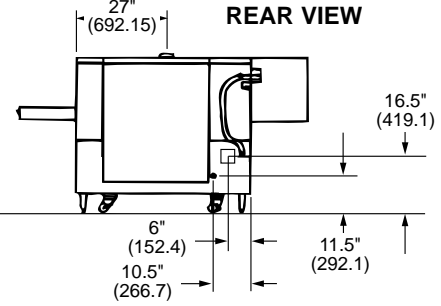

REAR VIEW

### PS360EWB-D DOUBLE

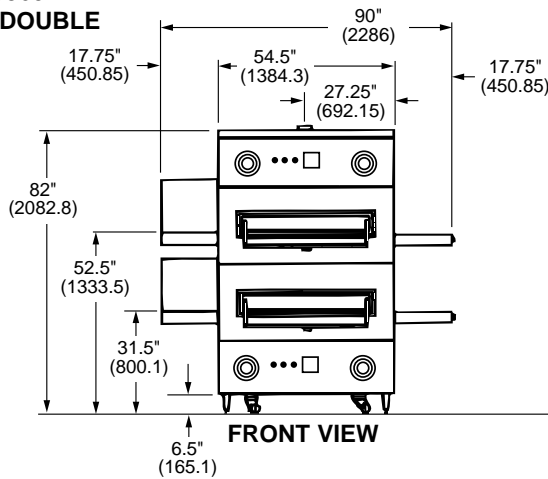

FRONT VIEW

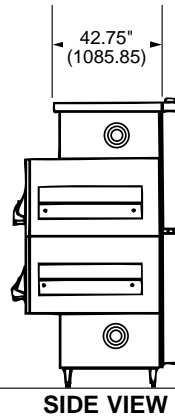

SIDE VIEW

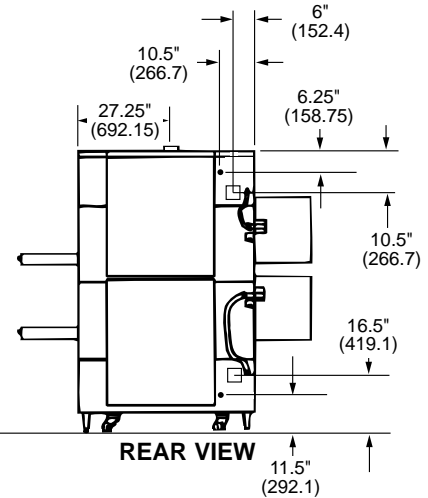

REAR VIEW

## RECOMMENDED MINIMUM CLEARANCES

Rear of Oven to Wall	Left Conveyor Extension to Wall	Right Conveyor Extension to Wall (control panel side)
1" (25.4)	0"	0"

## GENERAL INFORMATION

	Heating Zone	Bake Chamber	Belt Width	Height	Width	Depth	Max. Operating Temp.	Bake Time Range	Ship Wt. (lbs.)	Ship Cube per cavity
PS360EWB Single	54.5" (1384.3)	16.65 sq. ft. (1.546 sq. m)	44" (1117.6)	44.5" (1130.3)	90" (2286)	63" (1600.2)	550° (287°C)	2 min., 40 sec. to 29 min., 50 sec.	1675	158 ft. <sup>3</sup>
PS360EWB Double	109" (2768.6)	33.3 sq. ft. (3.093 sq. m)	44" (1117.6)	82" (2082.8)	90" (2286)	63" (1600.2)	550° (287°C)	2 min., 40 sec. to 29 min., 50 sec.	3350	158 ft. <sup>3</sup>

## GAS SUPPLY PROVIDED BY CUSTOMER

	Min. Gas Pipe Size	Gas Valves (full flow gas shut-off valve)	Req'd Supply Gas Pressure	Power
Natural Gas 1 or 2 ovens	2" (508) NPT	.75" (19.05) ID each oven	6" (152.4) to 14" (355.6) water column	170,000 BTU/HR per cavity
Propane Gas 1 or 2 ovens	1.5" (38.1) NPT	.75" (19.05) ID each oven	11.5" (292.1) to 14" (355.6) water column	170,000 BTU/HR per cavity

## ELECTRICAL RATINGS

	Voltage	Phase	HZ	Amps	Grounding	Breakers
Electric Rating (Gas Fired Ovens)	208 or 240	1	50/60	15	3 pole, 4 wire	per local codes

\* Above specifications subject to change without notice.