



LEGEND™ Single Deck Gas Pizza Ovens

Item No. _____

Project _____

Quantity _____



Model 14P-1 Shown with standard 31" (787 mm) gusset-style stainless steel clad legs.

SHORT/BID SPECIFICATIONS

Single deck oven shall be a Montague Legend *Hearth Bake* Model [Specify one]:

- 13P-1**, a 62" (1575 mm) wide unit with two gas 40,000 BTU/hr burners mounted below 41-1/2" x 31" (1054 x 787 mm) Cordierite baking hearth/deck
- 14P-1**, a 69" (1753 mm) wide unit with three gas 40,000 BTU/hr burners mounted below 48-1/2" x 36" (1232 x 914 mm) Cordierite baking hearth/deck
- 15P-1**, an 81" (2057 mm) wide unit with four gas 40,000 BTU/hr burners mounted below 60-1/2" x 36" (1537 x 914 mm) Cordierite baking hearth/deck

...with fire brick lined cooking compartment, thick blanket insulation and modulating thermostat; heavy-duty counter-weighted drop down door, satin finished stainless steel front, sides and top; plus 31" (787 mm) 12-gauge stainless steel gusset-style legs and black painted top-mounted flue deflector standard; plus all the features listed and options/accessories checked:

OVEN INTERIOR CONSTRUCTION:

- 8" (203 mm) high bake compartment
- 1-1/2" (38 mm) thick Cordierite deck for true Hearth Bake results
- Oven sides, back and top are lined with fire brick
- High temperature fiberglass blanket insulation

BURNERS & CONTROLS:

- Removable long life cast iron 40,000 BTU/hr burners with adjustable air shutters with position lock
- 300-650°F (148-343°C) burner-modulating thermostat
- Burners & standing pilot accessed through fire door with crumb ejector
- Automatic safety pilot for automatic ignition

MODEL-PRODUCTION GUIDE				CAPACITY	
Model No.	Overall Width	Deck Size	12" (305 mm)	18" (457 mm)	
13P-1	62" (1575 mm)	41-1/2" x 31" (1054 x 787 mm)	6 ea.	2 ea.	
14P-1	69" (1753 mm)	48-1/2" x 36" (1232 x 914 mm)	8 ea.	4 ea.	
15P-1	81" (2057 mm)	60-1/2" x 36" (1537 x 914 mm)	10 ea.	6 ea.	

EXTERIOR CONSTRUCTION FEATURES:

- Satin finish stainless steel front, two sides and top
- Other surfaces painted black with electrolytic zinc undercoating
- 7-3/4" (197 mm) high flue deflector standard
- Full compartment width drop-down door with aluminized steel interior
- Door is counterweighted for tight seal and easy closing (no springs)
- One piece tubular offset-mounted door handle
- 31" (787 mm) gusset-style legs with stainless steel cladding standard
- Adjustable bullet feet
- 3/4" NPT rear gas connection

STANDARD WARRANTY:

- One Year, Parts & Labor
- Lifetime Warranty on Door

AGENCY APPROVALS

- NSF Listed
- CSA Design Certified to ANSI Z83.11 * CSA 1.8



LEGEND™ Single Deck Gas Pizza Ovens

Item No. _____

Project _____

Quantity _____

Dimensions in brackets are millimeters

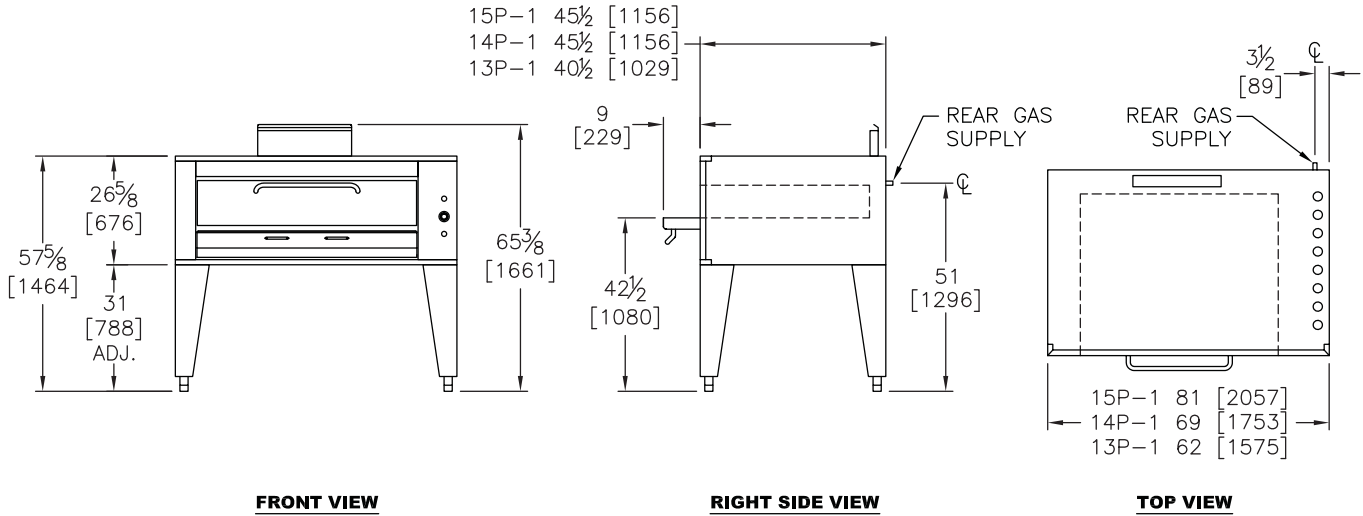

OPTIONS GUIDE:

Oven Interior:

- Fire brick baking hearth/deck

Installation Alternatives:

- Downdraft diverter [in lieu of flue deflector for direct flue connection, codes permitting]
- Stainless Steel Black Painted

Exterior Finish:

- Stainless steel back panel
Custom exterior decors. Consult Factory.
- Trim package
 Brass Copper

INSTALLATION REQUIREMENTS & SHIPPING INFORMATION

1. Ovens must be installed in accordance with local codes or in their absence with the National Fuel Gas Code: ANSI Z223.1; Natural Fuel Gas Code: CAN/CGA-B149.1 or Propane Installation Code: CAN/CGA-B149.2, as applicable. Compliance with codes is the responsibility of the Owner and Installer.
2. An adequate ventilation system is required. Refer to National Fire Protection Association Standard No. 96, "Standard for Ventilation and Fire Protection of Commercial Cooking Operations."
3. This appliance is intended for commercial use by professionally trained personnel. NOT intended for Residential Use.
4. **Specify installation elevation:** _____ if above 2000 feet (610 m).
5. **GAS INLET SIZE (All Models):** One 3/4" NPT gas connections provided at left-rear. One 3/4" NPT gas pressure regulators are provided and must be installed (by others) when unit is connected to gas supply.
6. The incoming gas line pressure into the regulator should be 8"-14" w.c. for natural gas, and 12"-14" w.c. for propane gas.

Minimum Clearances	Combustible Construction	Noncombustible Construction
From Back Wall	3" (76 mm)	3" (76 mm)
Left & Right Side	1" (25 mm)	0"
With 31" (787 mm) legs or Enclosed Base: Suitable for installation on combustible floors		

Specify Type of Gas:		<input type="checkbox"/> Natural		<input type="checkbox"/> Propane		Shipping Weight	Shipping Class	Cube (Crated) ft ³ /m ³
Models:	Burners	Manifold Pressure	BTU/hr* (kW)	Manifold Pressure	BTU/hr* (kW)			
13P-1	2	4.4" WC	80,000 (23.4)	10" WC	80,000 (23.4)	956 lbs (433 kg)	70	56/1.6
14P-1	3	3.5" WC	120,000 (35.2)	10" WC	120,000 (35.2)	1280 lbs (580 kg)	70	69/1.9
15P-1	4	3.1" WC	160,000 (46.9)	10" WC	160,000 (46.9)	1344 lbs (609 kg)	70	87/2.4

*Total BTU Input/firing rate

*Top fire brick and deck material ship in separate cartons

Due to continuous product improvements, specifications are subject to change without notice.



Pizzaovens.com

1.877.FOR.OVEN
367.6836

Since 1999



DO-1 [Rev. 01/10]