

NU-VU[®]

Bake **5** Pizzas Fast!

PMA-5/18 V-AIR[®]
Pizza Oven is small in size
and fast in baking.

This unit can bake five 18" pizzas at once!
Five different kinds of pizza can be baked at
the same time and quickly.

The **PMA-5/18** utilizes our **V-AIR[®]** technology
which ensures fast baking times with great
results. Other types of food products such as
sub rolls, pita bread and Italian food are baked
in this oven as well. The tabletop PMA-5/18
oven is small in size. It is high performance
and easy to use.



**V-AIR[®] Air flow system means no more turning
of pans, even baking with no hot spots
and energy efficient.**



Pizzaovens.com

1.877.FOR.OVEN
367.6836

Since 1999





PMA-5/18 V-Air® Tabletop Pizza Oven

STANDARD FEATURES:

- V-Air® technology
- Stainless steel construction
- Stainless steel hinges
- Flush mount lift off, no sag door
- Tempered glass door
- Silicone rubber gasket on door
- Flip down doors for each deck
- Set of 6" legs

OPTIONS:

- Cart with Pizza Panslides
- Cart with Panslides

CONSTRUCTION:

- Welded stainless steel utilizing 16 and 18 gauge
- Minimum of 2" insulation
- Control panel accessible through top of unit
- Timer panel accessible through front and side
- Heating elements accessible inside of cabinet and through top

CONTROLS:

- Solid state controls
- Indicator light for thermostat
- Microswitch fan motor cut-off
- Individual count down timer for each deck

DOOR SWING: • Oven: 24-1/2"

CLEARANCE:

- Allow four inches on each side and back of unit.

SERVICE CONNECTIONS:

- Unit is shipped from factory to be hard wired on site. Single phase uses four wire system. Three phase uses five wire system.
- 120/208 or 120/240 Volt single or three phase is standard. Please specify at time of order.
- Two 5,000 Watt heating elements are mounted in the oven sidewalls.

SHIPPING WEIGHT: • 325 Pounds, FOB Menominee, MI 49858

DIMENSIONS:

	Height	Width	Depth
Exterior	40-3/8"	28-7/8"	36"
Interior	18"	18-1/2"	28"

CAPACITY:

	18" Pizza Pans	Spacing
Oven	5	3"

Wide (32-5/8"including controls)

ELECTRICAL:

Amp Draw	120/208/1	120/208/3	120/240/1	120/240/3
L1	52	28	46	25
L2	48	48	42	42
L3	n/a	24	n/a	21

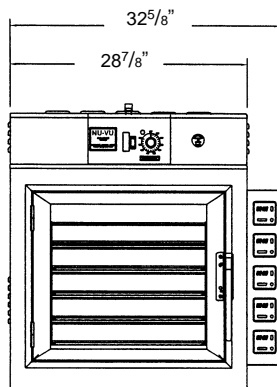

FRONT

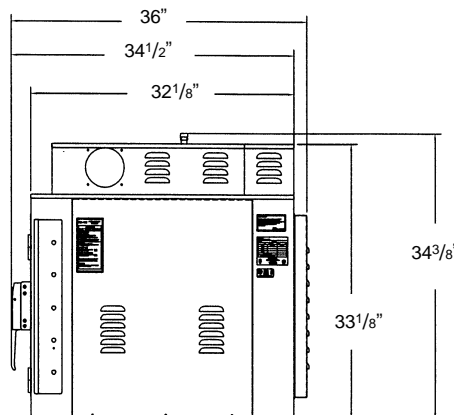

SIDE

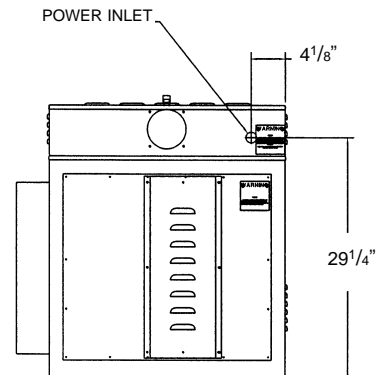

BACK



Pizzaovens.com

1.877.FOR.OVEN
367.6836

Since 1999