



DESIGNED FOR HIGH VOLUME APPLICATIONS

16 Gallons per Hour – 25 Quart Capacity

HIGH FROZEN PRODUCT VISIBILITY MEANS HIGH PROFITS!

The **SaniServ** model 108R Frozen Beverage Freezer provides owners and operators everything they are asking for: *Frozen beverage visibility merchandising* in a consistent and reliable machine with *remote refrigeration* and *remote auto fill!* The unit's extra large 8" faceplate design allows customers to view colorful frozen beverages being offered without the condensation and unreliable operation of traditional "bubble top" machines! The high frozen product visibility, along with increased production and reliability, results in increased sales and high profits! The 108R's remote refrigeration system is ideal for lowering costly indoor air conditioning operating costs by providing less heat build up while providing quieter operation!

SPACE SAVING

Small Footprint Design - SaniServ model 108R offers frozen product visibility in reliable space saving equipment and design! Owners and Operators can turn the countertop into a highly colorful profit center by providing the frozen beverages customers enjoy!

EASY CLEANING AND OPERATION

Fewer Parts = Simplified Cleaning – SaniServ equipment is designed and built with the fewer parts to be disassembled, cleaned and sanitized than any other machine in the industry.

HIGH RETURN ON INVESTMENT

Increased Profits – SaniServ machines combine affordable efficiency with consistent product quality and fast quiet operation to insure customer satisfaction with high profit frozen beverages.

QUALITY DESIGN

Durability – SaniServ machines are built to achieve long and dependable life through simplicity of design. Every machine is shipped standard with a stainless steel exterior, durable steel interior frame construction, heavy-duty components and consistency systems.

Model 108R

Countertop
Frozen Beverage Machine
Remote Fill & Remote Condenser



Made in USA

We reserve the right to change specifications and products design without notice. Such revisions do not entitle the buyer to corresponding changes, improvements, additions or replacements for previously purchased equipment

MODEL 108R

Counter Frozen Beverage Freezer w/Remote Condenser

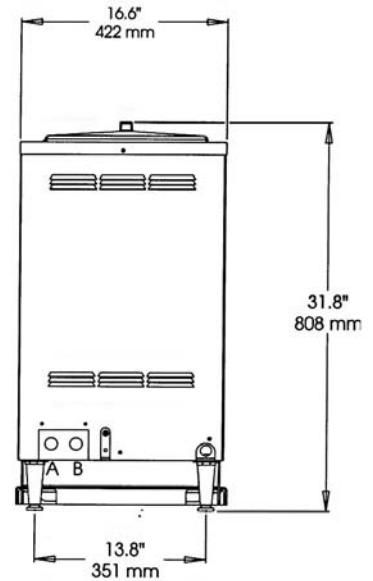
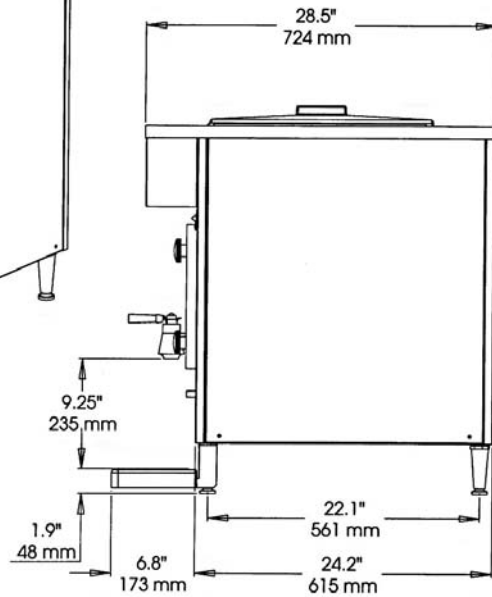
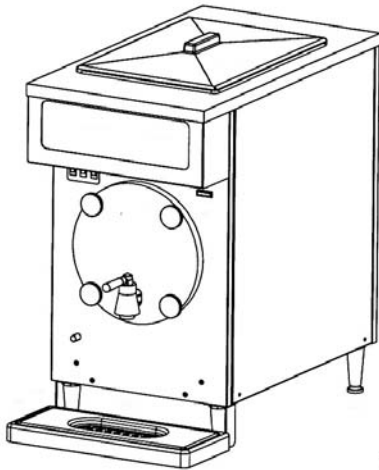

Minimum Wall Clearance
Both Sides and Back -
6 inches (152 mm)

A 5/8" SUCTION LINE QUICK DISCONNECT
B 3/8" LIQUID LINE QUICK DISCONNECT

ELECTRICAL				WIDTH	HEIGHT	DEPTH	WEIGHT	VOLUME
VOLTS	Hz	Ph.	Amps	INCHES (MM)	INCHES (MM)	INCHES (MM)	LBS. (Kg)	CU FT. (cu. m.)
115	60	1	15	16.6 (422)	31.8 (808)	28.5 (724)	150 (69)	
Shipping Specifications				22.5 (572)	36.5 (965)	36.5 (927)	185 (85)	18 (.51)

Specifications:

Cooling System:
Remote Required

Dasher Motor:
1/2 HP

Refrigerant Type:
R404A

Listings:
NSF

Features:

Evaporator and Mix Reservoir Capacity:
25 Quarts (23.6 liters)

Dasher:
Heavy-Duty Stainless Steel with low friction scraper blades.

Controls:
Automatic consistency controls for improved product consistency.

Solid-state Automatic Visual Mix Out Alert System

Warranty:

Parts 1 year
Evaporator 5 years

Options:

Tune Up Kit
Parts Tray
Drink Spinner
Machine Stand
Export Voltage
Wash Out Kit – 3/8" Flare Fitting
Remote Condenser*

* Requires a remote condensing unit (condenser & compressor) connected by two refrigeration lines.