



DESIGNED FOR MEDIUM VOLUME APPLICATIONS

8 Gallons per Hour – 20 Quart Capacity

HIGH CAPACITY WITH 110 VOLT CONVENIENCE!

The **SaniServ** model 707 Frozen Beverage Freezer is a customer favorite! Its sleek single barrel profile has the ability to offer many types of slush beverages! Choose from frozen margaritas and daiquiris to frozen fruit flavor drinks such as frozen lemonade and fruit smoothies. The 707 is a must have for the customer looking for an affordable way to offer all of their favorite beverages frozen!

SPACE SAVING

Small Footprint Design - SaniServ Save valuable floor space and turn the bar or countertop into a real profit center. By offering the finest quality of frozen drinks each time, every frozen beverage is consistent from the first to the last!

EASY CLEANING AND OPERATION

Fewer Parts = Simplified Cleaning – SaniServ equipment is designed and built with the fewer parts to be disassembled, cleaned and sanitized than any other machine in the industry. The state of the art solid-state **AccuFreeze** control insures product consistency, worry-free operation and customer satisfaction.

HIGH RETURN ON INVESTMENT

Increased Profits – SaniServ machines combine affordable efficiency with consistent product quality and fast quiet operation to insure customer satisfaction with high profit frozen beverages.

QUALITY DESIGN

Durability – SaniServ machines are built to achieve long and dependable life through simplicity of design. Every machine is shipped standard with a stainless steel exterior, durable steel interior frame construction, heavy-duty components and consistency systems.

Model 707

Countertop
Frozen Beverage Machine
With **AccuFreeze** Control



Made in USA

We reserve the right to change specifications and products design without notice. Such revisions do not entitle the buyer to corresponding changes, improvements, additions or replacements for previously purchased equipment

MODEL 707

Counter Model Frozen Beverage/Cocktail Freezer

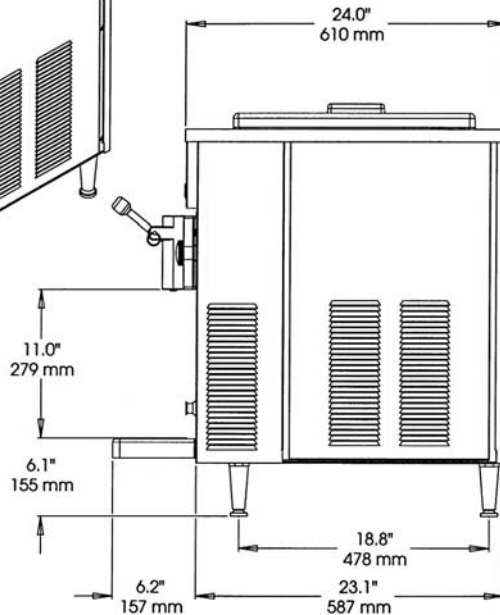
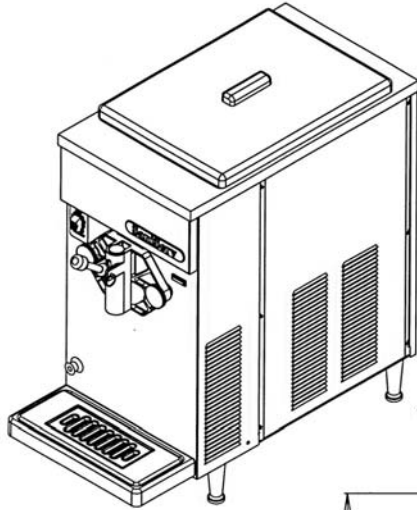

Minimum Wall Clearance
Both Sides and Back -
6 inches (152 mm)

ELECTRICAL				WIDTH	HEIGHT	DEPTH	WEIGHT	VOLUME
VOLTS	Hz	Ph.	Amps	INCHES (MM)	INCHES (MM)	INCHES (MM)	LBS. (Kg)	CU FT. (cu. m.)
115	60	1	15	14 (356)	31 (787)	24 (610)	159 (72)	
Shipping Specifications				22.5 (572)	33.5 (851)	34.5 (876)	176 (80)	18.1 (.51)

Specifications:

Cooling System:
Air Only

Dasher and Compressor Motors:

1/4 HP Dasher
1/2 HP Compressor

Refrigerant Type:

R404A

Listings:

UL, NSF

Features:

Evaporator and Mix Reservoir Capacity:
20 Quarts (18.9 liters)

Dasher:

Heavy-Duty Stainless Steel with low friction scraper blades.

Controls:

AccuFreeze solid-state control for accurate product consistency.

Solid State Audio/Visual Mix Out System with Compressor Lockout

Warranty:

Parts 1 year
Compressor 5 years
Evaporator 5 years

Options:

Tune Up Kit
Parts Tray
Drink Spinner
Syrup Rail
Counter Top Mounting Pad Machine Stand
Wash Out Kit – 3/8" Flare Fitting
Export Voltage