

THERMA-TEK

R A N G E C O R P .



Pizzaovens.com

Your Complete Source

for buying the right equipment



TMDS48-8-2
(Optional casters shown)

NOTE: Ranges supplied with casters must be installed with an approved restraining device.

OPTIONAL FEATURES

- * 6" (152.5 mm) swivel casters.
- * Gas flex hose w/ quick disconnect and restraining device.
- * Extra oven rack.
- * Range base convection oven available on 26 $\frac{1}{4}$ " (677 mm) full size oven.
- * 17" (432 mm) High Backguard.
No charge in lieu of high shelf.
- * 10" (254 mm) Low Profile Backguard.
No charge in lieu of high shelf.
- * Thicker griddle plates are optional.
- * Thermostat controlled griddles.
- * Hot tops 12" sections (305 mm).
- * Galvanized exterior sides, aluminized oven interior with porcelain oven bottom and door panel (TMDE model).
- * Stainless steel exterior with fully porcelainized oven interior (TMDU model).
- * CE-approved flame failure device available on most models.

GAS RESTAURANT RANGE 48"

GENERAL SPECIFICATIONS

Gas medium duty range 48" (1219 mm) wide with space-saver ovens accepting 18" x 26" (457 mm x 660 mm) sheet pans. Oven is heated by a heavy duty straight tube burner. Lift off cast iron open top burners. Individual top grates for each burner. Available 3/4 inch (19mm) thick griddle plate. Valve controlled or thermostatically controlled. Griddles are heated by a heavy duty "H" burner. Available with hot tops in 12" (305 mm) sections. Hot tops are heated by heavy duty "H" burners. Aluminized oven interior. Porcelain inner door panel and removable oven bottom. Fully stainless steel exterior. Single deck high shelf is standard. Also available with one full size oven and 12" (305 mm) storage.

STANDARD FEATURES

- * Fully stainless steel exterior including single deck high shelf.
- * 6" (152.5 mm) adjustable legs.
- * 5" (127 mm) stainless steel front rail.
- * Gas pressure regulator.
- * One year limited parts and labor warranty.

OVEN

- * Heavy gauge welded frame construction.
- * Aluminized oven interior. Porcelain inner door panel and removable oven bottom.
- * Space-saver oven dimensions 20 $\frac{1}{4}$ " wide, 27" deep, 14 $\frac{5}{16}$ " high (514 mm x 686 mm x 363.5 mm).
- * Full size oven dimensions 26 $\frac{1}{4}$ " wide, 27" deep, 14 $\frac{5}{16}$ " high (667 mm x 686 mm x 363.5 mm).
- * Removable chrome plated oven side racks.
- * One chrome plated oven rack.
- * Ribbed oven door for added strength.
- * Thermostat is adjustable from 150° F to 500° F (66° C to 260° C).
- * Heavy duty straight tube burner @ 27,000 BTU's (7.91 kW). 20" Space-saver oven.
- * Heavy duty straight tube burner @ 35,000 BTU's (10.25 kW). 26" full size oven.
- * Push button spark igniter for pilot.

OPEN TOP BURNERS

- * Cast iron lift off burners rated at 30,000 BTU's (8.79 kW).
- * Spill-proof pilot ignition system.
- * Individual cast iron top grates.
- * Controlled by a brass valve with infinite adjustment.

GRIDDLES

- * 3/4" (19 mm) thick polished steel plate.
- * 21 1/2" (546 mm) working depth.
- * Spatula width grease trough.
- * One heavy duty "H" burner per 12" (305 mm) section @ 20,000 BTU's (5.86 kW).
- * Each 12" (305 mm) section is controlled by a valve or a thermostat.
- * Manual control is standard.
- * Thermostat control is optional.
- * Large capacity grease container with integral lid.

HOT TOP

- * Heavy cast hot top available in 12" (305 mm) sections.
- * Heavy duty "H" burner per 12" (305 mm) section @ 20,000 BTU's (5.86 kW).
- * Hot top surface is level with open top burners for easy movement of pots.

RADIANT CHAR BROILER

- * Cast iron H-type burner per 12" section; at 30,000 BTU/hr (8.79kW).
- * Heavy cast-iron radiants with multiple heat sinks.
- * Heavy-duty cast-iron grates for maximum heat retention.
- * Single piece precision brass valves with infinite heat control.

CHAR-ROCK BROILERS

- * Cast iron H-type burner per 12" section; at 30,000 BTU/hr (8.79kW).
- * High quality lava rocks on cast iron supports provide maximum heat.
- * Burners protected by heat shield to prevent blockage of ports and pilots.
- * Heavy-duty cast-iron grates for maximum heat retention.
- * Single piece precision brass valves with infinite heat control.

THERMA-TEK

RANGE CORP.

Therma-Tek Range Corp.
115 Rotary Drive, Valmont Industrial Park
West Hazleton, PA 18202

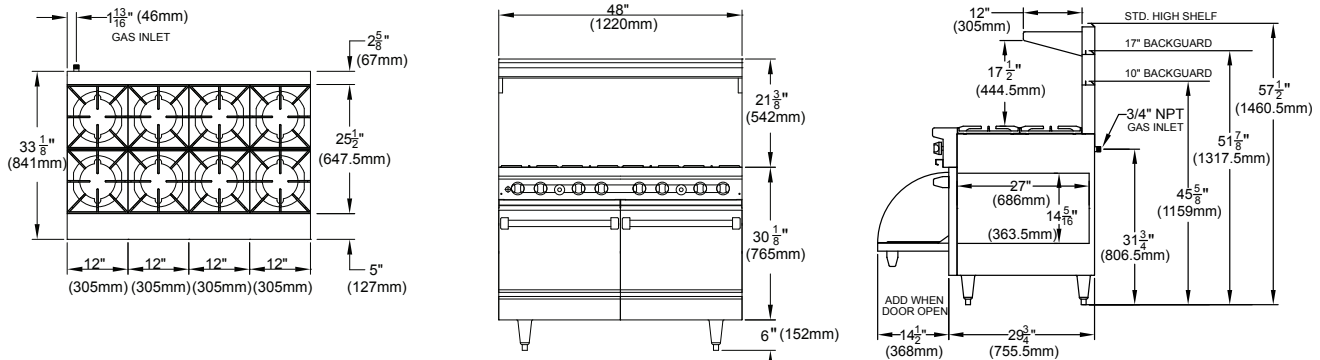

Crated Dimensions			
Width 55" (1397mm)	Depth 45" (1143mm)	Height 41 1/4" (1048mm)	Cubic Feet 59

Entry Clearance	
Crated 46" (1168mm)	Uncrated 34" (864mm)



Uncrated Exterior Dimensions			Oven Interior Dimensions				Installation Clearances From Combustibles		
Height (w/highshelf) 57 1/2" (1461mm)	Width 48" (1219mm)	Depth 33 3/8" (841mm)	Height 14 5/16" (364mm)	Width Space-saver 20 1/4" (514mm)	Width Full size 26 1/4" (667mm)	Depth 27" (686mm)	Open Burner	Sides 12" (305mm)	Rear 6" (152.5mm)
							Griddle, Hot Top, Char Broiler	6" (152.5mm)	6" (152.5mm)

Input Rating Per Burner Type (Natural and Propane Gas)										Operating Manifold Gas Pressure					
Open		Griddle		Char Broiler		Hot Top		Space-saver Oven		Full size Oven		Natural		Propane	
BTU	kW	BTU	kW	BTU	kW	BTU	kW	BTU	kW	BTU	kW	"WC	mbar	"WC	mbar
30,000	8.79	20,000	5.86	30,000	8.79	20,000	5.86	27,000	7.91	35,000	10.25	5	12.45	10	24.9

Model Number	Description	Gross Weight		
		Total BTU/Hr	Lbs.	Kg
TMDS48-8-2	Eight open burners, two 20" space-saver ovens	294,000	740	336
TMDS48-8-0-1	Eight open burners, one storage base, one 20" space-saver oven	267,000	650	295
TMDS48-8-0	Eight open burners, two storage bases	240,000	590	268
TMDS48-8-126	Eight open burners, one 26" full size oven, one 12" storage base	275,000	660	300
TMDS48-12G-6-2	12" griddle, six open burners, two 20" space-saver ovens	254,000	760	345
TMDS48-12G-6-0-1	12" griddle, six open burners, one storage base, one 20" space-saver oven	227,000	720	327
TMDS48-12G-6-0	12" griddle, six open burners, two storage bases	200,000	640	291
TMDS48-12G-6-126	12" griddle, six open burners, one 26" full size oven, one 12" storage base	235,000	710	323
TMDS48-24G-4-2	24" griddle, four open burners, two 20" space-saver ovens	214,000	810	368
TMDS48-24G-4-0-1	24" griddle, four open burners, one storage base, one 20" space-saver oven	187,000	750	341
TMDS48-24G-4-0	24" griddle, four open burners, two storage bases	160,000	690	314
TMDS48-24G-4-126	24" griddle, four open burners, one 26" full size oven, one 12" storage base	195,000	760	345
TMDS48-36G-2-2	36" griddle, two open burners, two 20" space-saver ovens	174,000	850	386
TMDS48-36G-2-0-1	36" griddle, two open burners, one storage base, one 20" space-saver oven	147,000	790	359
TMDS48-36G-2-0	36" griddle, two open burners, two storage bases	120,000	730	332
TMDS48-36G-2-126	36" griddle, two open burners, one 26" full size oven, one 12" storage base	155,000	800	364
TMDS48-48G-2	48" griddle, two 20" space-saver ovens	134,000	870	395
TMDS48-48G-0-1	48" griddle, one storage base, one 20" space-saver oven	107,000	810	368
TMDS48-48G-0	48" griddle, two storage bases	80,000	750	341
TMDS48-48G-126	48" griddle, one 26" full size oven, one 12" storage base	115,000	820	373

Installation Notes

This product is NOT approved for residential use. Please advise us of installation over 2000ft. (610m) altitude. Installation clearance reduction applies only where local codes permit. All Therma-Tek products are covered by a one year limited parts and labor warranty. A detailed warranty is included with the appliance or is available upon request. Installation and/or operation by other than manufacturer's recommendations may void warranty.

NOTE: Add suffix "N" for natural gas, and "L" for propane. Because of continuing product improvement, these specifications are subject to change without notice. Printed July 2008 Printed in the USA