

THERMA-TEK

R A N G E C O R P .



Pizzaovens.com

Your Complete Source

for buying the right equipment



TMDS60-10-2

(Optional casters shown)

NOTE: Ranges supplied with casters must be installed with an approved restraining device.

OPTIONAL FEATURES

- * 6" (152.5 mm) swivel casters.
- * Gas flex hose w/ quick disconnect and restraining device.
- * Extra oven rack.
- * Range base convection oven.
- * 17" (432 mm) High Backguard.
No charge in lieu of high shelf.
- * 10" (254 mm) Low Profile Backguard.
No charge in lieu of high shelf.
- * Thicker griddle plates are optional.
- * Thermostat controlled griddles.
- * Hot tops 12" sections (305 mm).
- * Galvanized exterior sides, aluminized oven interior with porcelain oven bottom and door panel (TMDE model).
- * Stainless steel exterior with fully porcelainized oven interior (TMDU model).
- * CE-approved flame failure device available on most models.

GAS RESTAURANT RANGE 60"

GENERAL SPECIFICATIONS

Gas medium duty range 60" (1524 mm) wide with full size oven accepting 18" x 26" (457 mm x 660 mm) sheet pans in either direction. Oven is heated by a heavy duty straight tube burner. Lift off cast iron open top burners. Individual top grates for each burner. Available 3/4 inch (19mm) thick griddle plate. Valve controlled or thermostatically controlled. Griddles are heated by a heavy duty "H" burner. Available with hot tops in 12" (305 mm) sections. Hot tops are heated by heavy duty "H" burners. Aluminized oven interior. Porcelain inner door panel and removable oven bottom. Fully stainless steel exterior. Single deck high shelf is standard.

STANDARD FEATURES

- * Fully stainless steel exterior including single deck high shelf.
- * 6" (152.5 mm) adjustable legs.
- * 5" (127 mm) stainless steel front rail.
- * Gas pressure regulator.
- * One year limited parts and labor warranty.

OVEN

- * Heavy gauge welded frame construction.
- * Aluminized oven interior. Porcelain inner door panel and removable oven bottom.
- * Oven dimensions 26 3/4" wide, 27" deep, 14 3/16" high (667 mm x 686 mm x 363.5 mm).
- * Removable chrome plated oven side racks.
- * One chrome plated oven rack.
- * Ribbed oven door for added strength.
- * Thermostat is adjustable from 150° F to 500° F (66° C to 260° C).
- * Heavy duty straight tube burner @ 35,000 BTU's (10.25 kW).
- * Push button spark igniter for pilot.

OPEN TOP BURNERS

- * Cast iron lift off burners rated at 30,000 BTU's (8.79 kW).
- * Spill-proof pilot ignition system.
- * Individual cast iron top grates.
- * Controlled by a brass valve with infinite adjustment.

GRIDDLES

- * 3/4" (19 mm) thick polished steel plate.
- * 21 1/2" (546 mm) working depth.
- * Spatula width grease trough.
- * One heavy duty "H" burner per 12" (305 mm) section @ 20,000 BTU's (5.86 kW).
- * Each 12" (305 mm) section is controlled by a valve or a thermostat.
- * Manual control is standard.
- * Thermostat control is optional.
- * Large capacity grease container with integral lid.

HOT TOP

- * Heavy cast hot top available in 12" (305 mm) sections.
- * Heavy duty "H" burner per 12" (305 mm) section @ 20,000 BTU's (5.86 kW).
- * Hot top surface is level with open top burners for easy movement of pots.

RADIANT CHAR BROILER

- * Cast iron H-type burner per 12" section; at 30,000 BTU/hr (8.79kW).
- * Heavy cast-iron radiants with multiple heat sinks.
- * Heavy-duty cast-iron grates for maximum heat retention.
- * Single piece precision brass valves with infinite heat control.

CHAR-ROCK BROILERS

- * Cast iron H-type burner per 12" section; at 30,000 BTU/hr (8.79kW).
- * High quality lava rocks on cast iron supports provide maximum heat.
- * Burners protected by heat shield to prevent blockage of ports and pilots.
- * Heavy-duty cast-iron grates for maximum heat retention.
- * Single piece precision brass valves with infinite heat control.

THERMA-TEK

R A N G E C O R P .

Therma-Tek Range Corp.
 115 Rotary Drive, Valmont Industrial Park
 West Hazleton, PA 18202

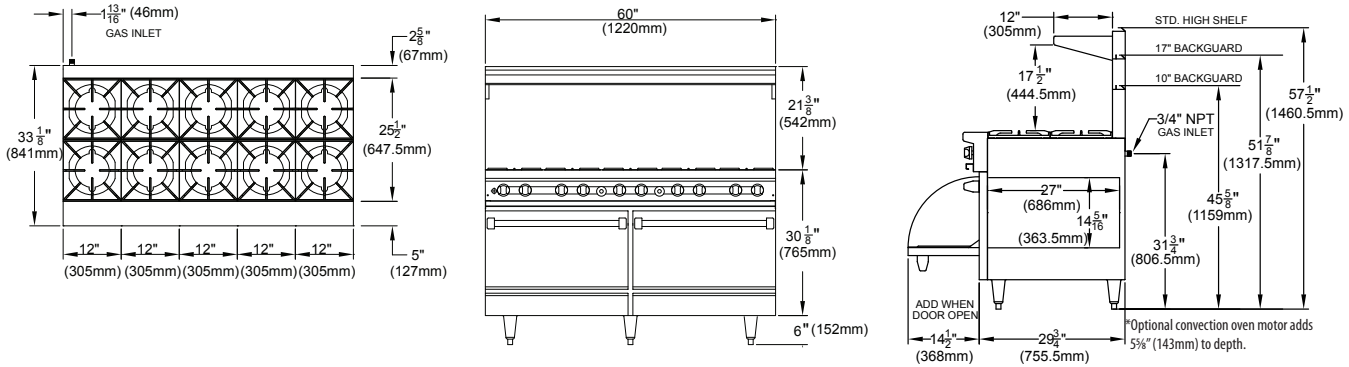

Crated Dimensions			
Width 67" (1702mm)	Depth 45" (1143mm)	Height 51" (1295mm)	Cubic Feet 72

Entry Clearance	
Crated 46" (1168mm)	Uncrated 34" (864mm)



Uncrated Exterior Dimensions			Oven Interior Dimensions			Installation Clearances From Combustibles		
Height (w/highshelf) 57 1/2" (1461mm)	Width 60" (1524mm)	Depth* 33 7/8" (841mm)	Height 14 5/16" (364mm)	Width 26 1/4" (667mm)	Depth 27" (686mm)	Open Burner	Sides 12" (305mm)	Rear 6" (152.5mm)
						Griddle, Hot Top, Char Broiler	6" (152.5mm)	6" (152.5mm)

Input Rating Per Burner Type (Natural and Propane Gas)								Operating Manifold Gas Pressure					
Open		Griddle		Char Broiler		Hot Top		Oven		Natural		Propane	
BTU	kW	BTU	kW	BTU	kW	BTU	kW	BTU	kW	"WC	mbar	"WC	mbar
30,000	8.79	20,000	5.86	30,000	8.79	20,000	5.86	35,000	10.25	5	12.45	10	24.9

Model Number	Description	Total BTU/Hr	Gross Weight	
			Lbs.	Kg
TMDS60-10-2	Ten open burners, two ovens	370,000	980	445
TMDS60-10-0-1	Ten open burners, one storage base, one oven	335,000	910	414
TMDS60-10-0	Ten open burners, two storage bases	300,000	840	382
TMDS60-12G-8-2	12" griddle, eight open burners, two ovens	330,000	1020	464
TMDS60-12G-8-0-1	12" griddle, eight open burners, one storage base, one oven	295,000	950	432
TMDS60-12G-8-0	12" griddle, eight open burners, two storage bases	260,000	880	400
TMDS60-24G-6-2	24" griddle, six open burners, two ovens	290,000	1060	488
TMDS60-24G-6-0-1	24" griddle, six open burners, one storage base, one oven	255,000	990	450
TMDS60-24G-6-0	24" griddle, six open burners, two storage bases	220,000	920	418
TMDS60-36G-4-2	36" griddle, four open burners, two ovens	250,000	1085	493
TMDS60-36G-4-0-1	36" griddle, four open burners, one storage base, one oven	215,000	1015	461
TMDS60-36G-4-0	36" griddle, four open burners, two storage bases	180,000	945	430
TMDS60-48G-2-2	48" griddle, two open burners, two ovens	210,000	1095	498
TMDS60-48G-2-0-1	48" griddle, two open burners, one storage base, one oven	175,000	1025	466
TMDS60-48G-2-0	48" griddle, two open burners, two storage bases	140,000	955	434
TMDS60-60G-2	60" griddle, two ovens	170,000	1115	507
TMDS60-60G-0-1	60" griddle, one storage base, one oven	135,000	1045	475
TMDS60-60G-0	60" griddle, two storage bases	100,000	975	443

Installation Notes

This product is NOT approved for residential use. Please advise us of installation over 2000ft. (610m) altitude. Installation clearance reduction applies only where local codes permit. All Therma-Tek products are covered by a one year limited parts and labor warranty. A detailed warranty is included with the appliance or is available upon request. Installation and/or operation by other than manufacturer's recommendations may void warranty.

NOTE: Add suffix "N" for natural gas, and "L" for propane. Because of continuing product improvement, these specifications are subject to change without notice. Printed July 2008 Printed in the USA