

**THERMA-TEK**  
R A N G E C O R P .



TSM36

## COMMERCIAL GAS INFRA-RED SALAMANDER BROILER

### STANDARD FEATURES

- \* Fully stainless steel exterior.
- \* 4" (101.5 mm) adjustable legs (counter model).
- \* Gas pressure regulator.
- \* Two steel wire mesh infra-red burners.
- \* 20,000 BTUs (5.86 kW per burner) .
- \* Each burner is individually controlled.
- \* Ignition by standing pilot for each burner.
- \* 365 sq. inches of rack space.
- \* Chrome plated rack.
- \* Rack has four adjustable positions.
- \* Rack carriage assembly rolls out for ease of loading and unloading.
- \* Heavy duty springs counter balance the assembly.
- \* Full width grease deflector channels hot drippings to a large capacity drip pan.
- \* Drip pan and rack carriage assembly are easily removed for cleaning.
- \* One year limited parts and labor warranty.
- \* Range mount, wall mount and counter mount models available.

### OPTIONAL FEATURES

- \* ICPK (interconnecting piping) between salamander and range.
- \* Stainless steel bottom.
- \* RMK (Range Mount Kit).
- \* CMK (Counter Mount Kit).
- \* WMK (Wall Mount Kit).
- \* Additional rack.
- \* CE-approved flame failure device available on most models.



Therma-Tek Range Corp.  
115 Rotary Drive, Valmont Industrial Park  
West Hazleton, PA 18202

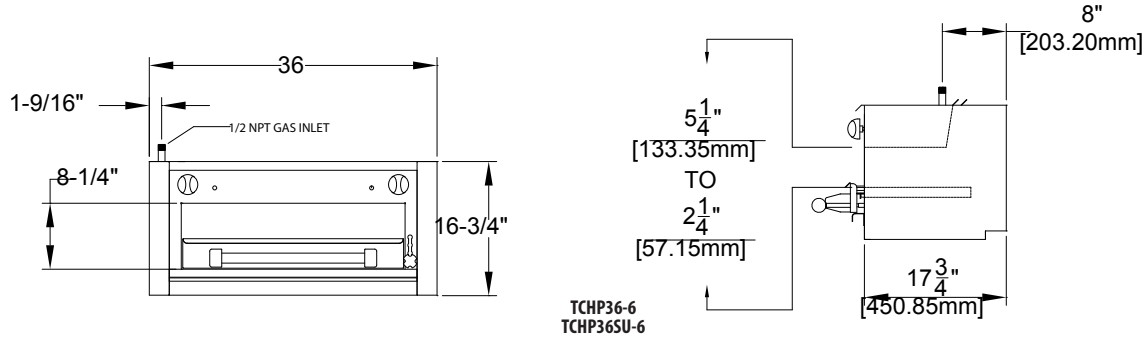

**GAS REQUIREMENTS**

Operating Manifold Gas Pressure		Manifold Connection		Input Rating per Burner	
Natural	Propane	1/2" NPT		Total BTU/Hr	kW
"WC	mbar	"WC	mbar		
5	12.45	10	24.9	20,000	5.86

Model Number	Description	Total gas consumption per model		Gross Weight	
		Total BTU/Hr	kW	Lbs.	Kg
TSM36	Two infra-red burners	40,000	11.72	215	97.5

NOTE: Add suffix "N" for natural gas, and "L" for propane.

CLEARANCES	Sides	Back
Non Combustible	0"	0"
Combustible	6" (152.4 mm)	6" (152.4 mm)

**Installation Notes**

This product is NOT approved for residential use.  
Please advise us of installation over 2000ft. (610m) altitude.  
Installation clearance reduction applies only where local codes permit.  
All Therma-Tek products are covered by a one year limited parts and labor warranty.  
A detailed warranty is included with the appliance or is available upon request.  
Installation and/or operation by other than manufacturer's recommendations may void warranty.  
*Because of continuing product improvement, these specifications are subject to change without notice.*



Printed July 2008  
Printed in the USA