



**TRUE FOOD SERVICE
EQUIPMENT, INC.**



Pizzaovens.com

1.877.FOR.OVEN
367.6836

Since 1999

Project Name: _____

Location: _____

Item #: _____ Qty: _____

Model #: _____

A/A #

SIS #

Model:

TSSU-72-18

Food Prep Table:

Solid Door Sandwich/Salad Unit

TSSU-72-18



- ▶ True's salad/sandwich units are designed with enduring quality that protects your long term investment.
- ▶ Oversized, environmentally friendly (134A) patented, forced-air refrigeration system holds 33°F to 41°F (.5°C to 5°C).
- ▶ Complies with and listed under ANSI/NSF-7-1997-6.3.
- ▶ All stainless steel front, top and cabinet ends. Matching aluminum finished back.
- ▶ Stainless steel, patented, foam insulated lid and hood keep pan temperatures colder, lock in freshness and minimize condensation. Removable for easy cleaning.
- ▶ 11³/₄" (299 mm) deep, 1/2" (13 mm) thick, full length removable cutting board included. Sanitary, high density, NSF approved white polyethylene provides tough preparation surface.
- ▶ Heavy duty PVC coated wire shelves.
- ▶ Foamed-in-place, high density polyurethane insulation (CFC free).

ROUGH-IN DATA

Specifications subject to change without notice. Chart dimensions rounded up to the nearest 1/8" (millimeters rounded up to next whole number).

Model	Doors	Capacity (Cu. Ft.) (liters)	Shelves	Pans (top)	Cabinet Dimensions (inches) (mm)			HP	Voltage	Amps	NEMA Config.	Cord Length (total ft.) (total m)	Crated Weight (lbs.) (kg)
					L	D [†]	H*						
TSSU-72-18	3	19.0 538	6	18	72 ³ / ₈ 1839	30 ¹ / ₈ 766	36 ³ / ₄ 934	1/2 1/2	115/60/1 230-240/50/1	10.3 6.7	5-15P ▲	7 2.13	405 184

† Depth does not include 1" (26 mm) for rear bumpers.

* Height does not include 6¹/₄" (159 mm) for castors or 6" (153 mm) for optional legs.

▲ Plug type varies by country.



3/08

Printed in U.S.A.

APPROVALS:

AVAILABLE AT:

Model:
TSSU-72-18

Food Prep Table:
Solid Door Sandwich/Salad Unit



STANDARD FEATURES

DESIGN

- True's commitment to using the highest quality materials and oversized refrigeration systems provides the user with colder product temperatures, lower utility costs, exceptional food safety and the best value in today's food service marketplace.

REFRIGERATION SYSTEM

- Factory engineered, self-contained, capillary tube system using environmentally friendly (CFC free) 134A refrigerant.
- Oversized, factory balanced refrigeration system with guided airflow to provide uniform temperature in food pans and cabinet interior.
- Patented forced-air design holds 33°F to 41°F (.5°C to 5°C) product temperature in food pans and cabinet interior. Complies with and listed under ANSI/NSF-7-1997-6.3.
- Sealed, cast iron, self-lubricating evaporator fan motor(s) and larger fan blades give True sandwich/salad units a more efficient low velocity, high volume airflow design.
- Condensing unit access in back of cabinet, slides out for easy maintenance.

CABINET CONSTRUCTION

- Exterior - stainless steel front, top and cabinet ends. Matching aluminum finished back.
- Interior - attractive, NSF approved, white aluminum liner. 300 series stainless floor with coved corners.
- Insulation - entire cabinet structure and solid doors are foamed-in-place using high density, CFC free, polyurethane insulation.
- 5" (127 mm) diameter stem castors - locks provided on front set. 36" (915 mm) work surface height.

DOORS

- Stainless steel exterior with white aluminum liner to match cabinet interior.
- Each door fitted with 12" (305 mm) long recessed handle that is foamed-in-place with a sheet metal interlock to ensure permanent attachment.

- Positive seal self-closing doors with 90° stay open feature. Doors swing within cabinet dimensions.
- Magnetic door gaskets of one piece construction, removable without tools for ease of cleaning.

SHELVING

- Six (6) adjustable, heavy duty PVC coated wire shelves. Two (2) right and two (2) left door shelf dimensions are 21⁹/₁₆" L x 16" D (548 mm x 407 mm). Two (2) center door shelf dimensions are 23¹/₂" L x 16" D (597 mm x 407 mm). Four (4) chrome plated shelf clips included per shelf.
- Shelf support pilasters made of same material as cabinet interior; shelves are adjustable on 1/2" (13 mm) increments.

MODEL FEATURES

- Evaporator is epoxy coated to eliminate the potential of corrosion.
- 11³/₄" (299 mm) deep, 1/2" (13 mm) thick, full length removable cutting board. Sanitary, high-density, NSF approved white polyethylene provides tough preparation surface.
- Stainless steel, patented, foam insulated lid and hood keeps pan temperatures colder, locks in freshness and minimizes condensation. Removable for easy cleaning.
- NSF-7 compliant for open food product.

PAN CAPACITY

- Comes standard with 18 (1/6 size) 6⁷/₈" L x 6¹/₄" W x 4" D (175 mm x 159 mm x 102 mm) clear polycarbonate, NSF approved, food pans in countertop prep area. Also accommodates 6" (153 mm) and 8" (204 mm) deep food pans (supplied by others).
- Countertop pan opening designed to fit varying size pan configurations with available pan divider bars. Varying size pans supplied by others.

ELECTRICAL

- Unit completely pre-wired at factory and ready for final connection to a 115/60/1 phase - 15 amp dedicated outlet. Cord and plug set included.



115/60/1
NEMA-5-15R

OPTIONAL FEATURES/ACCESSORIES

Upcharge and lead times may apply.

- 230 - 240V / 50 Hz.
- 6" (153 mm) standard legs.
- 6" (153 mm) seismic/flanged legs.
- 2¹/₂" (64 mm) diameter castors.
- Additional shelves.
- Sandwich/salad service shelf.
- Single overshef.
- Double overshef.
- Flat lid.
- Sneeze-guard.
- 19" (483 mm) deep, 1/2" (13 mm) thick, white polyethylene cutting board. Requires "L" brackets.
- 19" (483 mm) deep, 3/4" (20 mm) thick, white polyethylene cutting board. Requires "L" brackets.
- 11³/₄" (299 mm) deep, 1/2" (13 mm) thick, composite cutting board. Requires "L" brackets.
- 19" (483 mm) deep, 1/2" (13 mm) thick, composite cutting board. Requires "L" brackets.
- Crumb catcher. Requires crumb catcher cutting board for proper installation.
- Pan dividers.
- Exterior rectangular digital temperature display (factory installed).
- ADA compliant model with 34" (864 mm) work surface height.
- Remote cabinets (condensing unit supplied by others; system comes standard with 404A expansion valve and requires R404A refrigerant). Consult factory technical service department for BTU information.

PLAN VIEW

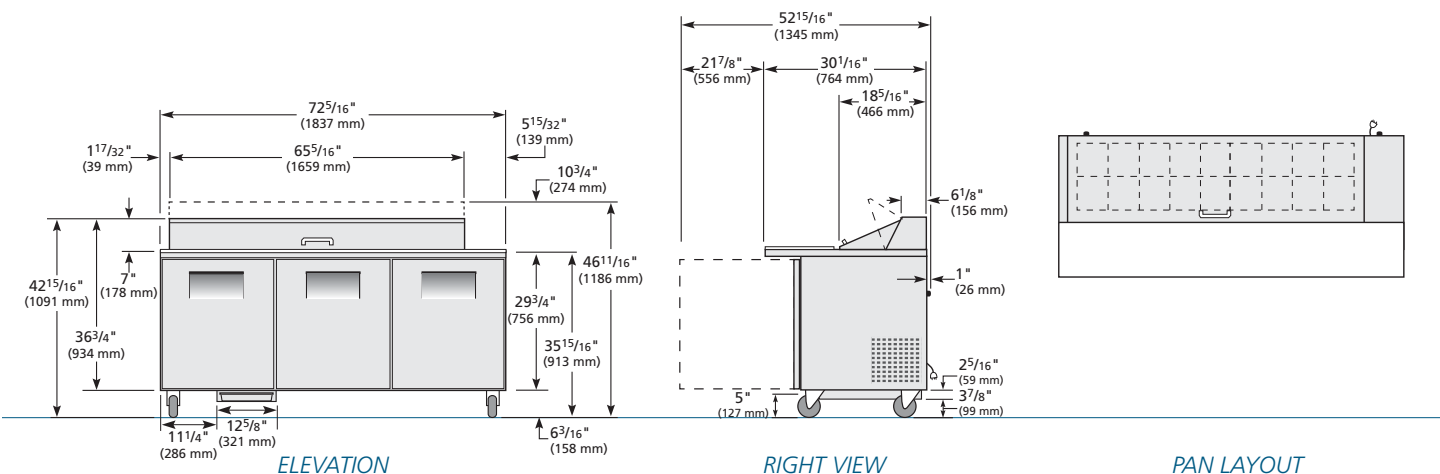

WARRANTY
One year warranty on all parts and labor and an additional 4 year warranty on compressor. (U.S.A. only)

METRIC DIMENSIONS ROUNDED UP TO THE NEAREST WHOLE MILLIMETER
SPECIFICATIONS SUBJECT TO CHANGE WITHOUT NOTICE

	Model	Elevation	Right	Plan	3D
	TSSU-72-18	TFNY09E	TFNY29S	TFNY09P	TFNY093