



**TRUE FOOD SERVICE
EQUIPMENT, INC.**



Pizzaovens.com

1.877.FOR.OVEN
367.6836

Since 1999

Project Name: _____

Location: _____

Item #: _____ Qty: _____

Model #: _____

A/A #

SIS #

Model:
TR1HPT-1S-1S

TR Specification Series:
Pass-Thru Solid Door Heated Cabinet



TR1HPT-1S-1S

- ▶ Provides cabinet holding temperature of 80°F to 180°F (26.6°C to 82.2°C).
- ▶ Equipped with low-velocity fans to assure even temperature distribution throughout the cabinet. Fans are controlled by exterior on/off switch.
- ▶ Two (2) stainless steel (for corrosion resistance), finned tube heating elements (1000 watts each) for uniform generation of electric heat. Cabinet comes with a total of 2000 watts.
- ▶ 300 series stainless steel exterior and interior. The very finest stainless with higher tensile strength for fewer dents and scratches.
- ▶ Equipped with one (1) interior kit option per full section, factory installed. Four (4) different interior kits available.
- ▶ Positive seal self-closing door with 120° stay open feature. Lifetime guaranteed door hinges and torsion type closure system.
- ▶ Entire cabinet structure and solid doors are foamed-in-place using high density, CFC free, polyurethane insulation.

ROUGH-IN DATA

Specifications subject to change without notice.

Chart dimensions rounded up to the nearest 1/8" (millimeters rounded up to next whole number).

Model	Doors	Capacity (Cu. Ft.) (liters)	Cabinet Dimensions (inches) (mm)			Watts	Voltage	NEMA Config.	Cord Length (total ft.) (total m)	Crated Weight (lbs.) (kg)
			L	D†	H*					
TR1HPT-1S-1S	2	31 878	29 737	37 1/4 947	78 1/4 1988	2000	115/208-240/60/1	14-20P	9 2.74	400 182

† Depth does not include 1 1/8" (29 mm) for system mechanical components

* Height does not include 6 1/8" (156 mm) for legs, 5" (127 mm) for optional castors and 1" (26 mm) for system mechanical components.

Requires 115/208 -240/60 Hz, single phase, 3 pole, 4 wire circuit.



APPROVALS:

AVAILABLE AT:

Model:
TR1HPT-1S-1S

TR Specification Series:
Pass-Thru Solid Door Heated Cabinet



STANDARD FEATURES

DESIGN

- True's solid door pass-thru heated cabinets are designed with enduring quality that protects your long term investment.

HEATER SYSTEM

- Cabinet is designed to provide holding temperatures of 80°F to 180°F (26.6°C to 82.2°C). Heating system controlled by exterior on/off switch and temperature control dial.
- Two (2) stainless steel (for corrosion resistance), finned tube heating elements (1000 watts each) for uniform generation of electric heat. Cabinet comes with a total of 2000 watts.
- Equipped with low-velocity fans to assure even temperature distribution throughout the cabinet. Fans are controlled by exterior on/off switch.
- Manually controlled vent located on top of the cabinet for positive humidity control.
- 12" x 20" (305 mm x 508 mm) pan for water included, if additional humidity required.

CABINET CONSTRUCTION

- Exterior - 300 series stainless steel doors, front, sides, back and bottom.
- Interior - 300 series stainless steel liner and floor.
- Insulation - entire cabinet structure and solid doors are foamed-in-place using high density, CFC free, polyurethane insulation.
- Welded, heavy duty galvanized frame rail dipped in rust inhibiting enamel paint for corrosion protection inside and out.
- Frame rail fitted with 6" (153 mm) stainless steel legs.

DOORS

- Front and rear doors are 300 series stainless steel exterior and liner. Doors open within cabinet dimension.
- Door locks standard.

- Lifetime guaranteed recessed door handles. Each door fitted with 12" (305 mm) long recessed handle that is foamed-in-place with a sheet metal interlock to ensure permanent attachment.
- Positive seal self-closing door with 120° stay open feature. Lifetime guaranteed door hinges and torsion type closure system.
- Magnetic door gaskets of one piece construction, removable without tools for ease of cleaning.

SHELVING

- One (1) factory installed, interior kit option. Four (4) different interior kits available (see kit options). Pilasters and tray slides are factory installed at no charge.

LIGHTING

- Incandescent interior lighting. Lights activated by exterior on/off switch; safety shielded

MODEL FEATURES

- Exterior, color coded, temperature display; accurate direct reading of internal cabinet temperature.
- Designed to hold warm baked or cooked food. Cabinet is not designed to heat ambient or cold product.
- NSF-4 compliant for open food product.

ELECTRICAL

- True requires a sole use circuit be dedicated for the unit.
- Unit completely pre-wired at factory and ready for final connection to a 115/208-240/60 Hz. single phase, 20 amp dedicated outlet. Cord and plug set included.



115/208-240/1
NEMA-14-20R

OPTIONAL FEATURES/ACCESSORIES

Upcharge and lead times may apply.

- 6" (153 mm) Seismic/flanged legs.
- 4" (102 mm) diameter swivel castors.
- Stainless steel rail skirt for use with legs (field installed).
- Metal door handles (factory installed).
- Electronic temperature control (factory installed).
- Correctional facilities options.
- Curb mountable units.

KIT OPTIONS

- Kit #1: Nine (9) sets of #1 type tray slides and pilasters (factory installed), bottom support of one (1) 18" L x 26" D (458 mm x 661 mm) pan or two (2) 14" L x 18" D (356 mm x 458 mm) pans.
- Kit #2: One (1) set half-section #2 steel rod tray slides and pilasters (factory installed), rim support of one (1) 18" L x 26" D (458 mm x 661 mm) pan.
- Kit #3: Six (6) sets of universal type tray slides and pilasters (factory installed), bottom support of one (1) 18" L x 26" D (458 mm x 661 mm) pan, two (2) 14" L x 18" D (356 mm x 458 mm) pans or two (2) 12" L x 20" D (305 mm x 508 mm) pans.
- Kit #4: Three (3) chrome shelves 25" L x 28¹³/₁₆" D (635 mm x 732 mm). Four (4) shelf clips included per shelf and wall mounted pilasters (factory installed). Shelves adjustable on 6" (153 mm) increments.
- Additional kit option components available individually.
- Stainless steel (electro polished) shelves to be used with Kit Option #4.

PLAN VIEW

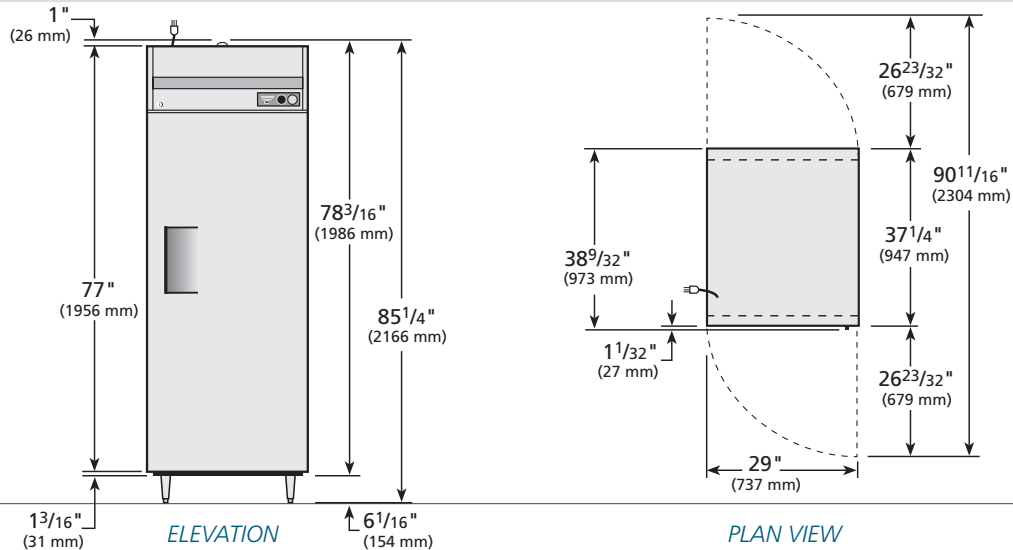

WARRANTY

One year warranty on all parts & labor (U.S.A. only)

METRIC DIMENSIONS ROUNDED UP TO THE NEAREST WHOLE MILLIMETER
SPECIFICATIONS SUBJECT TO CHANGE WITHOUT NOTICE



Model	Elevation	Right	Plan	3D
TR1HPT-1S-1S	TFQY179E	TFQY181S	TFQY181P	TFQY1813

TRUE FOOD SERVICE EQUIPMENT